



PMCprotego D.01 ... D.24

PILZ
THE SPIRIT OF SAFETY

► Servo amplifiers

This document is the original document.

All rights to this documentation are reserved by Pilz GmbH & Co. KG. Copies may be made for the user's internal purposes. Suggestions and comments for improving this documentation will be gratefully received.

Source code from third-party manufacturers or open source software has been used for some components. The relevant licence information is available on the Internet on the Pilz homepage.

Pilz®, PIT®, PMI®, PNOZ®, Primo®, PSEN®, PSS®, PVIS®, SafetyBUS p®, SafetyEYE®, SafetyNET p®, the spirit of safety® are registered and protected trademarks of Pilz GmbH & Co. KG in some countries.



SD means Secure Digital

Section 1	Introduction	8
	1.1	Validity of documentation 8
	1.1.1	Retaining the documentation 8
	1.2	Definition of symbols 8
Section 2	Overview	10
	2.1	Unit structure 10
	2.1.1	Unit features 10
	2.1.1.1	Power element 10
	2.1.1.2	Control element 11
	2.2	Front view 14
	2.3	Plan view 15
	2.4	Scope of delivery 15
	2.5	Type code 17
	2.6	Type label 18
Section 3	Safety	20
	3.1	Intended use 20
	3.1.1	Hazard analysis 21
	3.1.2	Electrical data 21
	3.1.3	Ambient conditions 21
	3.1.4	Guidelines for UL approval 21
	3.1.5	Safety function STO 22
	3.1.6	Use of qualified personnel 24
	3.1.7	Warranty and liability 24
	3.1.8	Disposal 24
	3.2	Safety during operation 25
	3.3	Standards 26
	3.4	Stop, emergency stop and emergency off functions 27
	3.4.1	Stop functions 27
	3.4.2	E-STOP functions 28
	3.4.3	Emergency stop functions 28
Section 4	Function Description	29
	4.1	Overview 29
	4.2	Power element 31
	4.2.1	Mains voltage 31
	4.2.2	Motor connection 35
	4.2.3	Motor holding brake 35
	4.2.4	Brake resistor 38
	4.2.5	Intermediate circuit 39
	4.2.6	Intermediate circuit topology 40
	4.3	Control element 43
	4.3.1	Supply voltage 24 VDC 44
	4.3.2	Digital inputs and outputs 44
	4.3.2.1	Overview 44
	4.3.2.2	Digital inputs 45

4.3.2.3	Digital outputs	47
4.3.3	Safety function STO	48
4.3.3.1	Safety guidelines	48
4.3.3.2	Signal states	49
4.3.3.3	Safety function STO without a safety card	49
4.3.3.4	Safety function STO with safety card	52
4.3.3.5	Reaction time	52
4.3.3.6	Connection example for STO, single-channel	52
4.3.3.7	Connection example for STO, dual-channel	53
4.3.4	Analogue inputs	54
4.3.5	Encoder systems	55
4.3.5.1	Overview	55
4.3.5.2	Resolver	61
4.3.5.3	Encoder	61
4.3.5.4	Incremental encoders	63
4.3.5.5	Absolute encoder with SSI interface	65
4.3.5.6	Hall encoder	65
4.3.6	Electronic gearing, Master-Slave mode	66
4.3.6.1	Stepper motor control systems (pulse/direction)	67
4.3.6.2	Master-Slave mode	67
4.3.7	Encoder emulation	68
4.3.8	Communications interfaces	71
4.3.8.1	RS232 interface	71
4.3.8.2	CANopen interface	71
4.3.8.3	Ethernet-based interface	71
4.3.9	SD card	72
4.3.10	Tools	72
4.4	Expansion cards	73
4.4.1	Expansion card PMCprotego S1-2, PMCprotego S2-2	73
4.4.2	Expansion card I/O-14/08	73
4.4.3	Expansion card PosI/O, PosI/O-AIO	75
4.4.3.1	Incremental encoder ROD (AquadB) 5V, (X5, X1)	76
4.4.3.2	Absolute encoder with SSI interface (X5, X1)	77
4.4.3.3	SinCos encoder with SSI interface (X5, X1)	77
4.4.3.4	Electronic gearing, Master-Slave mode	77
4.4.3.5	Encoder emulation	78
4.4.3.6	Analogue outputs	81
4.4.3.7	Analogue inputs	81
4.4.4	PROFIBUS DP interface expansion card	81
4.4.5	Expansion card PROFINET	82
4.4.6	Expansion card Fan Controller	82
4.5	Switch on/switch off behaviour	82
4.5.1	Normal mode	84
4.5.2	Fault condition	85
4.6	Implementation of stop categories	87
4.6.1	Stop Category 0	87
4.6.2	Stop Category 1	87
4.6.3	Stop Category 2	90

Section 5	Installation	93
	5.1 General requirements	93
	5.2 Dimensions	94
	5.3 Installing the servo amplifier	95
	5.4 Installing and removing the fan	97
	5.5 Installing the expansion cards	97
	5.5.1 Expansion cards for slot 1	98
	5.5.2 Expansion cards for slot 2	99
	5.5.3 Expansion cards for slot 3	100
Section 6	Wiring	101
	6.1 Connector description	101
	6.2 Block diagram	102
	6.3 Notes on wiring	104
	6.3.1 Contact protection	105
	6.3.1.1 Leakage current	105
	6.3.1.2 Residual current devices FI	106
	6.3.1.3 Isolating transformer	107
	6.3.2 Connection cables	107
	6.4 Wiring procedure	108
	6.5 EMC-compliant wiring	109
	6.5.1 Earthing	109
	6.5.2 Shielding	110
	6.5.2.1 Shield connection on the front plate	110
	6.5.2.2 Motor connection	111
	6.5.3 Filters	111
	6.5.4 Chokes	112
	6.6 Power element	112
	6.6.1 Mains voltage	112
	6.6.2 Motor with brake	114
	6.6.3 External brake resistor	116
	6.6.4 Intermediate circuit	117
	6.6.5 Energy store PMCenergy SD	119
	6.7 Control element	123
	6.7.1 Supply voltage 24 VDC	123
	6.7.2 Digital inputs	124
	6.7.3 Digital outputs	127
	6.7.4 Analogue inputs	128
	6.7.5 Encoder systems	129
	6.7.5.1 HIPERFACE DSL, one-cable connection	129
	6.7.5.2 SFD3, one-cable connection	131
	6.7.5.3 Resolver	132
	6.7.5.4 SinCos encoder with HIPERFACE interface	133
	6.7.5.5 SinCos encoder with EnDat 2.1 interface	135
	6.7.5.6 Encoder with EnDat 2.2 interface	137
	6.7.5.7 SinCos encoder with BISS interface, analogue	139
	6.7.5.8 Encoder with BISS interface, digital	141

6.7.5.9	SinCos encoder with SSI interface	143
6.7.5.10	SinCos encoder without data track	145
6.7.5.11	SinCos encoder with Hall encoder	147
6.7.5.12	Incremental encoder ROD (AquadB) 5 V, 350 kHz	149
6.7.5.13	Incremental encoder ROD (AquadB) 5 V, 1.5 MHz	151
6.7.5.14	Incremental encoder ROD (AquadB) 5 V, with zero pulse, with Hall encoder	153
6.7.5.15	Incremental encoder ROD (AquadB) 24 V, without zero pulse	155
6.7.5.16	Incremental encoder ROD (AquadB) 24 V, without zero pulse, with Hall encoder	156
6.7.5.17	Absolute encoder with SSI interface	158
6.7.5.18	Hall encoder	160
6.7.5.19	Electronic gearing, Master-Slave mode	162
6.7.5.20	Encoder emulation	164
6.7.6	Communications interfaces	165
6.7.6.1	RS232 interface	165
6.7.6.2	CANopen interface	167
6.7.6.3	Ethernet-based interface	168
6.8	Expansion cards	170
6.8.1	Expansion card PMCprotego S1, PMCprotego S2	170
6.8.2	Expansion card I/O-14/08	170
6.8.3	Expansion card PosI/O, expansion card PosI/O-AIO	173
6.8.3.1	Electronic gearing	173
6.8.3.2	Encoder emulation	175
6.8.3.3	Analogue inputs and outputs	177
6.8.3.4	Incremental encoder ROD (AquadB) 5 V	178
6.8.3.5	Absolute encoder with SSI interface	182
6.8.3.6	SinCos encoder with SSI interface	183
6.8.4	PROFIBUS DP interface expansion card	186
6.8.5	PROFINET interface expansion card	187
Section 7	Commissioning	188
7.1	Safety guidelines	188
7.2	Commissioning the servo amplifier	189
7.3	Download firmware from SD card to servo amplifier	195
7.4	LEDs and keys	196
7.4.1	Key functions	196
7.4.2	Status indicator	196
7.4.3	Standard menu	197
7.4.4	Advanced menu	198
7.5	Messages/errors	198
7.5.1	Status messages	198
7.5.2	Error messages	199
7.5.3	Warnings	200
7.6	Safety checks	201
7.7	Expansion cards	202
7.7.1	PROFIBUS DP interface expansion card	202
7.7.2	PROFINET interface expansion card	202

Section 8	Technical details PMCprotego D.01/230 V	203
Section 9	Technical details PMCprotego D.01/480V	207
Section 10	Technical details PMCprotego D.03/230 V	211
Section 11	Technical details PMCprotego D.03/480V	219
Section 12	Technical details PMCprotego D.06/230 V	223
Section 13	Technical details PMCprotego D.06/480V	227
Section 14	Technical details PMCprotego D.12/230 V	231
Section 15	Technical details PMCprotego D.12/480V	235
Section 16	Technical details PMCprotego D.12 P/230 V	239
Section 17	Technical details PMCprotego D.12 P/480V	243
Section 18	Technical details PMCprotego D.24/230 V	247
Section 19	Technical details PMCprotego D.24/480V	251
Section 20	Technical details PMCprotego D.24 P/230 V	255
Section 21	Technical details PMCprotego D.24 P/480V	259
Section 22	Safety characteristic data	263
Section 23	Order reference	264
	23.1 Order reference for device	264
	23.2 Order reference for accessories	264
	23.2.1 Safety cards to retrofit or as spare part	264
	23.2.2 Expansion cards to retrofit or as spare part	265
	23.2.3 Interface cable, interface adapter, SD card	265
	23.2.4 Connector for cable assembly, motor power cable	265
	23.2.5 Connector set as spare part	265
	23.2.6 Y connector	265
	23.2.7 Energy store	265
	23.2.8 Connection cable to the motor series "PM Ctendo SZ"	266
Section 24	Appendix	267
	24.1 Abbreviations	267
Section	Glossary	269

1 Introduction

1.1 Validity of documentation

This documentation is valid for the PMCprotego D. It is valid until new documentation is published.

This operating manual explains the product's function and operation, describes the installation and provides guidelines on how to connect the PMCprotego D.

Please also refer to the following documents from the motion control range:

- ▶ The online help for the commissioning software describes how to set the parameters for the servo amplifier.
- ▶ The "PMCprimo CAN Networking" manual contains guidelines for networking multiple PMCprimo control systems and additional CANopen devices.

All these manuals can be found on the supplied CD-ROM: "Motion Control Documentation".

You will need to be conversant with the information in these documents in order to fully understand this manual.

This operating manual is valid for the following products:

- ▶ PMCprotego D.01 from Version 1.6
- ▶ PMCprotego D.03 from Version 1.6
- ▶ PMCprotego D.06 from Version 1.6
- ▶ PMCprotego D.12 from Version 1.6
- ▶ PMCprotego D.12 P from Version 1.6
- ▶ PMCprotego D.24 from Version 1.6
- ▶ PMCprotego D.24 P from Version 1.6

1.1.1 Retaining the documentation

This documentation is intended for instruction and should be retained for future reference.

1.2 Definition of symbols

Information that is particularly important is identified as follows:



DANGER!

This warning must be heeded! It warns of a hazardous situation that poses an immediate threat of serious injury and death and indicates preventive measures that can be taken.



WARNING!

This warning must be heeded! It warns of a hazardous situation that could lead to serious injury and death and indicates preventive measures that can be taken.

**CAUTION!**

This refers to a hazard that can lead to a less serious or minor injury plus material damage, and also provides information on preventive measures that can be taken.

**NOTICE**

This describes a situation in which the product or devices could be damaged and also provides information on preventive measures that can be taken. It also highlights areas within the text that are of particular importance.

**INFORMATION**

This gives advice on applications and provides information on special features.

2 Overview

2.1 Unit structure

2.1.1 Unit features

The PMCprotego D is a compact servo amplifier consisting of

- ▶ A **power element**
- ▶ A **control element** with
 - Inputs and outputs
 - Sequence control
 - Control loops for current, speed and position
 - Interfaces for communication with the periphery

Unit types:

- ▶ Units are available with a range of output currents and widths
- ▶ C type
 - Devices with coated PCB boards, see [Type code](#)  17].

2.1.1.1 Power element

The servo amplifier's power element has the following features:

- ▶ Connection to earthed three-phase supplies, rated voltage ranges
 - 230 V series: 1 x 110 V – 3 x 230 V
 - 480 V series: 3 x 208 V – 3 x 480 V
- ▶ TN network and TT network with earthed star point, symmetrical rated current, connection to other networks only with isolating transformer
- ▶ B6 rectifier bridge integrated directly on the three-phase, earthed network, mains filter and start-up circuit
- ▶ Single-phase supply possible (e.g. for commissioning or set-up mode)
- ▶ Fuse protection (e.g. blow-out fuse) through user
- ▶ All shield connections directly on the servo amplifier
- ▶ Max. intermediate circuit voltage in generator mode:
 - 230 V series: 135 V – 450 VDC
 - 480 V series: 260 V – 900 VDC
 - Can be connected in parallel
- ▶ Brake chopper, brake power distributed over several amplifiers on the same intermediate circuit
- ▶ Internal brake resistor is standard, external brake resistor available on request
- ▶ Optionally, an energy store can be connected to the intermediate circuit (see [Energy store PMCenergy SD](#)  119])
- ▶ Inverted rectifier with isolated current measurement and IGBT transistors
- ▶ Unit versions with continuous output currents from 1.5 A - 24 A

- ▶ Device types with increased peak output currents (-P option, see type code and technical details)
- ▶ Connection of synchronous servo motors, linear motors, asynchronous motors
- ▶ Integrated noise suppression filters in accordance with EN 61800-3

2.1.1.2

Control element

The servo amplifier's control element has the following features:

Supply voltage

- ▶ Supply voltage 24 VDC
- ▶ Controller supply isolated from fan and brake, fused internally
- ▶ Integrated noise suppression filters in accordance with EN 61800-3

Encoder systems

Integrated evaluation of the following encoder systems

- ▶ Resolver
- ▶ Incremental encoder
- ▶ Absolute encoder
 - with or without SinCos tracks
 - with various interfaces

Inputs and outputs

- ▶ 2 analogue voltage inputs
 - Differential input
 - Signal range: ± 10 V, referenced to earth
 - Resolution (with sign bit): 16 Bit
- ▶ 4 digital inputs
 - 2 of these digital inputs are suitable for fast signals
- ▶ 2 digital inputs or outputs (switchable signal direction)
- ▶ Pulse/direction 24 V
- ▶ All digital signals are free to be linked

Digital control

- ▶ Digital control loop
- ▶ Digital speed regulator
- ▶ Digital position controller
- ▶ Pulse/direction interface for connecting a servo motor to a stepper motor controller

Setting the parameters

- ▶ With the commissioning software, via the serial interface
- ▶ With the motion control system PMCprimo C, via the CAN interface in conjunction with the commissioning software and CoDeSys (development environment in accordance with IEC 61131-3)
- ▶ Via the PROFINET-/ETHERNET parameter channel (PASmotion)
(Requirement: The expansion card PROFINET is inserted)

Operation and display

- ▶ Servo amplifier operated via two keys
- ▶ Three-digit LED display for status and messages

Integrated safety

- ▶ Device safety
 - Safe electrical isolation between mains voltage/motor connection and control element, in accordance with EN 61800-5-1
 - Soft start, overvoltage detection, short circuit protection, phase failure monitoring
 - Temperature monitoring of servo amplifier and motor (when using Pilz motors with ready-made cables)
- ▶ Protection of personnel and plant
 - Safety function STO – Safe Torque Off
 - Single-channel without feedback: Up to PL d (Cat. 2) of EN ISO 13849-1 and SIL CL 2 of EN/IEC 62061
 - Dual-channel with feedback: Up to PL e (Cat. 4) of EN ISO 13849-1 and SIL CL 3 of EN/IEC 62061
 - Slot for safety card: Safety functions for safe operation of drive axes in accordance with DIN IEC 61800-5-2, up to PL e (Cat. 4) of EN ISO 13849-1 and SIL CL 3 of EN/IEC 62061

Communication interfaces

- ▶ CANopen interface for
 - Connection to CAN bus systems
 - Parameters for several drives can be set via a servo amplifier's serial interface
- ▶ RS232 interface for parameter setting with the commissioning software
- ▶ Ethernet-based interface
 - EtherCAT

Card slot for SD card

- ▶ Card slot for SD card, for reading and writing parameters and firmware

Expansion cards

3 slots for expansion cards

- ▶ Expansion cards for slot 1:
 - I/O-14/08
 - PROFIBUS DP
 - PROFINET
- ▶ Expansion cards for slot 2:
 - PMC expansion card PosI/O
 - PMC expansion card PosI/O-AIO
 - Fan controller, available only on request

**INFORMATION**

An expansion card in slot 1 can be used in conjunction with a fan controller expansion card in slot 2. Other than that, only expansion cards can occupy slot 1 or slot 2 (for combinations see [Type code \[📖 17\]](#)).

- ▶ Expansion cards for slot 3:
 - PMCprotego S1, PMCprotego S1-2
 - PMCprotego S2, PMCprotego S2-2
 - PMC expansion card PosI/O
 - PMC expansion card PosI/O-AIO
 - Fan controller, available only on request

2.2 Front view

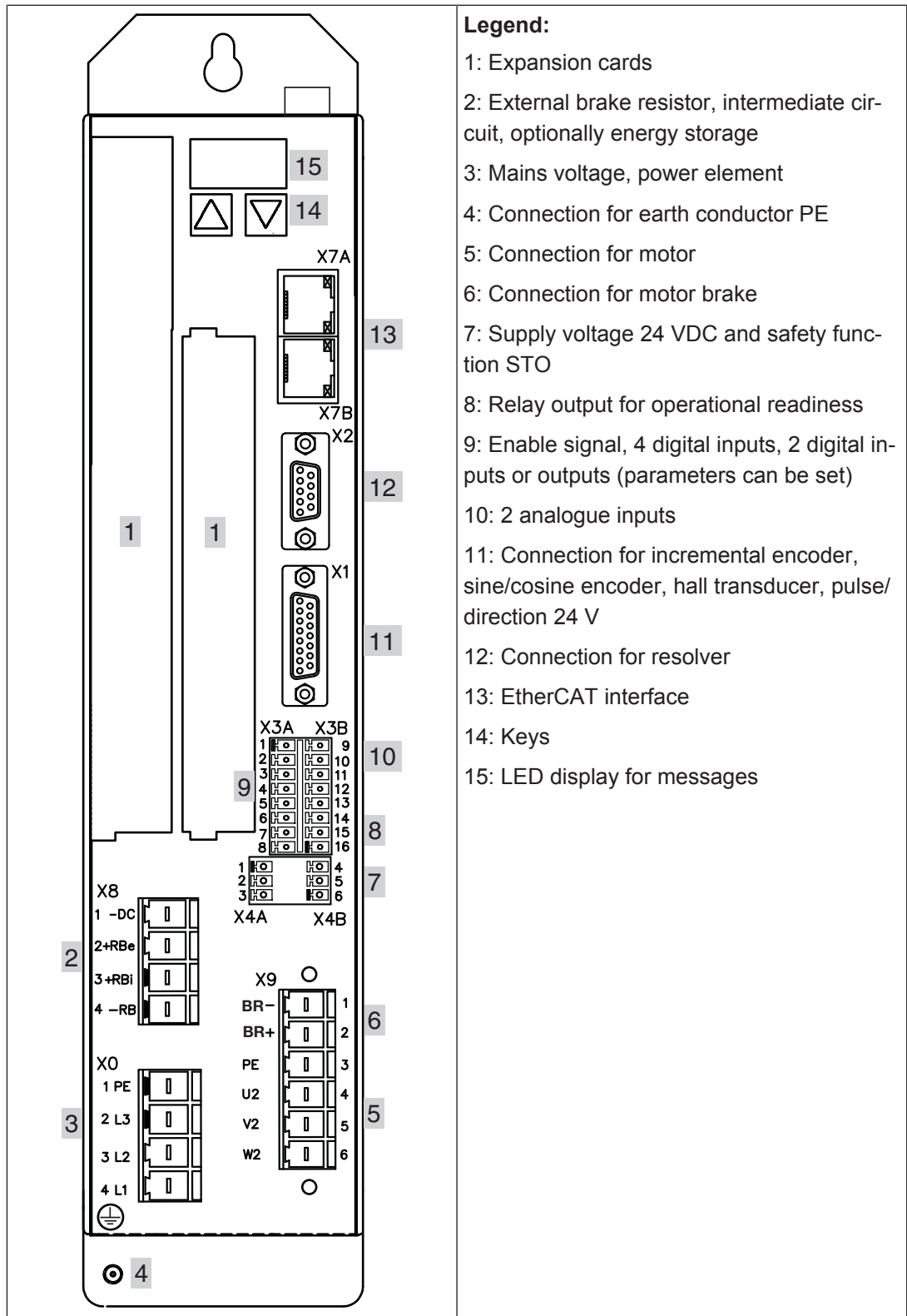

Front view of the PMCprotego D

2.3 Plan view

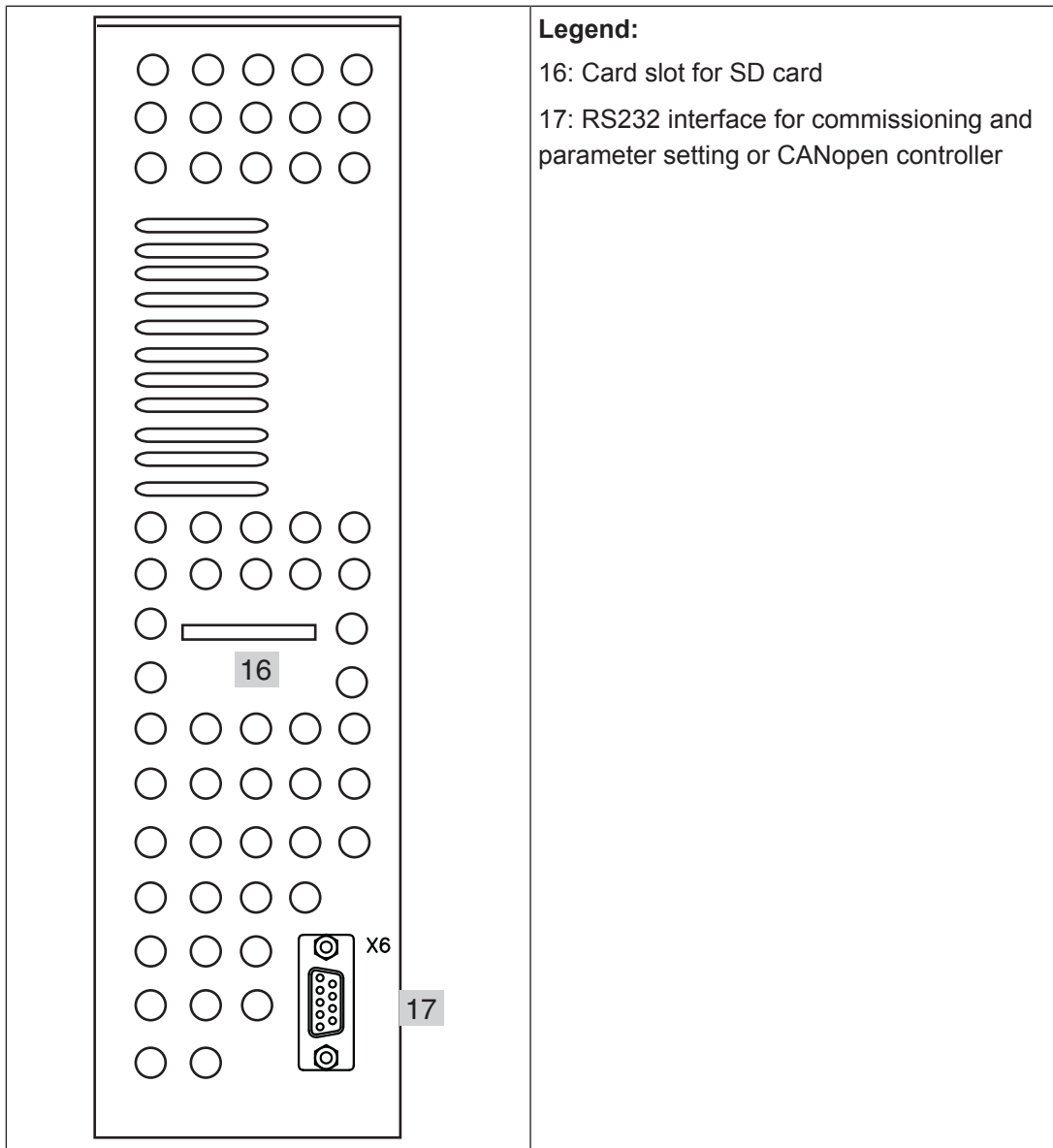

Plan view of the PMCprotego D

2.4 Scope of delivery

This is what you receive when you order a servo amplifier from the PMCprotego series:

- ▶ Servo amplifier PMCprotego D
- ▶ Mating connectors X0, X3, X4, X8
- ▶ Documentation CD
- ▶ Commissioning software (PASmotion) on the Internet

**INFORMATION**

The D-Sub mating connectors, the motor connector and the fieldbus junction box are not supplied with the device! They are available as accessories.

2.5 Type code

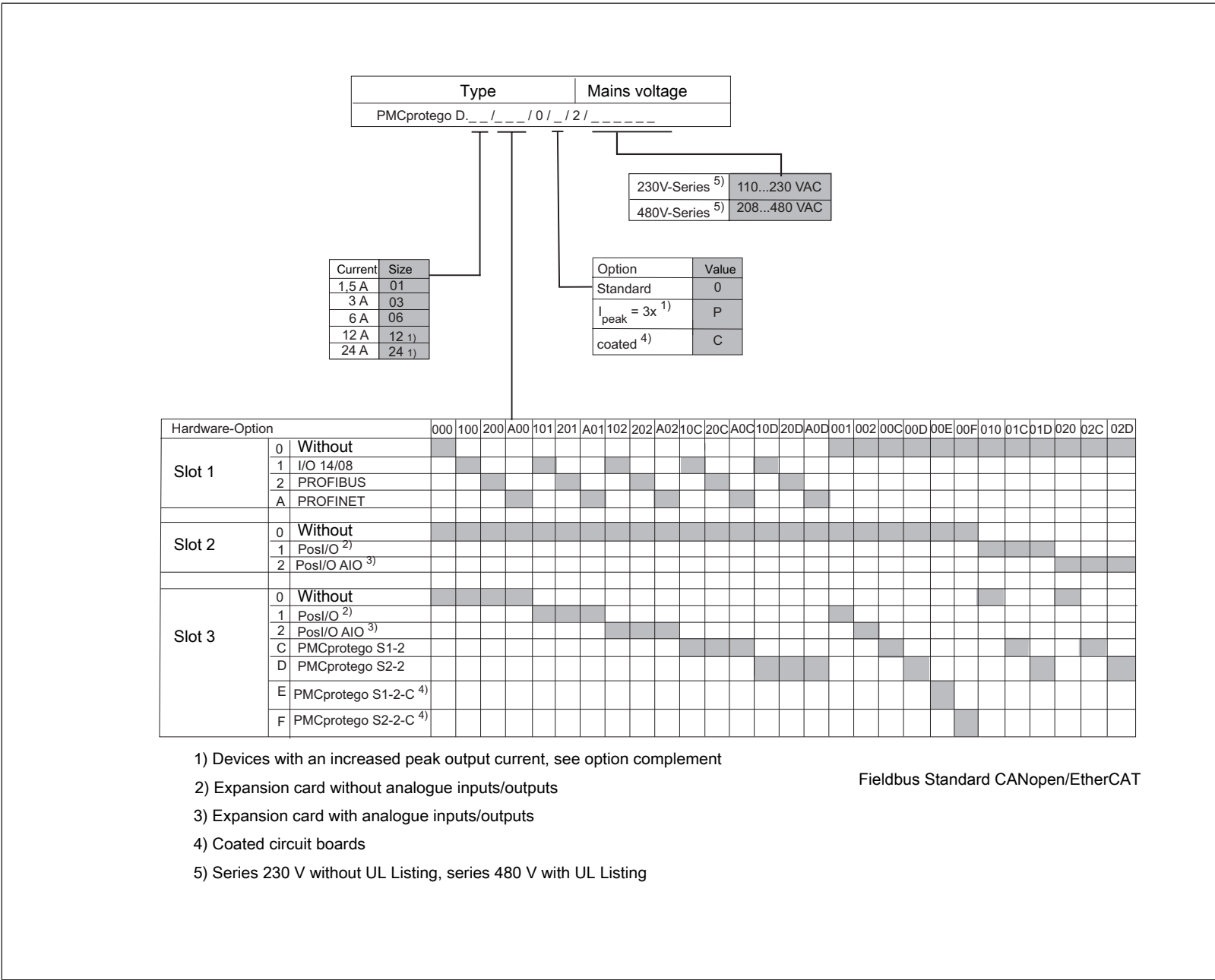

2.6 Type label

The type label is situated on the side of the servo amplifier.

The type label consists of:

- ▶ Type label modified device
- ▶ Type label standard device



INFORMATION

Type label

Always state the full details on the "Type label modified device" (configuration) in new orders or spare parts orders.



Fig.: Type label modified device

Legend

new type	Modified type key
Ident. No.	Order number
Ser. No.	Serial number
Firmware	Firmware version

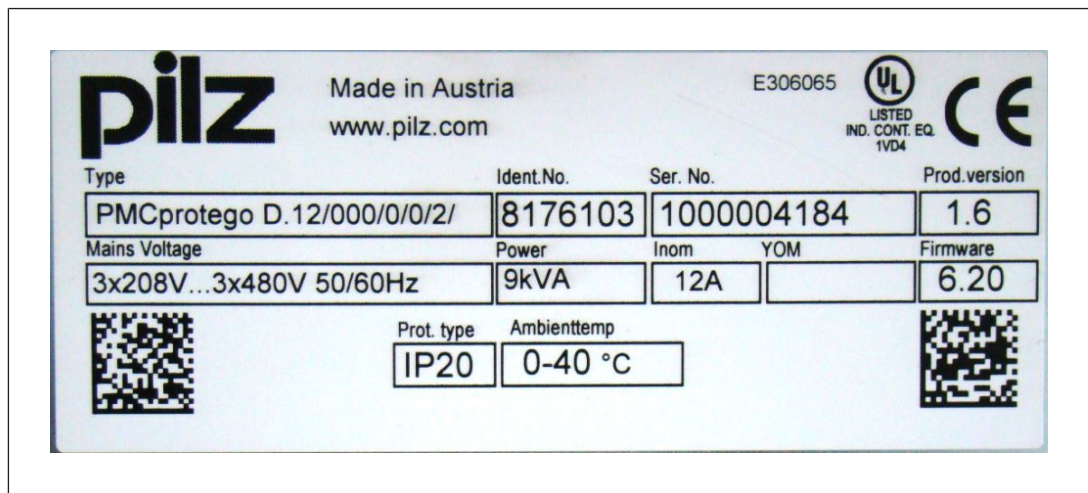

Fig.: Type label standard device

Legend

Type	Type key
Ident. No.	Order number
Prod. version	Product version
Firmware	Firmware version
Mains Voltage	Mains voltage
Power	Power
Inom	Continuous output current
YOM	Year of manufacture
Prot. type	Protection type
Ambient temp	Ambient temperature

3 Safety

3.1 Intended use

The servo amplifiers PMCprotego D are designed to drive suitable brushless, synchronous servo motors and asynchronous motors with closed loop speed, torque and/or position control.

The following is deemed improper use:

- ▶ Any component, technical or electrical modification to the servo amplifier
- ▶ Use of the servo amplifier outside the areas described in this manual
- ▶ Use of the servo amplifier outside the documented technical details (see chapter entitled "Technical Details")

Intended use includes making the installation and wiring EMC-compliant. Please refer to the guidelines stated in this manual.

The servo amplifier is not classified under Annex 1 (Category 3, AL-3A225) of the EC Dual-Use Regulation No. 428/2009, when the commutation frequency for sensorless operation of asynchronous motors (motor type MTYPE=3) is limited to less than 600 Hz. The cutoff frequency was set to 599 Hz.

Conversion of commutation frequency into the speed:

Speed (rpm) = commutation frequency · 60 / number of pole pairs of the motor

Example: 12-pole asynchronous motor, commutation frequency = 599 Hz

Speed (rpm) = 599 Hz · 60 / (6 pole pairs) = 5990 rpm

From the following product and firmware version, the devices follow the export regulations of the EC Dual-Use Regulation:

- ▶ PMCprotego D.XX
 - Product version: 1.4
 - Firmware version: 5.71

Please refer to the type label of the device for product and firmware versions. A query is possible with the terminal:

→ VER

V5.71 ND0

- ▶ "ND0": not export-restricted device, firmware with limited commutation frequency in sensorless operation

Servo amplifiers with higher commutation frequencies are available only on request.



INFORMATION

On servo amplifiers from firmware version 5.71, no firmware version prior to Version 5.71 can be loaded. It is possible to downgrade from Version 5.73 to 5.71, for example.

3.1.1 Hazard analysis

The machine manufacturer must produce a hazard analysis for the machine. He must take appropriate measures to ensure that unexpected movements do not lead to hazardous situations for either people or equipment.

3.1.2 Electrical data

Please note the electrical requirements stated in the chapters entitled "Technical Details", "Wiring" and "Function Description".

3.1.3 Ambient conditions

Please note the following conditions for using the servo amplifier:

- ▶ Operation of the servo amplifier is forbidden in the following conditions:
 - Potentially explosive areas
 - Environments containing corrosive and/or conductive acids, alkaline solutions, oils, fumes or dusts
 - Where there is a direct connection to unearthed or asymmetrically earthed mains supplies with $U_N > 240$ V. See chapter entitled "Wiring", under "Mains voltage".
 - On ships and offshore installations
- ▶ The servo amplifier may **only** be operated in an enclosed control cabinet in compliance with the ambient conditions defined under "Technical details". Ventilation or cooling may be required to maintain the control cabinet temperature below 40 °C.



WARNING!

In a residential environment this product may cause high-frequency noise, so that suppression measures may be required.

3.1.4 Guidelines for UL approval



NOTICE

UL approval depends on the device

PMCprotegoD: Mains voltage 208 – 480 V is listed under the UL File Number E306065

PMCprotegoD: Mains voltage 110 – 230 V is not UL listed

The devices are certified to UL 508C and UL 840.

- ▶ UL 508C describes the fulfilment by design of minimum requirements for electrically operated power converters, such as frequency converters and servo amplifiers.
- ▶ UL 840 describes the fulfilment by design of clearance and creepage distances on electrical equipment and printed circuit boards.

UL Markings

- ▶ Use 60°C or 75°C copper wire only for every model of this section.
- ▶ Use Class 1 wire only.
- ▶ Tightening torque for field wiring terminals:
X0, X8, X9: 0.7 - 0.8Nm (6.20 to 7.08 lbf in)
- ▶ Use in a pollution degree 2 environment.
- ▶ These devices provide solid state motor overload protection at 130% of full load current.
- ▶ Integral solid state short circuit protection does not provide branch circuit protection. Branch circuit protection must be provided in accordance with the National Electrical Code and any additional local codes.
- ▶ These devices are not provided with motor over-temperature sensing.
- ▶ Suitable for use on a circuit capable of delivering not more than 42kA rms symmetrical amperes for a max. voltage of 480 Vac.
- ▶ Supply circuit protection:

Model	Fuse class	Rating	Max. Fuse Rating
PMCprotego D.01	RK5, CC, J, T	600 VAC 200 kA	6 A (Time delay)
PMCprotego D.03	RK5, CC, J, T	600 VAC 200 kA	6 A (Time delay)
PMCprotego D.06	RK5, CC, J, T	600 VAC 200 kA	10 A (Time delay)
PMCprotego D.12 PMCprotego D.12 P	RK5, CC, J, T	600 VAC 200 kA	15 A (Time delay)
PMCprotego D.24 PMCprotego D.24 P	RK5, CC, J, T	600 VAC 200 kA	30 A (Time delay)

- ▶ The drives may be connected together via the “common bus” (DC bus link) based on the instructions on p. 70ff. The devices may also be grouped from the AC input side based on the max. input fuse (e.g. 3 pcs. PMCprotego D.01 with one common 6A fuse in line).

3.1.5 Safety function STO

The safety function "Safe torque off" (STO) activates the pulse disabler on the servo amplifier and removes the power to the motor. It meets the requirements in accordance with EN 61800-5-2.

The inputs STO1-ENABLE and STO2-ENABLE, when

- ▶ with single-channel activation without feedback, meet the requirements in accordance with EN ISO 13849-1: PL d (Cat. 2) and EN/IEC 62061: SIL CL 2.
- ▶ With dual-channel activation with feedback, in accordance with EN ISO 13849-1: PL e (Cat. 4) and EN/IEC 62061: SIL CL 3.

**NOTICE**

With dual-channel activation of the inputs STO1-ENABLE and STO2-ENABLE, the safe pulse disabler must be tested periodically to ensure it switches safely. See section 4.3.3, entitled "Safety function STO".

The safety card PMCprotego S1 or PMCprotego S2 can also be used to trigger the safety function STO.

The STO1-ENABLE input on the servo amplifier has no function if the servo amplifier contains a safety card. In this case, the safety card activates the safe pulse disabler on the servo amplifier in order to shut down the power element.

The safety function "safe torque off" corresponds to a category 0 stop (uncontrolled stop) in accordance with EN 60204-1.

Improper use STO

The safety function STO may not be used when the drive is to be stopped for the following reasons:

- ▶ Cleaning, maintenance and repair work, long interruptions in operation
Remove the voltage from the entire plant and secure it (main switch).
- ▶ Switching off the energy supply of the servo amplifier
(see standard EN 60204, emergency switching stop).

Before carrying out any work on the machine, you must comply with the five safety rules in the order stated:

- Enable (switch off the voltage.)
Also disconnect the auxiliary circuits.
- Secure against reconnection
- Verify that the system is dead
- Carry out earthing and short circuiting
- Provide protection from adjacent live parts.

**DANGER!****Risk from rotating motor after STO has been triggered!**

The safety function STO switches the motor to torque-free. On motors without a safe holding brake, moving parts present a threat to life.

Use an additional mechanical measure to block the drives safely (e.g. with the motor holding brake), particularly with suspended loads.

**DANGER!****Risk from non-safety-related activation of the motor holding brake!**

Activation of a holding brake via output BR+/BR- of the servo amplifier is not safety-related. Depending on the application, hazardous motor movements may cause serious injury or death.

A motor holding brake activated by the servo amplifier alone is **not suitable for personal protection**.

Block the drive through an additional mechanical holding brake, which is activated safely (e.g. with the safety card PMCprotego S1-2).

3.1.6 Use of qualified personnel

The products may only be assembled, installed, programmed, commissioned, operated, maintained and decommissioned by competent persons.

A competent person is a qualified and knowledgeable person who, because of their training, experience and current professional activity, has the specialist knowledge required. To be able to inspect, assess and operate devices, systems and machines, the person has to be informed of the state of the art and the applicable national, European and international laws, directives and standards.

It is the company's responsibility only to employ personnel who

- ▶ Are familiar with the basic regulations concerning health and safety / accident prevention,
- ▶ Have read and understood the information provided in the section entitled Safety
- ▶ Have a good knowledge of the generic and specialist standards applicable to the specific application.

3.1.7 Warranty and liability

All claims to warranty and liability will be rendered invalid if

- ▶ The product was used contrary to the purpose for which it is intended,
- ▶ Damage can be attributed to not having followed the guidelines in the manual,
- ▶ Operating personnel are not suitably qualified,
- ▶ Any type of modification has been made (e.g. exchanging components on the PCB boards, soldering work etc.).

3.1.8 Disposal

- ▶ In safety-related applications, please comply with the mission time T_M in the safety-related characteristic data.
- ▶ When decommissioning, please comply with local regulations regarding the disposal of electronic devices (e.g. Electrical and Electronic Equipment Act).

3.2 Safety during operation



DANGER!

While the devices are in operation there is a risk of death or serious injury and material damage.

- Do not open or touch the devices during operation.
- Keep all covers and cabinet doors closed during operation.
- When the devices are switched on, they should only be touched during commissioning by qualified staff.
- During operation the servo amplifiers may contain live, uninsulated components, depending on their protection type.
- Control and power connections may still carry voltage, even when the motor is not rotating.
- Surfaces on the servo amplifiers may become hot during operation. Temperatures may reach more than 80° C.



DANGER!

In unfavourable conditions arcing may occur, causing potential injury to persons and damage to electrical contacts.

- For this reason, never unplug the electrical connections on the servo amplifier while voltage is applied.
- After disconnecting the servo amplifier from the mains voltages, wait at least eight minutes before touching any parts that carry voltage (e.g. contacts) or loosening the connections.
- After the mains voltages have been switched off, capacitors continue to carry hazardous voltages for up to 8 min. (5 min. for 1.5 to 12 A types, 8 min. for 24 A types).
- To be safe, measure the voltage in the intermediate circuit and wait until the voltage has dropped below 40 VDC.



DANGER!

While the devices are in operation there is a risk of death or serious injury and material damage.

When the supply voltage is switched on, do not:

- Open the housing
- Connect or disconnect connection terminals
- Connect or disconnect a connection wiring
- Install or remove accessories

3.3 Standards

Servo amplifiers are components designed for incorporation into electrical plant or machinery within the industrial sector. The servo amplifier may not be used for its intended purpose until it has been established that the plant or machinery complies with the provisions of the following directives:

- ▶ EU Machinery Directive (2006/42/EC)
- ▶ EU EMC Directive (2014/30/EU)
- ▶ EU Low Voltage Directive (2014/35/EU)

Standards for compliance with the EU Machinery Directive (2006/42/EC)

- ▶ EN 60204-1 (Safety and electrical equipment of machines)
- ▶ EN 12100 (Safety of machinery)

The machine manufacturer must produce a hazard analysis for the machine and take appropriate measures to ensure that unexpected movements do not cause injury to people or damage to equipment.

Standards for compliance with the EU Low Voltage Directive (2014/35/EU)

- ▶ EN 60204-1 (Safety and electrical equipment of machines)
- ▶ EN 60439-1 (Low voltage switchgear and controlgear assemblies)
- ▶ EN 61800-5-1 (Adjustable speed electrical power drive systems - Safety requirements)

Standards for compliance with the EU EMC Directive (2014/30/EU)

- ▶ EN 61000-6-1/2 (Immunity for residential, commercial and light-industrial environments)
- ▶ EN 61000-6-3/4 (Emission standard for residential, commercial and light-industrial environments)
- ▶ EN 61800-3 (Adjustable speed electrical power drive systems - EMC requirements)

It is the manufacturer's responsibility to comply with the limit values for the plant or machinery as required by EMC legislation. This documentation contains tips on how to make your installation EMC-compliant (such as shielding, earthing, how to manage the connectors and lay the cables).

UL conformity

- ▶ UL 508C

UL 508C describes the fulfilment by design of minimum requirements for electrically operated power conversion equipment, such as frequency converters and servo amplifiers, which are intended to eliminate the risk of these devices causing a fire.

- ▶ UL 840

UL 840 describes the fulfilment by design of clearance and creepage distances on electrical equipment and printed circuit boards.

Functional safety standards

- ▶ EN 61800-5-2 (Adjustable speed electrical power drive systems – Safety requirements – Functional)
- ▶ EN ISO 13849-1 (Safety of machinery – Safety-related parts of control systems)
- ▶ EN 61508-1 (Functional safety of electrical/electronic/programmable electronic safety-related systems – General requirements)

- ▶ EN 61508-2 (Functional safety of electrical/electronic/programmable electronic safety-related systems – Requirements)
- ▶ EN 61508-3 (Functional safety of electrical/electronic/programmable electronic safety-related systems – Software requirements)
- ▶ EN 61508-4 (Functional safety of electrical/electronic/programmable electronic safety-related systems – Definitions and abbreviations)
- ▶ IEC 62061 (Safety of machinery - Functional safety of safety-related electrical, electronic and programmable electronic control systems)

The machine or plant manufacturer must check to see whether any additional standards or EU directives are applicable for his plant or machinery.

3.4 Stop, emergency stop and emergency off functions

The safety function STO can protect the drive against unintended start-up when the power supply is present after standstill (up to SIL CL3 of EN 62061 and PL e of EN 13849-1).

The parameters "STOPMODE" and "ACTFAULT" must be set to 1 if the stop and emergency stop categories are to be implemented. Change the parameters in the commissioning software terminal, if necessary (PASmotion).

3.4.1 Stop functions

The stop function is used to bring the machine to a standstill in normal operation.

The stop functions are defined in EN 60204-1.

category 0

Stopping by immediate removal of power to the machine actuators (uncontrolled stop). The safety function STO can be used for this.

category 1

A controlled stop, with power to the machine actuators available to achieve the stop and then removal of power when the stop is achieved.

category 2

A controlled stop, with power left available to the machine actuators.

The stop category shall be determined from the hazard analysis of the machine.

Appropriate measures to ensure a reliable stop are also required.

Category 0 or 1 stops shall be operational regardless of the operating mode. A Category 0 stop shall take priority. Stop functions shall operate by de-energising the relevant circuit and shall override related start functions.

Where required, facilities to connect protective devices and interlocks shall be provided. Where applicable, the stop function shall signal that such a condition exists. The reset of the stop function shall not initiate any hazardous conditions.

Safety functions in accordance with EN 61800-5-2 such as SS1 (safe stop 1) and SS2 (safe stop 2) can be implemented either with the safety card or with external safety relays combined with the STO function.

3.4.2 E-STOP functions

The E-STOP function is used to **stop the machine as fast as possible** in the case of danger. The E-STOP function can be initiated by the action of a single person. It must be functional and available at all times. The user should not have to consider how to operate the device.

The E-STOP function is defined by EN 60204-1. Principles of E-STOP equipment and functional aspects are established in ISO 13850.

The stop category for the emergency stop shall be determined from the hazard analysis of the machine.

In addition to the requirements for stop, the emergency stop has the following requirements:

- ▶ The E-STOP shall override all other functions and operations in all modes.
Power to the machine actuators, which can cause hazardous conditions, shall be
 - removed as quickly as possible without creating other hazards (e.g. category 0 stop with safety function STO).
 - or
 - controlled in such a way that the hazardous movement is stopped as quickly as possible (stop category 1).
- ▶ Reset shall not initiate a restart.

3.4.3 Emergency stop functions

The emergency stop function is used to shut down the electrical supply to the machine in order to exclude hazards created by electrical power (e.g. electric shock). Functional aspects for emergency stop are defined in IEC 60364-5-53.

The emergency stop is triggered manually by a single human action e.g. via a positive-opening pushbutton (red pushbutton on a yellow background).

The results from a hazard analysis of the machine determine whether an emergency stop is required.

The emergency stop is achieved by shutting down the energy supply using electromechanical relays. This leads to a Category 0 stop. The emergency stop must be implemented using other measures (e.g. protection against direct contact) if a Category 0 stop is not permitted for the machine.

4 Function Description

4.1 Overview

The PMCprotego D is a digital servo amplifier which drives servo motors with closed loop speed, torque and/or position control. It is suitable for closed loop operation of

- ▶ Brushless, synchronous servo motors.
- ▶ Asynchronous motors.
- ▶ Linear synchronous motors.

The servo amplifier consists of

- ▶ A **power element**, which converts the fixed voltage and frequency of the mains into a variable voltage and frequency for driving the motor
- ▶ A **control element** with
 - Sequence control and control loops for rotational speed/velocity and position
 - Interfaces for communication with the periphery or the commissioning software PASmotion
 - Digital inputs and outputs
 - Analogue inputs
 - Safety circuits
 - Bus interfaces: CAN, EtherCAT
 - RS232 interface for parameter setting and commissioning

The following illustration shows the components that make up the servo amplifier.

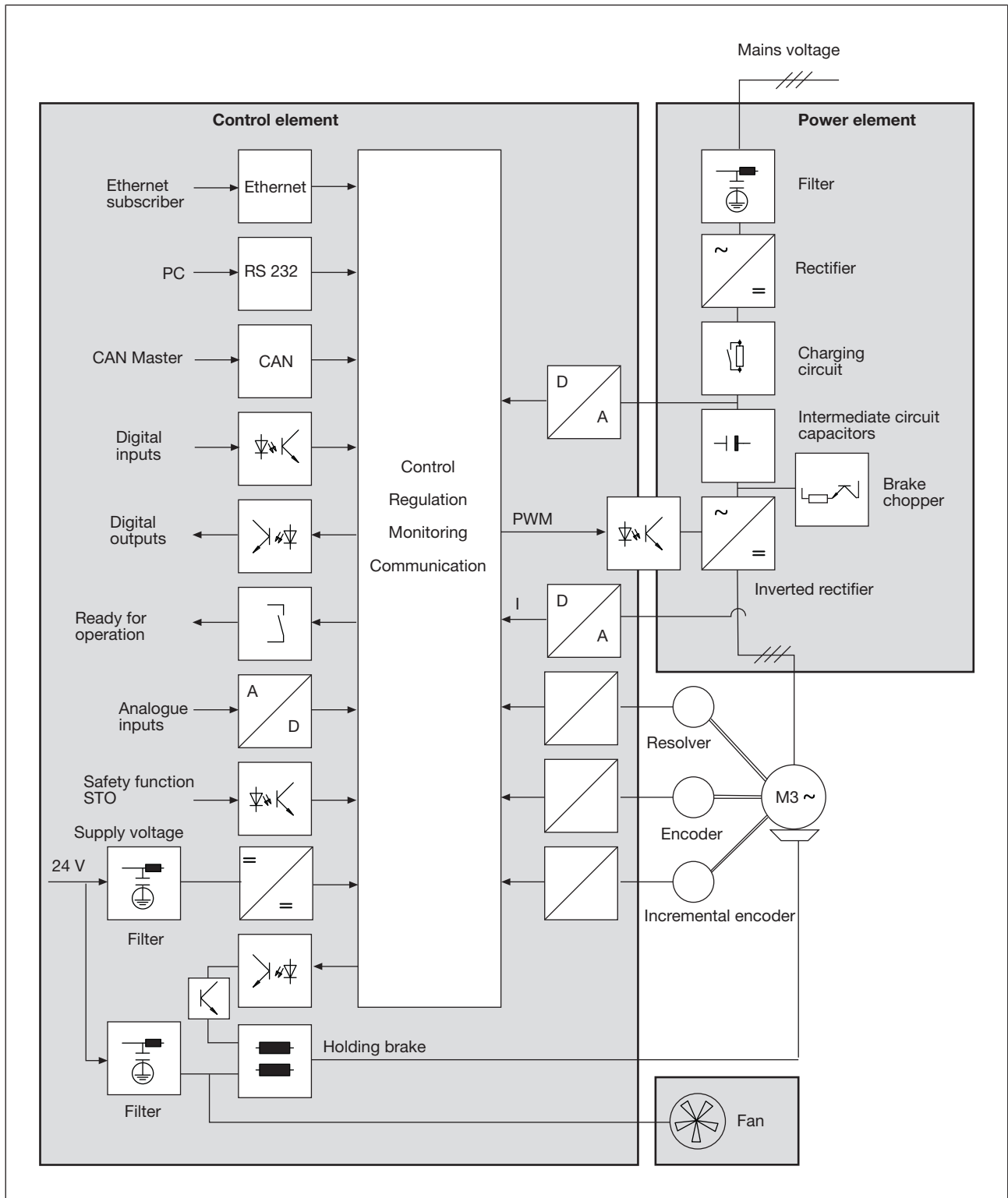

Fig.: Block diagram of PMCprotego D

4.2 Power element

The power element of the servo amplifier converts the fixed voltage and frequency of the mains into a variable voltage and frequency for driving the motor. This means that the rotational speed and torque are infinitely variable. The power element consists of

- ▶ EMC filter A
- ▶ Rectifier B
- ▶ Charging circuit with intermediate circuit C
- ▶ Brake chopper D
- ▶ Inverted rectifier E

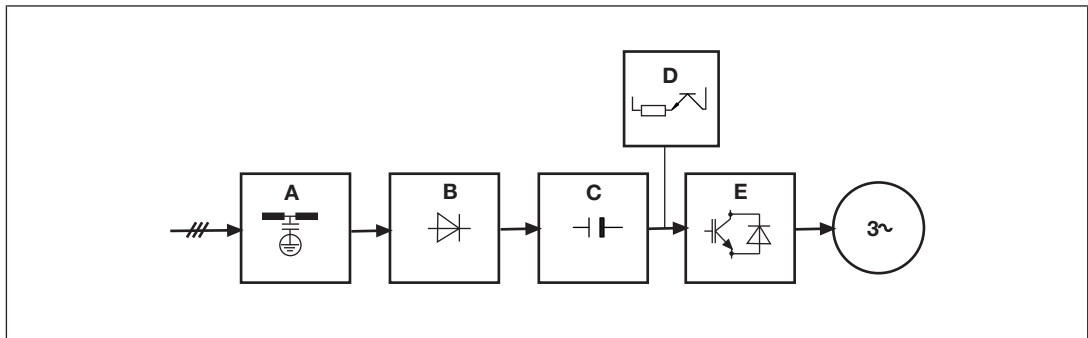

Fig.: Power element

4.2.1 Mains voltage



CAUTION!
Risk of overvoltage

Overvoltage can destroy the device and lead to minor injuries.
Select the correct mains voltage and the correct device type.



DANGER!
Risk of electrocution

If the servo amplifier is not earthed correctly, there is a risk of serious injury or death due to electric shock.

Use isolating transformers for asymmetrically earthed or unearthed 400 V ... 480 V supplies.

The servo amplifier is suitable for connection to TT and TN networks. The voltage range of the servo amplifier is 1 x 110 VAC – 3 x 230 VAC or 3 x 208 VAC - 3 x 480 VAC.

Please note the maximum permitted voltages between the external conductors (L1, L2, L3) and the servo amplifier housing:

- ▶ Periodic overvoltages between the external conductors and the housing: Max. 1000 V (amplitude)

- ▶ Voltage spikes ($< 50 \mu\text{s}$) in accordance with EN 61800 between the external conductors: max. 1000 V
- ▶ Voltage spikes ($< 50 \mu\text{s}$) between the external conductors and housing: max. 2000 V
- ▶ Max. 42 kA symmetrical rated current

Direct connection to PMCprotego D

- ▶ 110 – 230 V mains supplies without earthed star point (asymmetrically earthed or un-earthed mains supplies), see Fig. (2) – (6)
- ▶ 110 – 230 V mains supplies with earthed star point, see Figure (1)
- ▶ 208 – 240 V mains supplies without earthed star point (asymmetrically earthed or un-earthed mains supplies), see Fig. (2) – (6)
- ▶ 208 – 480 V mains supplies with earthed star point, see Figure (1)

Connection via isolating transformer

- ▶ 400 – 480 V mains supplies without earthed star point (asymmetrically earthed or un-earthed mains supplies), see Fig. (7) – (11)

Requirements for isolating transformers

- ▶ An earthed star point must be available on the secondary side. The star point on the secondary side must be earthed and must be connected to the servo amplifier's protective earth conductor. This will prevent overvoltages between the external conductors and the servo amplifier housing.
- ▶ The isolating transformers must have the relevant input and output voltages.

The following illustrations shows the connection types.

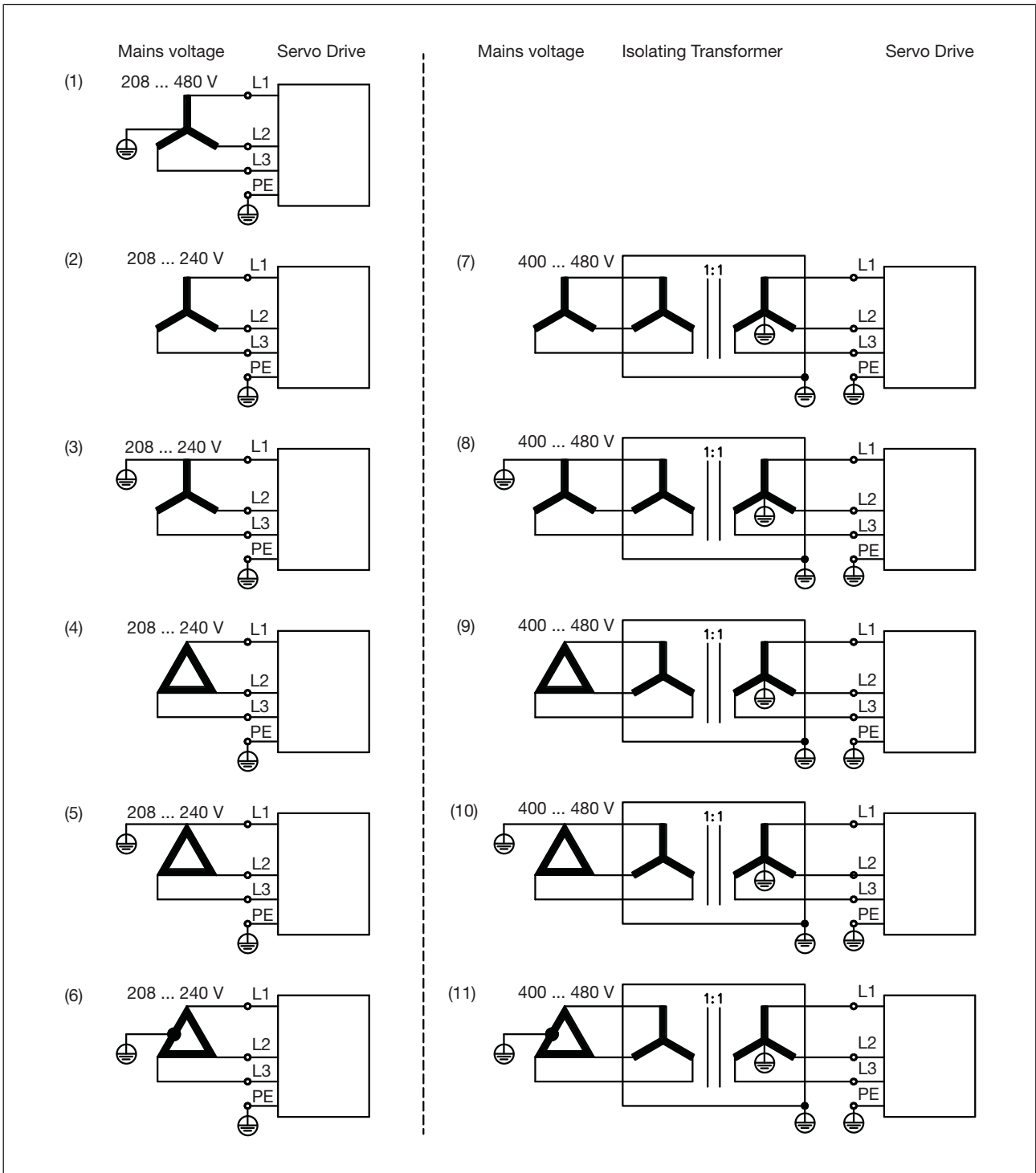

Fig.: Connection types for the mains connection

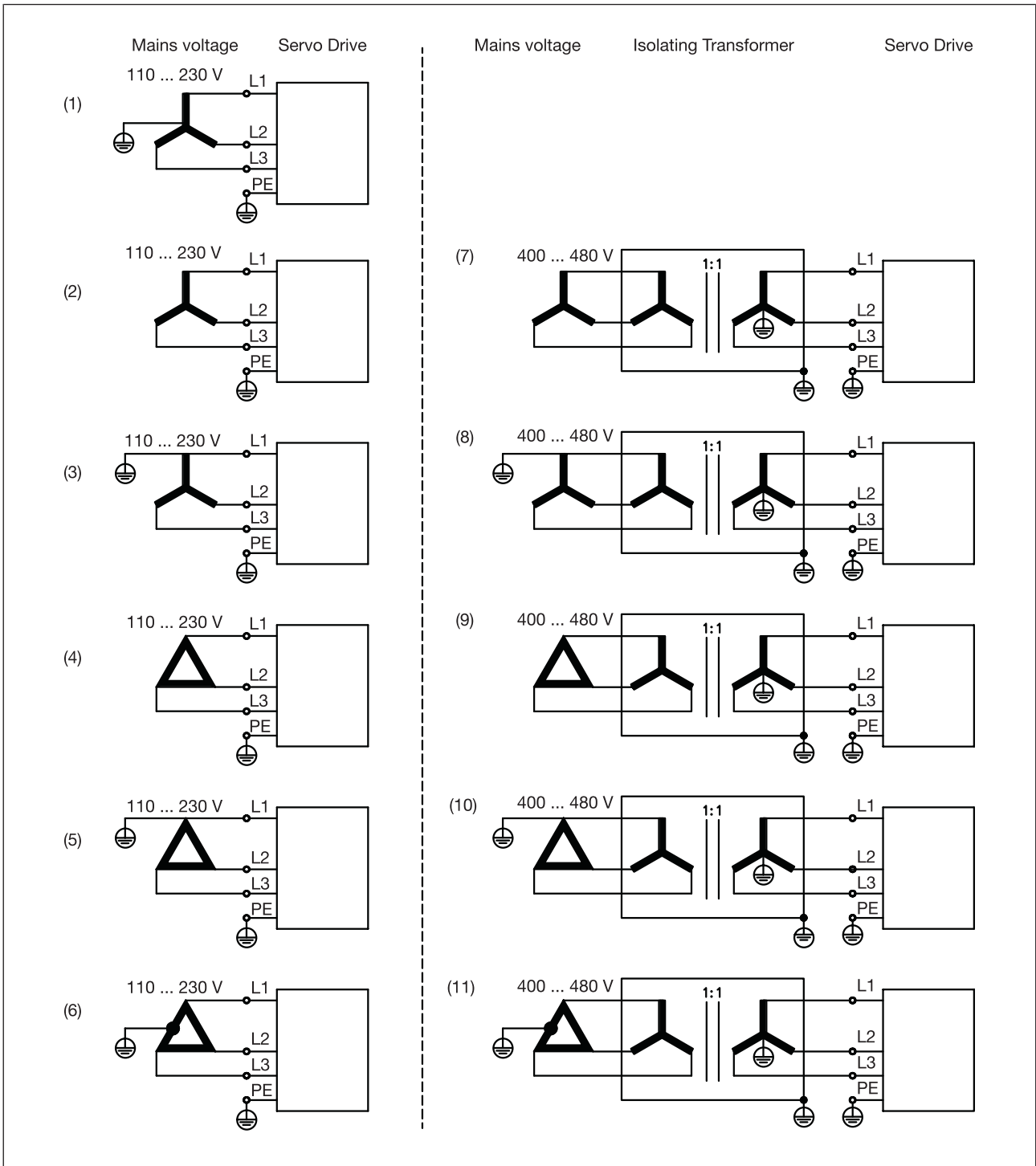

Fig.: Connection types for the mains connection

4.2.2 Motor connection

The servo amplifier controls the motor with a variable frequency 3-phase sequence. The motor holding brake is also controlled.

- ▶ The rated voltage U_N of the motors must comply with the following value:
 $U_N \geq U_{ZK} \cdot 0.707$
 U_{ZK} : Intermediate circuit voltage
- ▶ Thermal switches and motor feedback systems on the servo motor are evaluated.
- ▶ In the commissioning software (PASmotion) it is possible to select from a database the appropriate data record and parameters to suit the Pilz motor.
- ▶ Motor cables are available ready-assembled from Pilz as an accessory.

The power element, motor cable and motor winding form an oscillating circuit. Variables that determine the voltage generated within the system:

- ▶ Cable capacitance
- ▶ Cable length
- ▶ Motor inductance
- ▶ Frequency
- ▶ Speed of the voltage rise

Please note the information provided in the technical details and the specification of the motor you are using.

4.2.3 Motor holding brake

The servo amplifier can control a motor holding brake (24 VDC, max. 2 A) directly. The motor holding brake is supplied by the control element's supply voltage. Ensure that the power supply is adequately sized (see "Technical details").



DANGER!

Risk from non-safety-related activation of the motor holding brake!

Activation of a holding brake via output BR+/BR- of the servo amplifier is not safety-related. Depending on the application, hazardous motor movements may cause serious injury or death.

A motor holding brake activated by the servo amplifier alone is **not suitable for personal protection**.

Block the drive through an additional mechanical holding brake, which is activated safely (e.g. with the safety card PMCprotego S1-2).

**CAUTION!**

Inadequate supply voltage to the motor holding brake can result in a hazardous situation, leading to serious injury and death. The control of the motor holding brake is not safety-related.

Please consider the power loss due to cable lengths and transition resistances!

Measure the voltage at the brake input!

Test the function of the brakes by releasing and applying the brake.

Setting the parameters

The brake function must be enabled in the commissioning software (PASmotion) via the **Brake** option ("Motor" window).

Timing diagram

The timing diagram shows the relationship between the ENABLE signals, the speed setpoint, the speed and the braking power, in terms of time and function. All times can be set via parameters. The times in the timing diagram are default values.

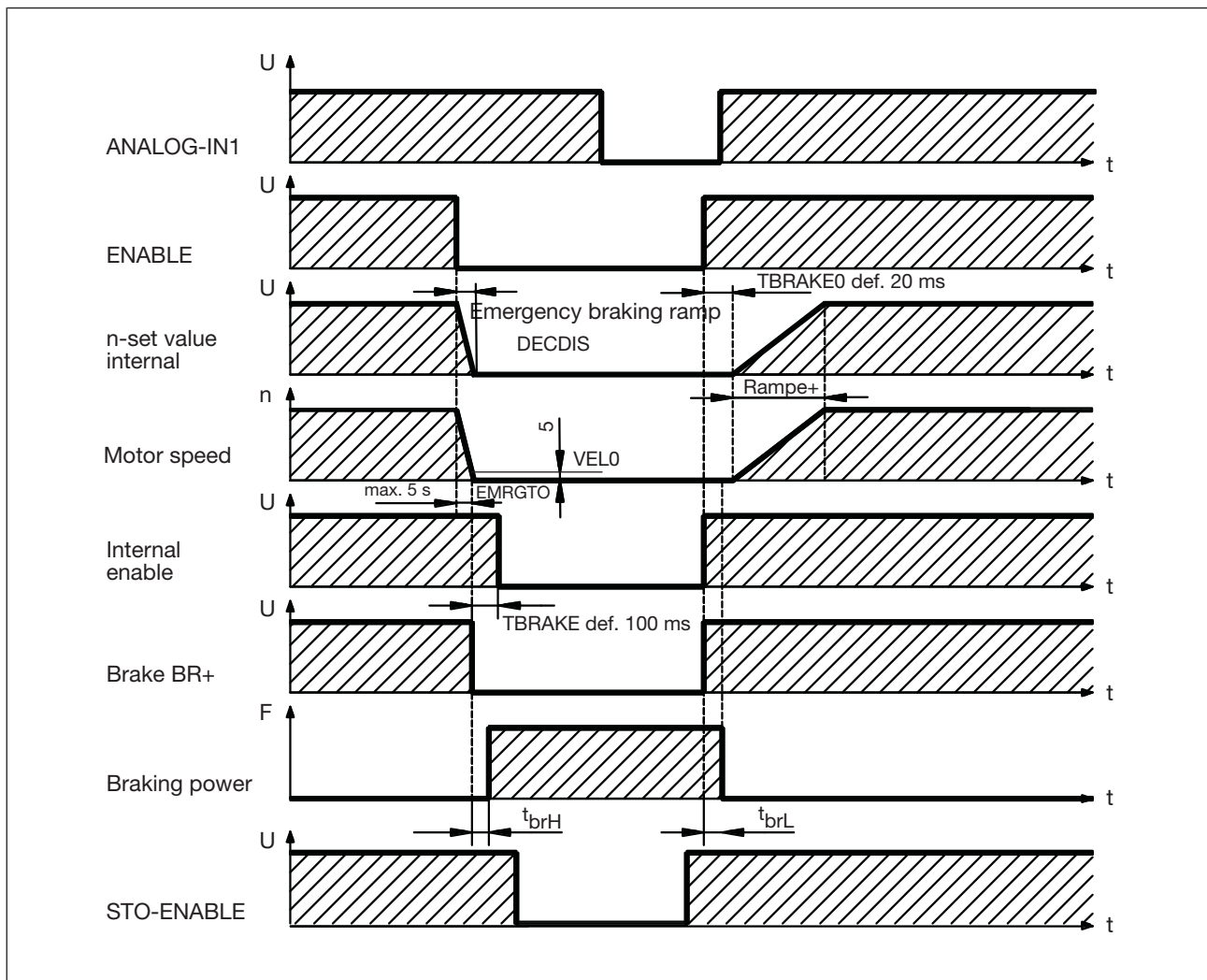

Fig.: Timing diagram for motor holding brake

- ▶ The speed setpoint is brought from 100 ms to 0 within the internal delay time (internal ENABLE). The emergency braking ramp DECDIS is selectable.
- ▶ The brake output BR+ switches at a speed of 5 rpm (VEL0) or after 5 s at the latest (EMRGTO).
- ▶ The rise times (t_{brH}) and fall times (t_{brL}) of the motor holding brake depend on the motor type (see motor documentation).

Safe actuation of the motor holding brake

Safe actuation of the holding brake also requires

- ▶ The N/O contact or safe semiconductor output from a safety relay within the braking circuit.
- ▶ A suppression device (e.g. varistor or flywheel diode).

One of the safety cards PMCprotego S1-2 or PMCprotego S1-2-C can also be used for safe actuation of the motor holding brake.

Wiring suggestion:

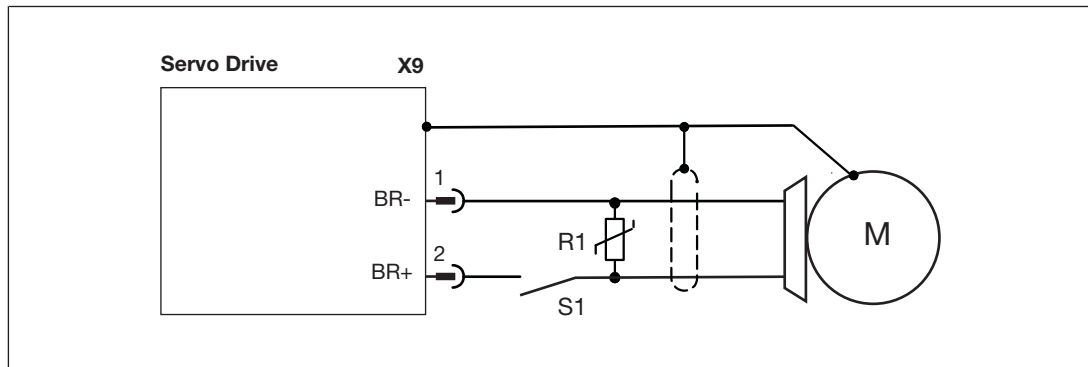

Fig.: Safe motor holding brake

R1: Suppression device

S1: N/O contact from a safety relay

4.2.4 Brake resistor

When the servo motor is braked, energy is fed back to the servo amplifier. This means that the capacitors in the intermediate circuit are charged at higher voltages. The servo amplifier switches the brake resistor to the intermediate circuit via the brake chopper. The brake resistor converts the braking energy into heat.

The servo amplifier has integrated brake resistors. Alternatively, external brake resistors may be connected.

Setting the parameters

The thresholds for connecting the brake resistor to the mains voltage of the servo amplifier are adjusted in the commissioning software (PASmotion).

Our Customer Support team can help you calculate the brake power you will need for your plant.

Single-axis or multi-axis systems

- ▶ Single amplifier
 - If the power regenerated from the motor is greater than the set brake power (as an average over time or as a peak value), a message will appear (see section entitled “Messages/Errors”).
 - The servo amplifier detects overvoltage on the intermediate circuit. The power element shuts down. The following error message appears: “F02: Overvoltage”.
 - The relay contact for operational readiness, BTB/RTO, opens.
- ▶ Multiple servo amplifiers **interconnected** via the intermediate circuit (DC+, DC-)
 - Multiple servo amplifiers of the same series with mains voltage from the same mains can be operated on a common intermediate circuit.
 - 90% of the **total output** of all the servo amplifiers is always available for peak and continuous output. In the case of overvoltage, the amplifier shuts down at the lowest shutdown threshold based on the tolerance (as described above for the single amplifier).
- ▶ The technical details for the brake resistor depend on the type of servo amplifier and the mains voltage.

4.2.5 Intermediate circuit

Multiple servo amplifiers can be interconnected via the direct current intermediate circuit ("intermediate circuit" for short). This interconnection is termed a multi axis system.

This connection:

- ▶ Balances the braking and operating energy of multiple axes.
- ▶ Distributes the braking energy over multiple brake resistors.

Optionally, an energy store can be connected (see [Energy store PMCenergy SD](#) [ 119]).



NOTICE

High transient currents between connected intermediate circuits can destroy the servo amplifier. v

- Supply the servo amplifier from the same mains (identical mains voltage).
- Do not wire servo amplifiers with smaller outputs between two servo amplifiers with higher outputs.
- Ensure that the total rated currents of all the servo amplifiers connected in parallel in an intermediate circuit does not exceed 48 A.

4.2.6 Intermediate circuit topology

Information on fuses, depending on the device type, can be found in chapter [Mains voltage](#) [112].

Connection with Y connectors

The sum of all the nominal currents switched in parallel to a PMCprotego D servo amplifier must not exceed 48 A. If this upper current limit is not exceeded, the amplifiers (with 6 mm² connections) can be connected using Y connectors. The Y connectors are available as an accessory.

Without an intermediate circuit fuse protection further devices can be damaged or destroyed when a device fails, for example because of an internal short circuit. If several amplifiers are to be switched in parallel, it makes sense to insert intermediate circuit fuses between amplifier groups (a group consists of two or three devices, depending on the current strength), to limit a possible consequential damage. The fuse cannot entirely prevent a consequential damage by current peaks.

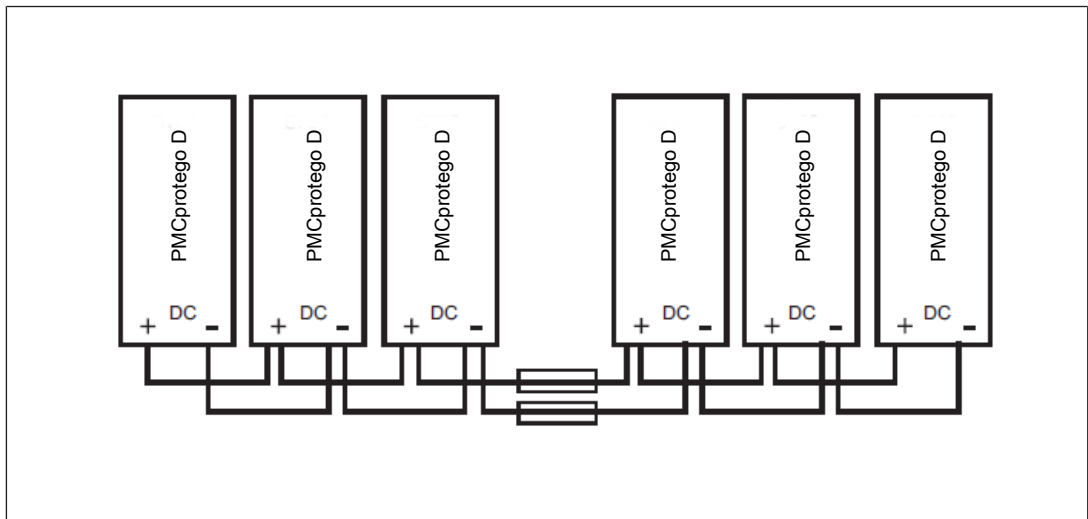

Fig.: Connection with Y connector

Group fuse connection using intermediate circuit fuses

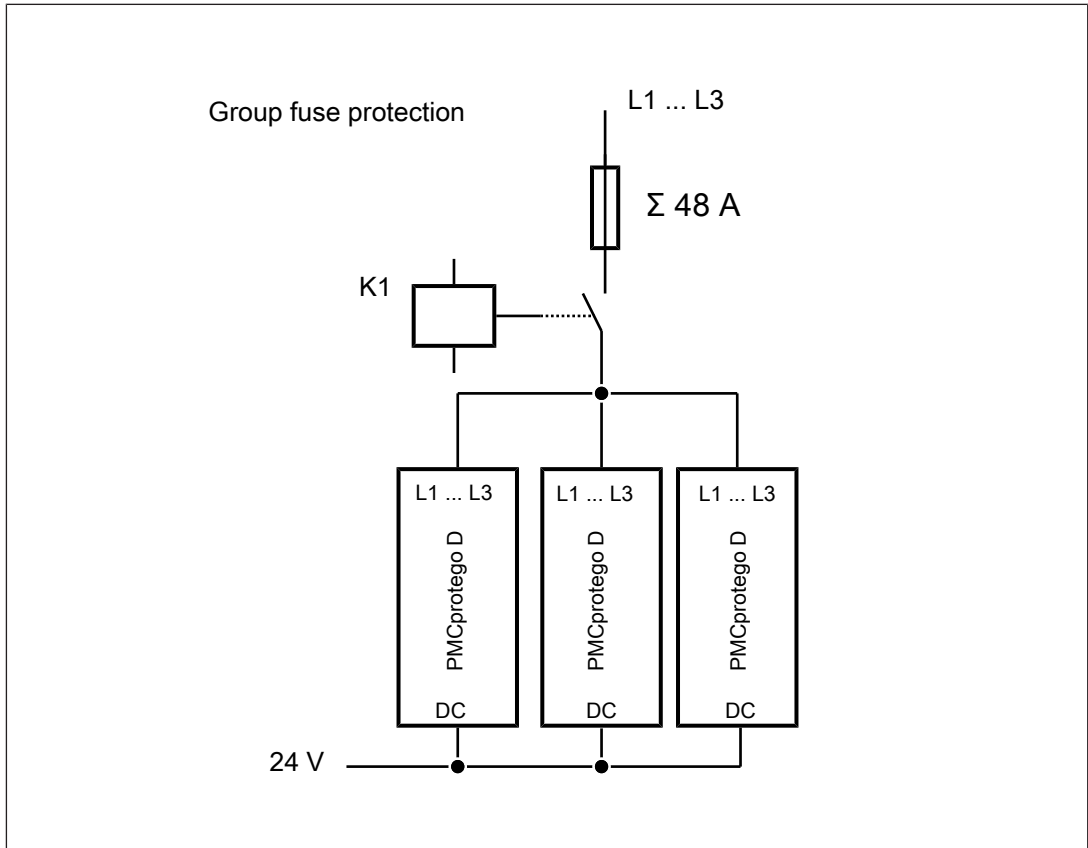

Fig.: Example group fuse protection

Group fuse protection in CE region

Groups of the power supply can be formed using Y connectors.

The following applies: Maximum fuse protection with 30 A/32 A when using 6 mm² connections.

The sum of nominal currents or the servo amplifiers that are to be combined in a group must not exceed **24 A!**

Recommended

A sensible maximum group size is 4 – 5 devices. In theory, 16 x PMCprotego D 01 (16 x 1.5 A = 24 A) could be combined, for example.

Fuse protection nominal current in A	Device type PMCprotego	Wiring in mm ²	Note
30/32	D24	6	Device single!
30/32	D12	6	Group of 2
30/32	1 x D12 + 2 x D06	6	Group of 3
30/32	4 x D06	6	Group of 4

Fuse protection nominal current in A	Device type PMCprotego	Wiring in mm ²	Note
30/32	4 x D03 + 1 x D12	6	Group of 5

Examples for possible device groups in the CE region

Group fuse protection in UL region

The servo amplifiers PMCprotego D 24/12/06 (24 A, 12 A, 6 A) have to be fuse protected individually.

Only devices with the nominal currents 3 A and 1.5 A can be protected in groups with a max. of 6 A.

The following applies: Maximum fuse protection with 6 A when using the relevant AWG connections.

The sum of nominal currents of the servo amplifiers that are to be combined in a group must not exceed **6 A!**

Fuse protection nominal current in A	Device type PMCprotego	Wiring in AWG	Note
30	D24	9	Device single!
15	D12	11	Device single!
10	D6	15	Device single!
6	2 x D03	15	Group of 2
6	1 x D03 + 2 x D01	15	Group of 3
6	4 x D01	15	Group of 4

Examples for possible device groups in the UL region

Connection with power rail

The wiring does not require Y connectors. The fuses are useful to protect the devices, as above. If a device fails because of a short circuit, only its intermediate circuit fuses blow and the further combination will continue undisturbed. The relatively bulky power rail can conduct a much higher current because the equalising current flows over the connector, not as described above. Therefore it is possible to connect almost any numbers of servo amplifiers in parallel. This arrangement is often sensible also for connecting an energy store (see [Energy store PMCenergy SD](#) [ 119]).

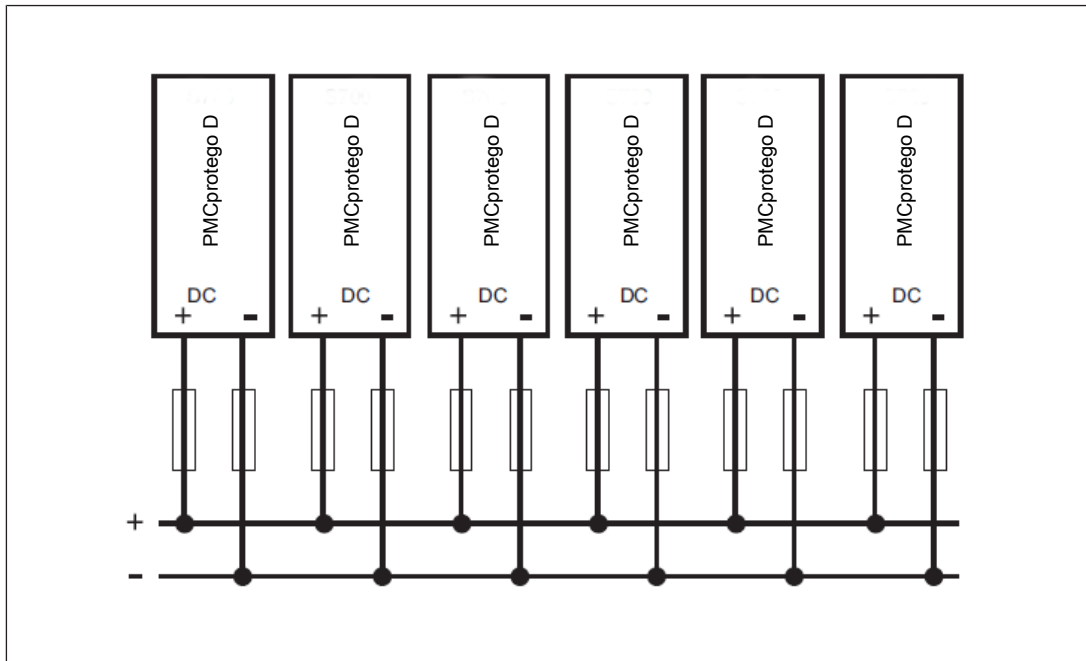

Fig.: Connection with power rail

4.3 Control element

The control element has the following tasks:

- ▶ Controls the semiconductor on the power element
- ▶ Exchanges data between the servo amplifier and periphery
- ▶ Records and displays errors and messages
- ▶ Performs protective functions for the servo amplifier and motor

Processing of the setpoints with current, speed and position controllers is fully digital.

For communication with the periphery the servo amplifier has

- ▶ Digital inputs and outputs
- ▶ Analogue inputs for specifying the controller setpoint
- ▶ Connections for encoder systems
- ▶ Interfaces for connecting a PC (e.g. for configuration and commissioning) or a higher level control system

4.3.1 Supply voltage 24 VDC

The control element is fed with 24 V from an isolated external power supply. Please note the information provided under “Technical Details”.



WARNING!

Electric shock!

Safe electrical isolation must be ensured for the external power supply that generates the supply voltage. Failure to do so could result in electric shock. The power supplies must comply with EN 60950-1, 05/2006, EN 61558-2-6, 11/1997.

4.3.2 Digital inputs and outputs

4.3.2.1 Overview

The PMCprotego D has digital inputs and outputs for a range of applications.

The digital signals can be logically linked within the commissioning software (PASmotion).

Connectors/terminals	Designation	Quantity	Type	Signal range	Scan rate	Application
X3A/2, 3	DIGITAL-IN1 DIGITAL-IN2	2	Semiconductor input	IEC 61131-2 Type 1	500 kHz	Fast input signals
X3A/4, 5	DIGITAL-IN3 DIGITAL-IN4	2	Semiconductor input	IEC 61131-2 Type 1	4 kHz	Evaluation of limit switches
X3A/1	ENABLE	1	Semiconductor input	IEC 61131-2 Type 1	4 kHz	Enable signal from controller
X3A/6, 7	DIGITAL-INOUT1 DIGITAL-INOUT2	2	Semiconductor input or output	IEC 61131-2 Type 1	4 kHz	Signal output from pre-programmed functions
X3B/14, 15	BTO/RTO	1	Relay output	Max. 30 VDC Max. 42 VAC		Operational readiness

Connectors/terminals	Designation	Quantity	Type	Signal range	Scan rate	Application
X4B/6	STO1-ENABLE	1	Semiconductor input	20 - 30 V		Safety function STO 1st shutdown route Safety-related
X4A/3	STO2-ENABLE	1	Semiconductor input	20 - 30 V		Safety function STO 2nd shutdown route Safety-related

4.3.2.2

Digital inputs

ENABLE (X3A/1)

Functions:

- ▶ A "1" signal enables the inverted rectifier of the servo amplifier in order to drive the motor.
- ▶ The enable is only possible if the inputs STO1-ENABLE and STO2-ENABLE are connected for the safety function in accordance with the application (see section: "Digital inputs STO1-ENABLE (X4B/6), STO2-ENABLE (X4A/3)").
- ▶ In a disabled condition ("0" signal), the connected motor is torque-free.
- ▶ PLC-compatible (IEC 61131-2 Type 1), volt-free, reference earth is DGND

Further information and connection examples can be found in this chapter under "Safety function STO".

Setting the parameters:

- ▶ A software enable is also required in the commissioning software (PASmotion) (AND connection).
- ▶ The enable can also be permanently activated ("Basic Setup" window in the commissioning software).

Programmable digital inputs (X3A/2 ... 7)

Functions:

- ▶ Digital inputs X3A/2 ... 7 can be used to initiate pre-programmed functions stored in the servo amplifier.

Setting the parameters:

- ▶ A list of the pre-programmed functions is available in the "Digital I/O" window of the commissioning software (PASmotion).
- ▶ If a pre-programmed function has been newly assigned, the data record must be stored in the servo amplifier's EEPROM and the device must be reset (e.g. using the commissioning software PASmotion).

Digital inputs DIGITAL-IN1 ... 2 (X3A/2, 3)

Functions:

- ▶ These fast inputs are suitable for latch functions or rapid feedback signals, for example.
- ▶ PLC-compatible (IEC 61131-2 Type 1), volt-free, reference earth is DGND

Digital inputs DIGITAL-IN3 ... 4 (X3A/4, 5)

Functions:

- ▶ These inputs can be assigned to evaluate limit switches (PSTOP and NSTOP), for example.
- ▶ PLC-compatible (IEC 61131-2 Type 1), volt-free, reference earth is DGND

Setting the parameters:

- ▶ Select the required function in the commissioning software ("Digital I/O" window).

Digital inputs DIGITAL-INOUT 1 ... 2 (X3A/6, 7)

Functions:

- ▶ Pin 6 and 7 on X3A can either be used as an input or output. Select the required function in the commissioning software ("Digital I/O" window).
- ▶ PLC-compatible (IEC 61131-2 Type 1), volt-free, reference earth is DGND

Setting the parameters:

- ▶ Select whether they should be used as input or output in the commissioning software ("Digital I/O" window).

**INFORMATION**

The inputs are active high or low, depending on the selected function.

Safety function STO, digital inputs STO1-ENABLE (X4B/6), STO2-ENABLE (X4A/3)

The two digital inputs STO1-ENABLE (1st shutdown route) and STO2-ENABLE (2nd shutdown route) are used to shut down the inverted rectifier safely.

Functions when operated **without** a safety card:

- ▶ The digital inputs STO1-ENABLE and STO2-ENABLE enable the inverted rectifier on the servo amplifier.
- ▶ Single or dual-channel activation of the safety function STO is possible.
- ▶ The servo amplifier is ready for operation when there is a 24 V signal at the inputs.
- ▶ If the STO1-ENABLE and/or STO2-ENABLE input is open, no more power is transferred to the motor. The drive becomes torque-free and runs down.
- ▶ In conjunction with the output from a safety relay or safety control system, you can safely prevent the drive from restarting.
- ▶ Requirements of the outputs on a safety control system or safety relay:
 - Single-channel activation of STO without feedback: PL d (Cat. 2) of EN ISO 13849-1, SIL CL 2 of EN/IEC 62061
 - Dual-channel activation of STO with feedback: PL e (Cat. 4) of EN ISO 13849-1, SIL CL 3 of EN/IEC 62061

- ▶ If the safety function STO is **not** needed, STO1-ENABLE and STO2-ENABLE must be connected directly to 24 V.

- ▶ Volt-free, reference earth is XGND

Functions when operated **with** a safety card:

- ▶ PL e (Cat. 4) and SIL CL 3 can be achieved.

- ▶ Volt-free, reference earth is XGND

- ▶ STO1-ENABLE

The input STO1-ENABLE is **not** active, so does not need to be wired.

- ▶ STO2-ENABLE

- If the STO2-ENABLE input is open, no more power is transferred to the motor. The drive becomes torque-free and runs down.

- STO single-channel with safety card PMCprotego S1 or PMCprotego S2:

The input STO2-ENABLE must be connected directly to 24 V. The 2nd shutdown route is not needed.

- STO dual-channel with safety card PMCprotego S1:

The input STO2-ENABLE must be connected to the output STO SIL3 on the safety card.

- If the safety function STO is **not** needed, STO2-ENABLE must be connected directly to 24 V.



INFORMATION

Further information is available in the section entitled "Safety function STO".

4.3.2.3

Digital outputs

Operational readiness (X3B/14, 15)

Functions:

- ▶ The servo amplifier is ready for operation when the relay contact BTB is closed.
- ▶ Operational readiness is not dependent on the ENABLE signal, I²t limitation and braking threshold.
- ▶ If an error occurs, the relay contact opens. The output on the servo amplifier switches off. The output is disabled and supplies no power.
- ▶ A list of error messages is available in the chapter entitled "Messages/Errors", under "Error messages".

Programmable digital outputs DIGITAL-INOUT 1 / 2 (X3A/6, 7)

Functions:

- ▶ Pin 6 and 7 on X3A can either be used as a digital input or output.
- ▶ PLC-compatible (IEC 61131-2, Type 1), 24 VDC, max. 100 mA, volt-free
- ▶ 24 V switching voltage, must be supplied externally.

Setting the parameters:

- ▶ Select whether you wish to use it as an input or output in the commissioning software ("Digital I/O" window).
- ▶ The digital outputs can be used as signal outputs for pre-programmed functions, e.g. "Speed below limit value".
- ▶ A list of the pre-programmed functions is available in the "Digital I/O" window of the commissioning software.
- ▶ If a pre-programmed function has been newly assigned, the data record must be stored in the servo amplifier's EEPROM and the device must be reset (e.g. using the commissioning software PASmotion).

4.3.3 Safety function STO

The safety function STO on the servo amplifier can be triggered by an external safe control system (semiconductor output or positive-guided relay contact) or via the built-in safety card PMCprotego Sx.

4.3.3.1 Safety guidelines

Please note the following safety guidelines:

- ▶ Please note the intended use of the safety function STO (see Chapter entitled "Safety").
- ▶ If the safety function is automatically activated by a control system, you must ensure that the output on the control system is monitored for malfunction. This can avoid a scenario in which the safety function can no longer be activated, e.g. due to a short across the contacts.



WARNING!

Risk to life from the motor running down in an uncontrolled manner!

If the motor runs down in an uncontrolled manner, hazardous situations may arise, which could result in serious injury and death.

Once the safety function STO has been triggered, electrical braking via the drive is no longer possible.

If failsafe braking is required for the drive, an additional mechanical brake must be used.



WARNING!

Risk of electrocution!

The safety function STO does not guarantee electrical isolation from the power output.

Disconnect the servo amplifier from the mains and wait for the intermediate circuit to discharge itself.

4.3.3.2 Signal states

If the safety function STO is not required, 24 VDC must always be connected to the inputs STO1-ENABLE and STO2-ENABLE.

Status conditions of the servo amplifier when using STO1-ENABLE and STO2-ENABLE:

STO1-ENABLE STO2-ENABLE	ENABLE	Message on display	Motor torque
0 V	0 V	-S-	No
0 V	24 V	F27	No
24 V	0 V	Device ID, e.g. P06)	No
24 V	24 V	Device ID, e.g. E06)	Yes

*) with a servo amplifier with 6 A continuous output current

The safety function STO may only be activated once the motor has stopped rotating (setpoint = 0 V, speed = 0 min⁻¹, input ENABLE (X3B/1) = 0 V).

The following sequence **must** be maintained if the drive is to use controlled braking:

1. Controlled braking of the drive (speed setpoint = 0 V)
2. Disable the servo amplifier if speed = 0 min⁻¹ (ENABLE = 0 V)
3. If a suspended load is present, use an additional mechanical measure to block the drive
4. Activate safety function STO (STO1-ENABLE and STO2-ENABLE = 0 V)

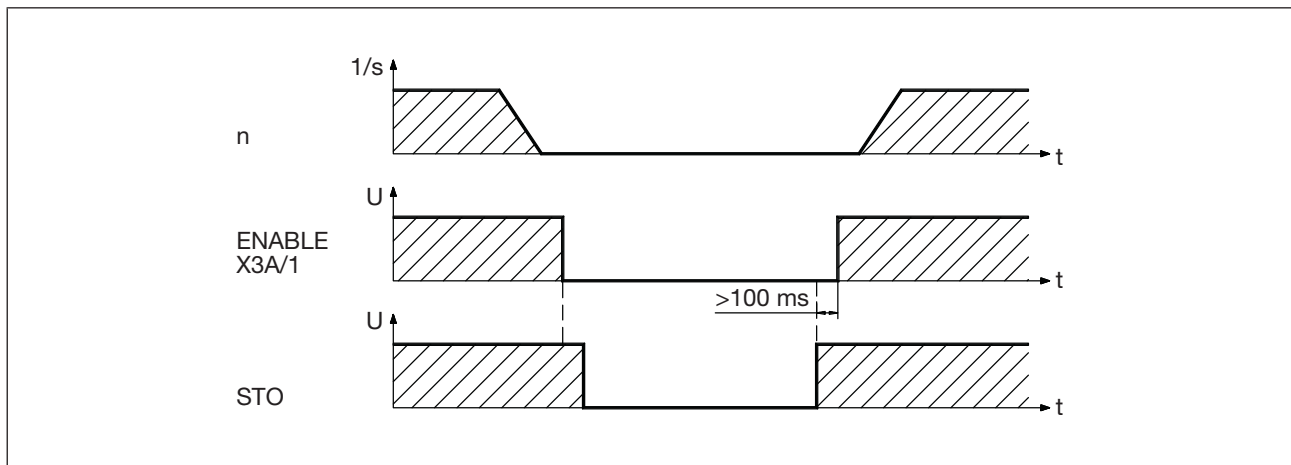

Fig.: Safety function STO

4.3.3.3 Safety function STO without a safety card

Activation of the safety function STO on the servo amplifier can be single or dual-channel.

STO single-channel, without feedback (SIL 2, PL d)

With single-channel activation of the safety function STO, both shutdown routes are switched through one output on a safety relay or safety control system.

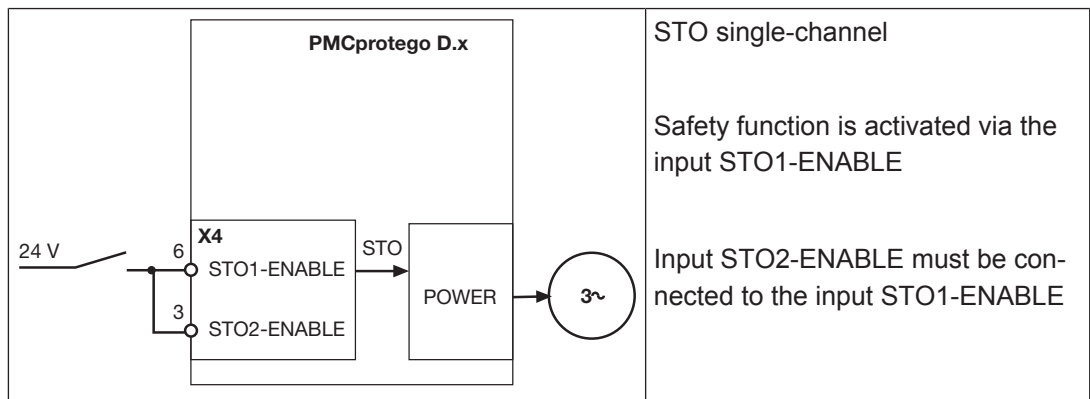

STO dual-channel, with feedback (SIL CL 3, PL e)

With dual-channel activation, both shutdown routes are switched separately. To achieve PL e or SIL CL 3, the safe pulse disabler must be tested periodically to ensure it switches safely, by evaluating the feedback signal from a safety control system.

- ▶ When a plant is started up.
- ▶ On restart after a protection device has been triggered.
- ▶ At least every 8 hours by the operator.

The inputs STO1-ENABLE and STO2-ENABLE are switched alternately in accordance with a defined test sequence. The switch state of the pulse disabler is available at a digital output on the PMCprotego D and is evaluated by a safety control system.

	<p>INFORMATION</p>	<p>The switch state of the pulse disabler is sent to a digital output on the PMCprotego D, e.g. X3A/6, DIGITAL-INOUT1, using the command OxMODE70.</p>
--	---------------------------	--

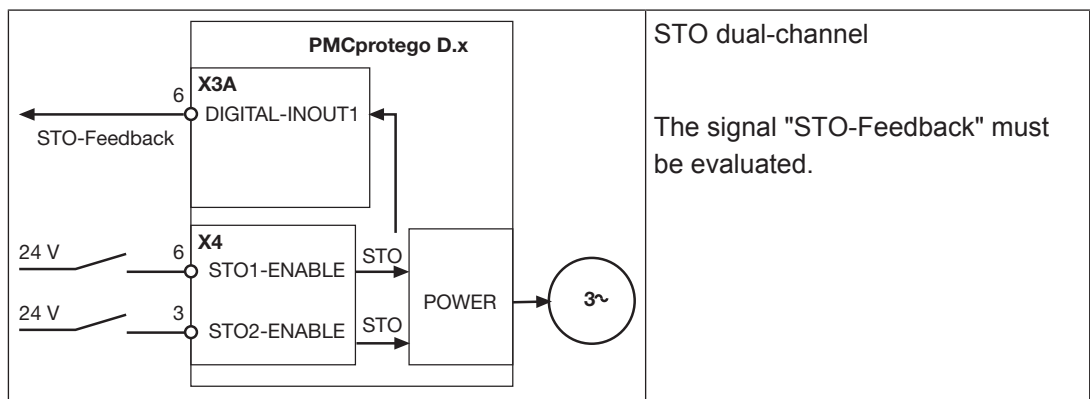

Function test

The test sequence for the function test on the safe pulse disabler must be implemented as shown in the following timing diagram.

Prerequisites for starting the test sequence:

- ▶ Operational readiness BTB/RTO = "1"
- ▶ Enable signal ENABLE = "0"
- ▶ STO1-ENABLE = "0"
- ▶ STO2-ENABLE = "0"

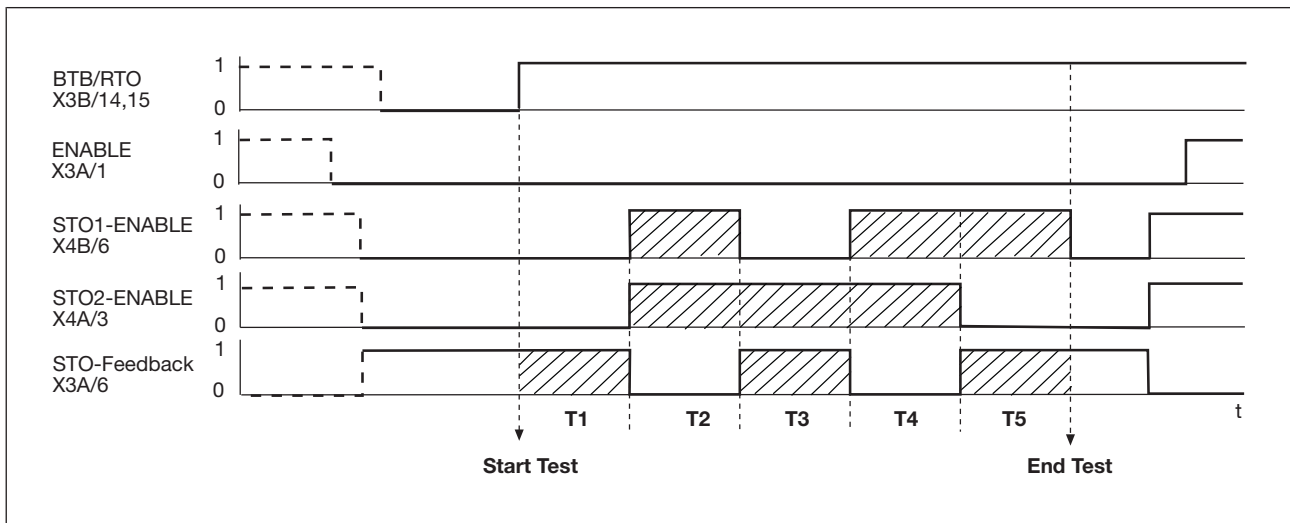

Legend:

- ▶ BTB/RTO: Relay output, operational readiness
- ▶ ENABLE: Digital input, enable signal
- ▶ STO1-ENABLE: Digital input, 1st shutdown route for shutting down the pulse disabler safely
- ▶ STO2-ENABLE: Digital input, 2nd shutdown route for shutting down the pulse disabler safely
- ▶ STO feedback: Digital output, switch state of pulse disabler
- ▶ T1 ... T5: Test sequence
- ▶ Start test: Start of test sequence
- ▶ End test: End of test sequence

ENABLE = "1" can be set after the end of the test sequence.

4.3.3.4 Safety function STO with safety card

With a safety card inserted, activation of the safety function STO can be single or dual-channel.

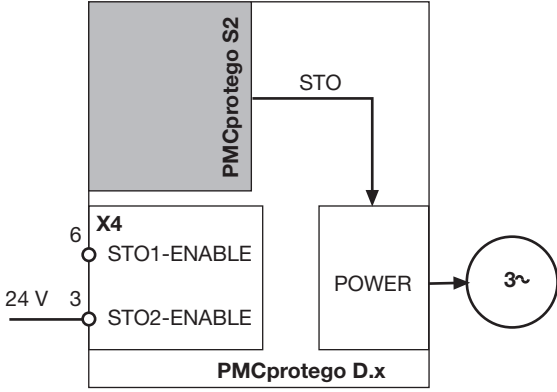
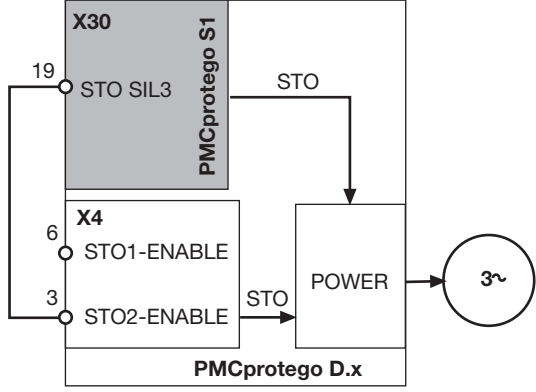
	<p>STO single-channel with safety card PMCprotego S2 (or when the 2nd shutdown route is not used on the safety card PMCprotego S1)</p> <p>Safety function is activated internally via the safety card's STO function.</p> <p>The input STO1-ENABLE has no function.</p> <p>The input STO2-ENABLE must be connected to 24 VDC.</p>
	<p>STO dual-channel with safety card PMCprotego S1</p> <p>Safety function is activated internally via the safety card's STO function and output STO SIL3 on the safety card is connected to STO2-ENABLE as a 2nd shutdown route.</p> <p>The input STO1-ENABLE has no function.</p>

4.3.3.5 Reaction time

The reaction time of the safety function STO, from the falling edge at the inputs STO1-ENABLE and STO2-ENABLE to the removal of power to the motor, is

- ▶ 2 ms on the shutdown route STO1
- ▶ 1 ms on the shutdown route STO2

4.3.3.6 Connection example for STO, single-channel

The following circuit example illustrates single-channel activation of the safety function STO.

- ▶ The drives are switched via a safety gate.
- ▶ Safety gates S1/S2 are monitored by a safety relay PNOZ s3.
- ▶ Shorts across contacts are detected.

- ▶ The safety relay is wired for an automatic reset.
- ▶ The safety function STO complies with PL d (Cat. 2) of EN ISO 13849-1 and SIL CL 2 of EN/IEC 62061.

The relays' wiring must comply with the category or performance level required for the application. Further information on the safety relays is available from Pilz.

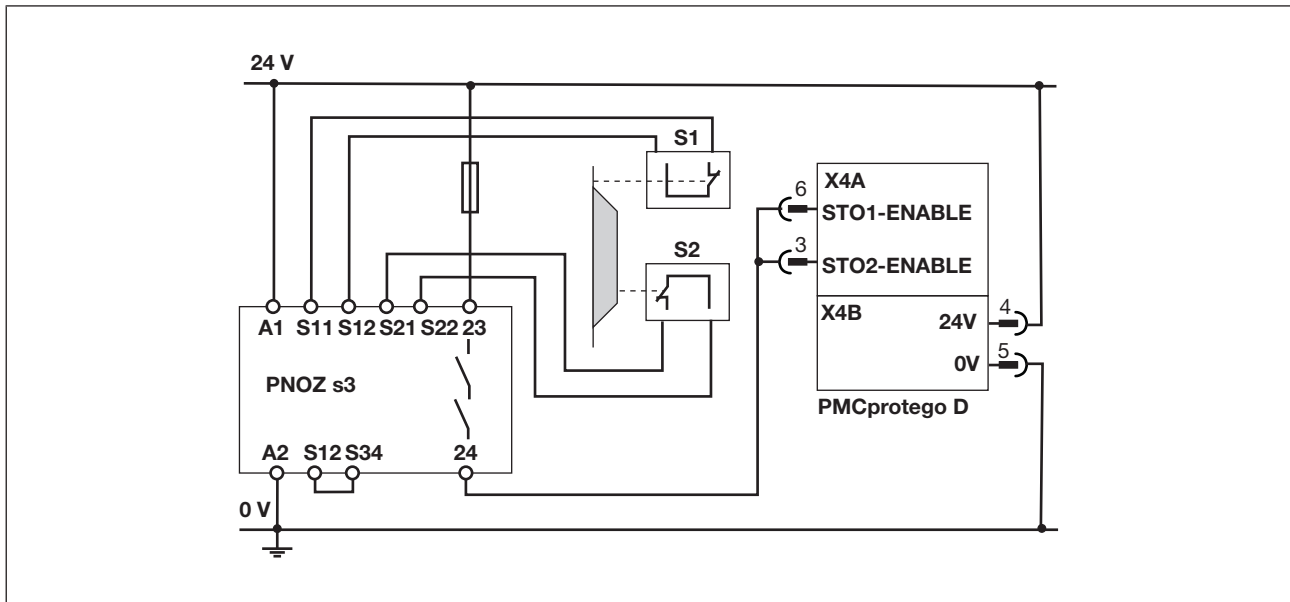

Fig.: STO, single-channel with safety relay PNOZ S3

4.3.3.7 Connection example for STO, dual-channel

The following circuit example illustrates dual-channel activation of the safety function STO.

- ▶ Activation of the inputs STO1-ENABLE and STO2-ENABLE is dual-channel, via the semiconductor outputs from a safety control system PNOZ mm0p.
- ▶ During the periodic test, the state of the pulse disabler is evaluated with the feedback signal DIGITAL-INOUT1.
- ▶ The safety function STO corresponds to PL e (Cat. 4) of EN ISO 13849-1 and SIL CL 3 of EN/IEC 62061.

The relays' wiring must comply with the category or performance level required for the application. Further information on the safety control system PNOZmulti is available from Pilz.

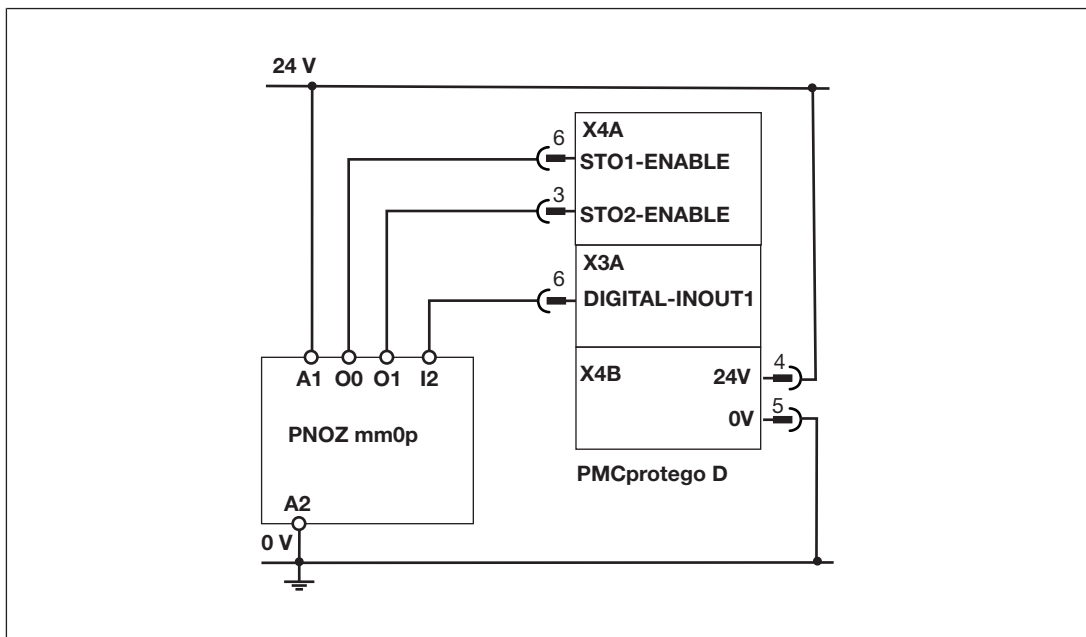

Fig.: STO, dual-channel with the safety control system PNOZ mm0p



INFORMATION

A full application example is available in the application note: "STO in PL e on PMCprotego D with PNOZ mm0p" (see Pilz download area www.pilz.de).

4.3.4 Analogue inputs

Functions:

- ▶ The servo amplifier has 2 analogue voltage inputs (ANALOG-IN1, ANALOG-IN2) for specifying setpoint values.
- ▶ Differential inputs, signal range from -10 VDC to +10 VDC.
- ▶ Resolution (with sign bit): 16 Bit

Setting the parameters:

Parameter settings and additional signal processing can be defined using the commissioning software. The voltage is scalable in current or speed.

- ▶ Default setting:
 - Input ANALOG-IN1: Speed setpoint
 - Input ANALOG-IN2: Torque setpoint
- ▶ If a pre-programmed function has been newly assigned, the data record must be stored in the servo amplifier's EEPROM and the device must be reset (e.g. using the commissioning software PASmotion).

Direction of rotation

- ▶ Default setting: Clockwise rotation of motor shaft (facing the shaft)
 - Positive voltage between terminal X3B/10 (+) and terminal X3B/9 (-)
 - Positive voltage between terminal X3B/12 (+) and terminal X3B/11 (-)

- ▶ Reversing the direction of rotation: Anti-clockwise rotation of motor shaft (facing the shaft):
 - Swap the configuration of terminals X3B/10-9 or X3B/12-11 or change the **Count direction** parameter in the “Feedback” window (0/1).

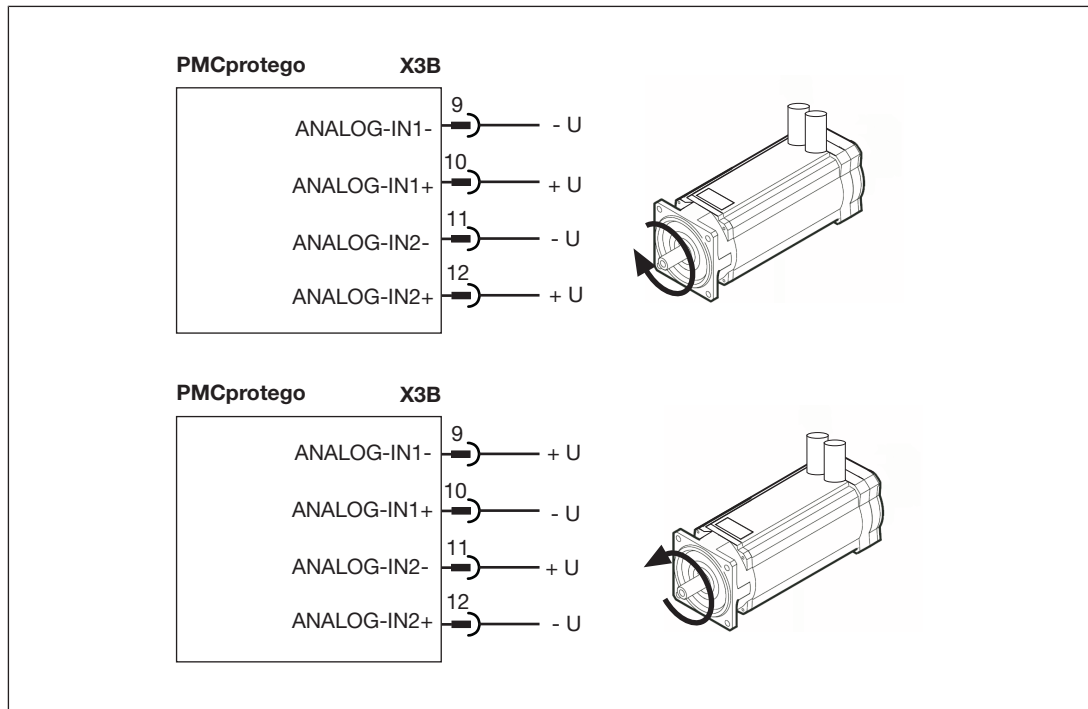

Fig.: Direction of rotation

4.3.5 Encoder systems

4.3.5.1 Overview

Each closed drive system normally requires at least one encoder, which transmits actual values (e.g. speed, position) from the motor to the servo amplifier. Feedback to the servo amplifier can be transmitted in digital or analogue, depending on the encoder type.

Up to three encoders can be used in parallel.

Setting the parameters:

The functions are assigned the following parameters in the commissioning software (PAS-motion):

- ▶ FBTYPE ("Feedback" window), primary feedback in the motor
- ▶ EXTPOS ("Position Loop" window), secondary feedback, external position
- ▶ GEARMODE ("Electronic Gearing" window), secondary feedback, externally driven

Configura- tion	Location	Parameter	Commut- ation	Speed reg- ulator	Position control- ler	Electronic Gearing
One en- coder	In the mo- tor	FBTYPE	x	x	x	
Two en- coders (ex- ternal posi- tion)	In the mo- tor	FBTYPE	x	x		
	External	EXTPOS			x	
Two en- coders (external control)	In the mo- tor	FBTYPE	x	x	x	
	External	GEARMODE				x
Three en- coders (position and control external)	In the mo- tor	FBTYPE	x	x		
	External	EXTPOS			x	
	External	GEARMODE				x

A detailed description of the parameters is available in the commissioning software's online help.

The PMCprotego D supports all standard encoder types.



NOTICE

Select the correct encoder (FBTYPE) in the commissioning software tool

In the commissioning software tool PASmotion you must select the correct encoder (FBTYPE). Selecting the wrong encoder can lead to the destruction of the connected encoder (caused by the wrong supply voltage).

The table below provides an overview of the supported encoder types and their corresponding parameters and connectors.

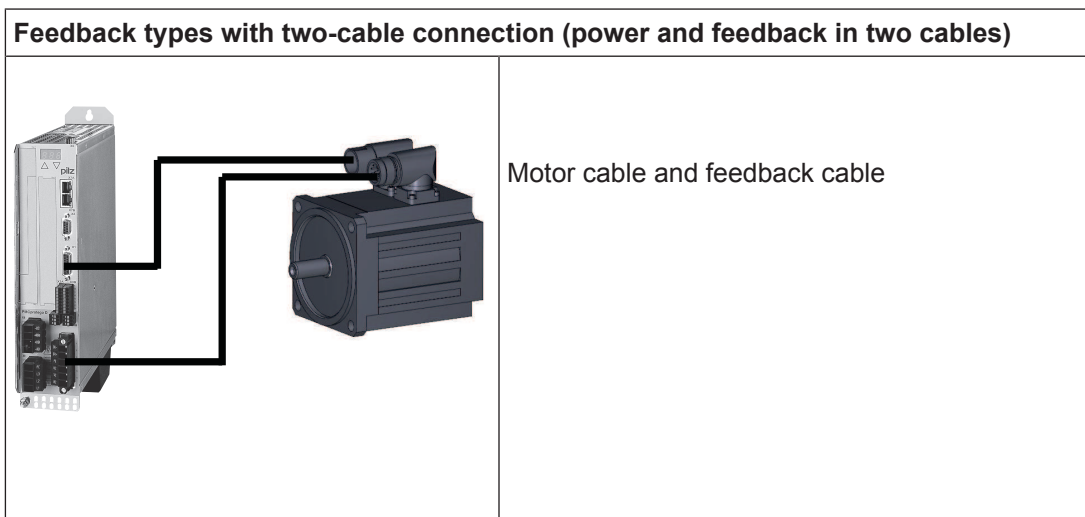
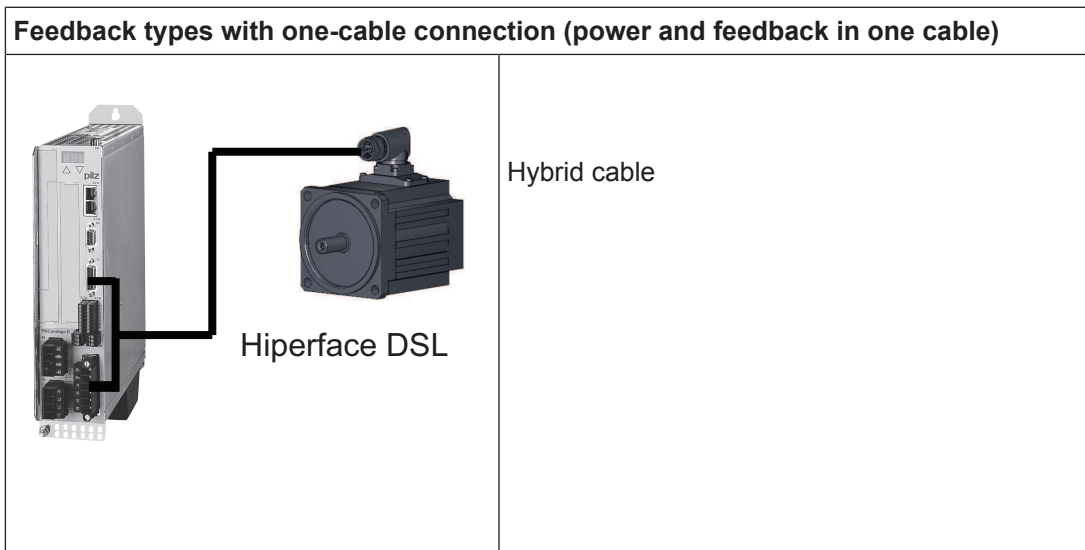

Encoder type	Connector	Parameter FBTYP	Parameter EXTPOS GEARMODE	DC Supply voltage for encoder
Feedback types with one-cable connection (power and feedback in one cable)				
Hiperface DSL	X1	35		7 – 12 V
SFD3	X1	36		7 – 12 V
Feedback types with two-cable connection (power and feedback in two cables)				
Resolver	X2	0	-	-
SinCos encoder with BISS interface, analogue	X1	23, 24	-	5 V
Encoder with BISS interface, digital	X1	20, 22, 33	11, 12	5 V
SinCos encoder with EnDat interface 2.1	X1	4, 21	8	5 V

Encoder type	Connector	Parameter FBTYPE	Parameter EXTPOS GEARMODE	DC Supply voltage for encoder
Encoder with EnDat interface 2.2	X1	32,34	13	5 – 12 V
SinCos encoder with HIPERFACE interface	X1	2	9	7 – 12 V
SinCos encoder with SSI interface	X1	26	-	5 V
SinCos encoder without data track	X1	1, 3, 7, 8	6, 7	5 V
SinCos encoder + Hall encoder	X1	5, 6	-	5 V
Incremental encoder ROD (AquadB) 5 V, with zero pulse 350 kHz	X1	17, 27	10	5 V
Incremental encoder ROD (AquadB) 5 V, without zero pulse 1.5 MHz	X1	30, 31	30	5 V
Incremental encoder ROD (AquadB) 5 V, with zero pulse + Hall encoder	X1	15	-	5 V
Incremental encoder ROD (AquadB) 24 V, without zero pulse	X3	12, 16	2	24 V
Incremental encoder ROD (AquadB) 24 V, without zero pulse + Hall encoder	X3/ X1	14	-	24 V
Absolute encoder with SSI interface	X1	25	25	5 V
Hall encoder	X1	11	-	5 V
Pulse/direction 5 V	X1	-	27	5 V
Pulse/direction 24 V	X3	-	1	24 V
Sensorless (no feedback)	-	10	-	-

Encoder type	Connector	Parameter FBTYPE	Parameter EXTPOS GEARMODE	DC Supply voltage for encoder
Incremental encoder ROD (AquadB) 5 V, with zero pulse	X5	13, 19	3	5 V
Incremental encoder ROD (AquadB) 5 V, with zero pulse + Hall encoder	X5/ X1	18	-	5 V
Absolute encoder with SSI interface	X5	9	5	5 V
SinCos encoder with SSI interface (linear)	X5/ X1	28	-	5 V
Pulse/direction 5 V	X5	-	4	5V

Encoder with expansion card "PosI/O" or "PosI/O-AIO"

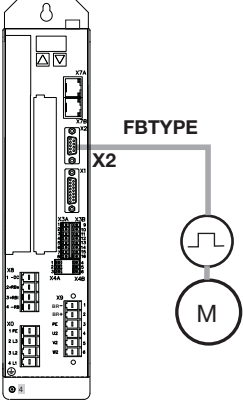
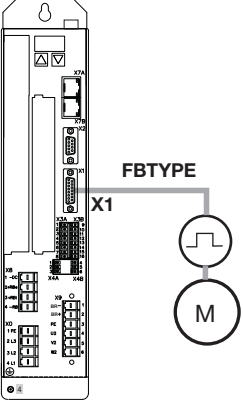
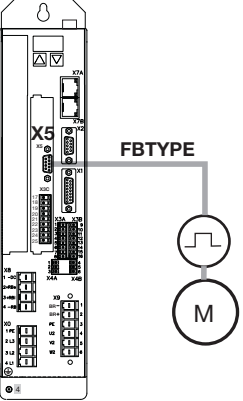
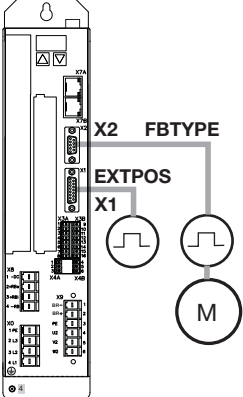
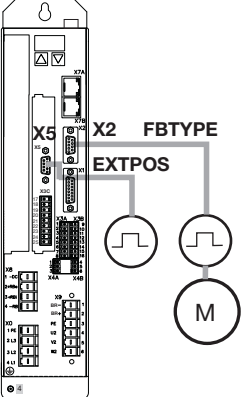
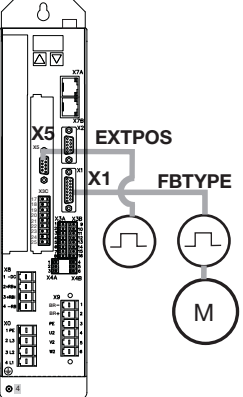
<p>X2: Motor encoder (resolver)</p>	<p>X1: Motor encoder (e.g. incremental encoder)</p>	<p>X5: Expansion card Posl/O, Posl/O-AIO, motor encoder (e.g. incremental encoder)</p>
		
<p>X2: Motor encoder (resolver) X1: External encoder (e.g. incremental encoder)</p>	<p>X2: Motor encoder (resolver) X5: Expansion card Posl/O, Posl/O-AIO, external encoder (e.g. incremental encoder)</p>	<p>X1: Motor encoder (e.g. incremental encoder) X5: Expansion card Posl/O, Posl/O-AIO, external encoder (e.g. incremental encoder)</p>
		

<p>Master-Slave mode X1: Master-Slave connection X2 Master: Motor encoder (resolver) X2 Slave: Motor encoder (resolver)</p>	<p>Master-Slave mode X1 Slave: Motor encoder (e.g. incremental encoder) X2 Master: Motor encoder (resolver) X5 Master, Slave: Expansion card Posl/O, Posl/O-AIO, Master-Slave connection</p>
<p>Master-Slave mode X1 Master: External encoder (e.g. incremental encoder) X1 Slave: Motor encoder (e.g. incremental encoder) X2 Master: Motor encoder (resolver) X5 Master, Slave: Expansion card Posl/O, Posl/O-AIO, Master-Slave connection</p>	<p>Master-Slave mode X1 Master, Slave: Master-Slave connection X2 Master: Motor encoder (resolver) X2 Slave: Motor encoder (resolver) X5 Master: Expansion card Posl/O, Posl/O-AIO, external encoder (e.g. incremental encoder)</p>

4.3.5.2 Resolver

Functions:

- ▶ The resolver determines the absolute position of the rotor to the stator within a revolution and signals this information to the servo amplifier.
- ▶ It is possible to connect resolvers from 2 to 36-poles.

Setting the parameters:

- ▶ Feedback type FBTYPE = 0

4.3.5.3 Encoder

SinCos encoder with HIPERFACE interface (X1)

Functions:

- ▶ SinCos encoder with HIPERFACE interface connected as a primary feedback system
- ▶ Singleturn: resolution of 32768 steps per revolution
- ▶ Multiturn: resolution of 4096 revolutions, each with 32768 steps
- ▶ Programmable position value
- ▶ Process data channel in real-time
- ▶ Suitable as feedback for drive tasks requiring high precision positioning or extremely good synchronisation

Setting the parameters:

Encoder type	Parameter FBTYPE	Parameter EXTPOS	Parameter GEARMODE
HIPERFACE	2	9	9

SinCos encoder with Hall (X1)

Functions:

- ▶ SinCos encoder as a full primary feedback system
- ▶ Cutoff frequency (sin, cos): 350 kHz

Setting the parameters:

Encoder type	Parameter FBTYPE	Parameter EXTPOS	Parameter GEARMODE	Supply voltage Up
SinCos encoder 5 V with Hall	5	-	-	5 V +/- 5%
SinCos encoder 12 V with Hall	6	-	-	7.5 ... 11 V

Encoder with EnDat interface (X1)

Functions:

- ▶ Encoder with EnDat interface connected as a primary or secondary feedback system
- ▶ Single-turn or multi-turn

- ▶ Suitable as feedback for drive tasks requiring high precision positioning or extremely good synchronisation

Setting the parameters:

Encoder type	Parameter FBTYPE	Parameter EXTPOS	Parameter GEARMODE
EnDat 2.1	4	8	8
EnDat 2.1 and wake & shake	21	8	8
EnDat 2.2 (with 5 V)	32	13	13
EnDat 2.2 (with 12 V)	34	13	13

Encoder with BISS interface (X1)

Functions:

- ▶ Encoder with BISS interface connected as a primary feedback system.
- ▶ Single-turn or multi-turn

Setting the parameters:

Encoder type	Parameter FBTYPE	Parameter EXTPOS	Parameter GEARMODE	Supply voltage Up
5 V digital (BISS B)	20	11	11	5 V +/-5%
12 V digital (BISS B)	22	11	11	7.5 – 11 V
5 V digital (BISS C)	33	12	12	5 V +/-5%
12 V analogue (BISS B)	23	-	-	5 V +/-5%
12 V analogue (BISS B)	24	-	-	7.5 – 11 V

SinCos encoder with SSI interface (X1)

Functions:

- ▶ SinCos encoder with SSI interface connected as a linear feedback system

Setting the parameters:

Encoder type	Parameter FBTYPE	Parameter EXTPOS	Parameter GEARMODE
SinCos encoder with SSI interface 5 V	26	-	-

SinCos encoder without data track (X1)

Functions:

- ▶ SinCos encoder without data track connected as a primary or secondary feedback system.
- ▶ Each time the 24 V supply voltage is switched on, the servo amplifier needs the start-up information for the position controller (motor phase parameter MPHASE). Depending on the encoder type, either a wake & shake is executed or the value for the MPHASE parameter is taken from the servo amplifier's EEPROM.

**DANGER!**

Suspended loads! Moving parts present a threat to life.

On vertical axes, the load could fall unbraked. The brake is released with wake & shake and the torque is insufficient to hold the load.

Do not use this feedback system with vertical, suspended loads.

Setting the parameters:

Encoder type	Parameters FBTYPE	Parameters EXTPOS	Parameters GEARMODE	Supply voltage Up	Note
SinCos encoder 5 V	1	6	6	5 V +/-5%	MPHASE from EEPROM
SinCos encoder 12 V	3	7	7	7.5 – 11 V	MPHASE from EEPROM
SinCos encoder 5 V	7	6	6	5 V +/-5%	MPHASE with wake & shake
SinCos encoder 12 V	8	7	7	7.5 – 11 V	MPHASE with wake & shake

4.3.5.4 Incremental encoders

Incremental encoder ROD (AquadB) 5 V, 350 kHz, 1.5 MHz (X1)

Functions:

- ▶ Incremental encoder ROD (AquadB) with 5 V signal connected as a primary or secondary feedback system.
- ▶ Types for cutoff frequency 350 kHz or 1.5 MHz
- ▶ Each time the 24 V supply voltage is switched on, the servo amplifier needs the start-up information for the position controller (motor phase parameter MPHASE). Depending on the encoder type, either a wake & shake is executed or the value for the MPHASE parameter is taken from the servo amplifier's EEPROM.

Setting the parameters:

Encoder type	Parameter FBTYPE	Parameter EXTPOS	Parameter GEARMODE	Note
Incremental encoder 5 V, 350 kHz	27	10	10	MPHASE from EEPROM
Incremental encoder 5 V, 350 kHz	17	10	10	MPHASE with wake & shake
Incremental encoder 5 V, 1.5 MHz	31	30	30	MPHASE from EEPROM
Incremental encoder 5 V, 1.5 MHz	30	30	30	MPHASE with wake & shake

Incremental encoder ROD (AquadB) 5 V, 350 kHz with Hall (X1)

Functions:

- ▶ Incremental encoder ROD (AquadB) with 5 V signal connected as a primary feedback system.
- ▶ Cutoff frequency 350 kHz
- ▶ Temperature monitoring on the motor is connected to X1 and is evaluated there

Setting the parameters:

Encoder type	Parameter FBTYPE	Parameter EXTPOS	Parameter GEARMODE
Incremental encoder 5 V, with zero pulse + Hall en- coder	15	-	-

Incremental encoder ROD (AquadB) 24 V, with Hall (X3, X1)

Functions:

- ▶ Incremental encoder ROD (AquadB) with 24 V signal connected as a primary feedback system.
- ▶ Temperature monitoring on the motor is connected to X1 and is evaluated there
- ▶ Cutoff frequency at X3: 100 kHz
- ▶ Cutoff frequency at X1: 350 kHz

Setting the parameters:

Encoder type	Parameter FBTYPE	Parameter EXTPOS	Parameter GEARMODE
Incremental encoder 5 V, without zero pulse + Hall encoder	14	-	-

Incremental encoder ROD (AquadB) 24 V, without zero pulse (X3)

Functions:

- ▶ Incremental encoder ROD (AquadB) with 24 V signal without zero pulse connected as a primary or secondary feedback system.
- ▶ Connection to the digital inputs DIGITAL-IN1 and DIGITAL-IN2 (X3).
- ▶ Cutoff frequency: 100 kHz, edge steepness: Max. 0.1 μ s
- ▶ Each time the 24 V supply voltage is switched on, the servo amplifier needs the start-up information for the position controller (motor phase parameter MPHASE). Depending on the encoder type, either a wake & shake is executed or the value for the MPHASE parameter is taken from the servo amplifier's EEPROM.

Setting the parameters:

Encoder type	Parameter FBTYPE	Parameter EXTPOS	Parameter GEARMODE	Note
Incremental encoder 24 V, without zero pulse	12	2	2	MPHASE from EE-PROM
Incremental encoder 24 V, without zero pulse	16	2	2	MPHASE with wake & shake



DANGER!

Suspended loads! Moving parts present a threat to life.

On vertical axes, the load could fall unbraked. The brake is released with wake & shake and the torque is insufficient to hold the load.

Do not use this feedback system with vertical, suspended loads.

4.3.5.5 Absolute encoder with SSI interface

Functions:

- ▶ Multi-turn absolute encoder with SSI interface connected as a primary or secondary feedback system
- ▶ Binary or gray code
- ▶ Cutoff frequency: 1.5 MHz
- ▶ Resolution per revolution: Max. 16 Bit
- ▶ Revolutions: Max. 16 Bit
- ▶ Motor temperature monitoring

Setting the parameters:

Encoder type	Parameter FBTYPE	Parameter EXTPOS	Parameter GEARMODE
Absolute encoder with SSI interface	25	25	25

4.3.5.6 Hall encoder

Hall encoder (X1)

Functions:

- ▶ Connection of a Hall encoder as the primary feedback system
- ▶ Cutoff frequency: 350 kHz

Setting the parameters:

Encoder type	Parameter FBTYPE	Parameter EXTPOS	Parameter GEARMODE
Hall encoder	11	-	-

4.3.6 Electronic gearing, Master-Slave mode

Functions:

- ▶ With electronic gearing, multiple axes are synchronised through software in the servo amplifier.
- ▶ The servo amplifier is controlled as a slave by an external, secondary encoder.
- ▶ You can build up master/slave systems or use an external encoder as a setpoint encoder.

Setting the parameters:

- ▶ Parameters for the servo amplifier are set using the commissioning software (PASmotion) (electronic gearing):
 - Number of pulses and revolutions
 - Reduction and transmission gear ratios



INFORMATION

Type and source of danger

If you are not using the supply voltage at X1 and are connecting the encoders to the X1 terminal, please note:

- Change Bit 20 of the ASCII command DRVCNFG2 (see ASCII Object Reference in the commissioning software's online help). Otherwise error F04 will be registered.

The following types may be used as external encoders for the reference signal:

Encoder type	Connector	Parameter GEARMODE
Encoder with BISS interface, digital	X1	11, 12
SinCos encoder with EnDat 2.1 interface	X1	8
Encoder with EnDat 2.2 interface	X1	13
SinCos encoder with HIPERFACE interface	X1	9
SinCos encoder without data track	X1	6, 7
Incremental encoder (AquadB) 5 V, 350 kHz	X1	10
Incremental encoder (AquadB) 5 V, 1.5 MHz	X1	30
Incremental encoder (AquadB) 24 V, 100 kHz	X3	2
Absolute encoder with SSI interface 5 V	X1	25
Pulse/direction 5 V	X1	27
Pulse/direction 24 V	X3	1

When using the expansion card Pos I/O or PosI/O-AIO:

Encoder type	Con- nector	Parameter GEARMODE
SSI 5 V	X5	5
Incremental encoder (AquadB) 5 V	X5	3
Pulse/direction 5 V	X5	4

4.3.6.1 Stepper motor control systems (pulse/direction)

Functions:

- ▶ You can connect the servo amplifier to a vendor-neutral stepper motor control system.
- ▶ Signal level 5 V or 24 V
- ▶ Parameters for the servo amplifier are set using the commissioning software (electronic gearing). The number of steps is selectable. As a result, the servo amplifier can be adapted to the pulse/direction signals of any stepper motor control system.



INFORMATION

Use an incremental encoder to achieve higher EMC immunity.

Parameter setting:

Control	Parameter GEARMODE
Pulse/direction 5 V (X1)	27
Pulse/direction 24 V (X3)	1

4.3.6.2 Master-Slave mode

Functions:

- ▶ Interconnection of 2 PMCprotego D
- ▶ Slave is activated by the Master via the encoder interface X1

Example of Master-Slave mode for 2 PMCprotego D:

Parameter setting:

Emulation	Master Parameter ENCMODE	Slave Parameter GEARMODE
Incremental encoder	9	30
SSI	10	25

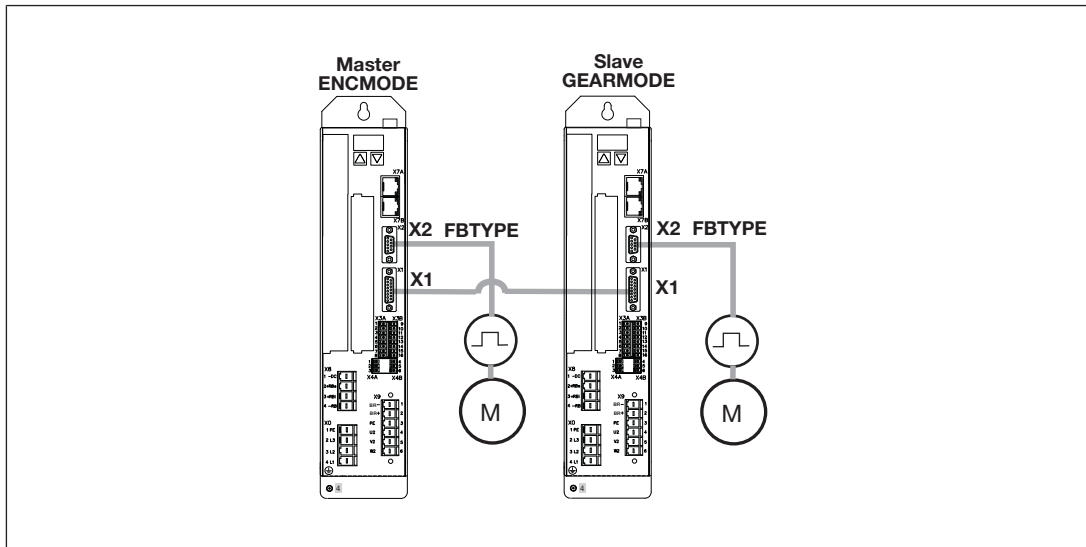

Fig.: Master-Slave mode via X1

**INFORMATION**

On the expansion cards PosI/O or PosI/O-AIO there are no terminating resistors in terminal X5. At X5, up to 16 Slaves can be connected to a Master (see "Expansion card PosI/O, PosI/O-AIO").

4.3.7**Encoder emulation**

Output signals for additional devices are generated from signals from the resolver or a SinCos encoder, e.g. for control systems or PMCprotego D. The position of the motor shaft is calculated in the servo amplifier from the cyclical-absolute signals from the resolver or SinCos encoder:

- ▶ Signals are incremental encoder compatible
- ▶ Signals for the SSI interface

Output of incremental encoder signals:

Functions:

With this encoder emulation, a total of six tracks are generated from the existing output signals from the resolver or SinCos encoder; a higher level control system uses these tracks for positioning. These six tracks are track A, B and NI (zero pulse) and their inverted signals A \bar , B \bar and NI \bar .

Setting the parameters:

The following can be set in the "Encoder Emulation" window in the commissioning software:

- ▶ Position of the zero pulse within one mechanical revolution (NI-OFFSET parameter)
- ▶ Resolution (before multiplication) in counts/revolution
- ▶ Default count direction: Upwards (facing the motor axis when rotating clockwise)

Parameter ENCMODE	Encoder type FBTYPE	Resolution	Zero pulse
9 = Incremental encoder => X1	0 = Resolver	32 ... 4096 ($2^8 \dots 2^{12}$)	One per revolution (only when $A = B = 1$)
	>0 = SinCos encoder etc.	256 ... 524288 ($2^8 \dots 2^{19}$)	

**INFORMATION**

Binary resolutions (2^x) can be used if a safety card is built in.

Timing diagram for the incremental encoder signal:

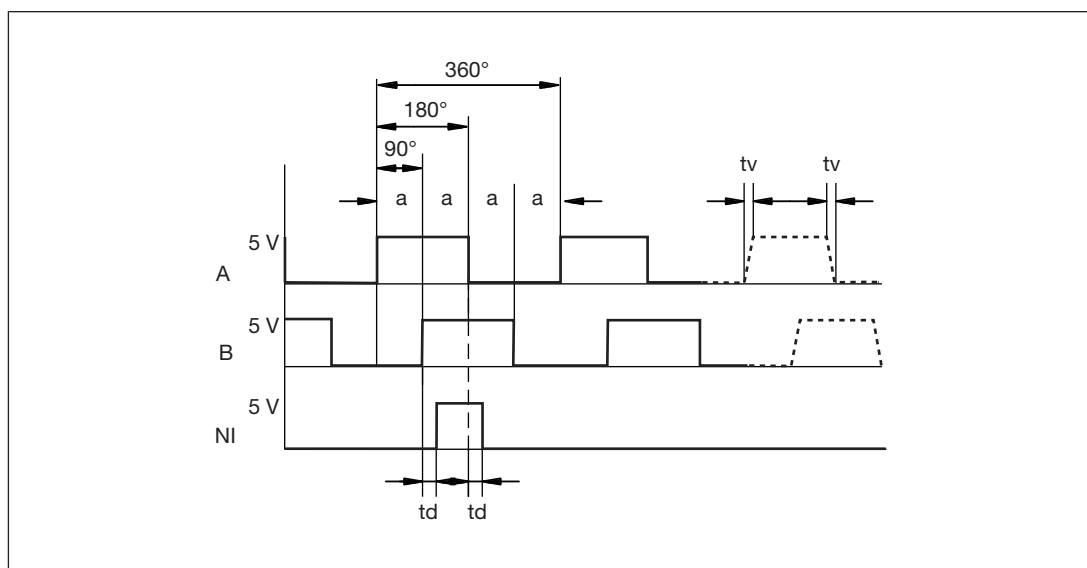

- ▶ a: Edge spacing $\geq 0.2 \mu\text{s}$
- ▶ tv: Edge steepness $\leq 0.1 \mu\text{s}$
- ▶ NI – td: Delay $\leq 0.1 \mu\text{s}$
- ▶ $|\Delta U| \geq 2 \text{ V}/20 \text{ mA}$
- ▶ Default count direction: Upwards, facing the motor axis when rotating clockwise

Output of SSI signals

Functions:

With this encoder emulation, positional data for the SSI interface is prepared from the existing output signals from the resolver or SinCos encoder.

- ▶ A max. 32 Bits are transferred.
- ▶ Singleturn: The leading 12 to 16 Bits are zero, the following 16 Bits indicate the position. On 2-pole resolvers the position value refers to a full revolution of the motor; on 4-pole resolvers it refers to half a revolution and on 6-pole resolvers to one third of a revolution.
- ▶ Multiturn: The leading 12 to 16 Bits indicate the number of revolutions; the following 16 bits state the position.

Revolution																
	SSIREVOL															
Bit																
	15	14	13	12	11	10	9	8	7	6	5	4	3	2	1	0
		14	13	12	11	10	9	8	7	6	5	4	3	2	1	0
			13	12	11	10	9	8	7	6	5	4	3	2	1	0
				12	11	10	9	8	7	6	5	4	3	2	1	0
				11	10	9	8	7	6	5	4	3	2	1	0	

Position																
Bit	15	14	13	12	11	10	9	8	7	6	5	4	3	2	1	0

Setting the parameters:

The following can be set in the “Encoder Emulation” window in the commissioning software:

- ▶ Output of SSI signals, "Encoder Emulation" window:
ENCMODE = 10
- ▶ Clock frequency of the SSI evaluation (1.3 μs or 10 μs)
- ▶ Signal sequence in gray format (standard) or binary format

Timing diagram:

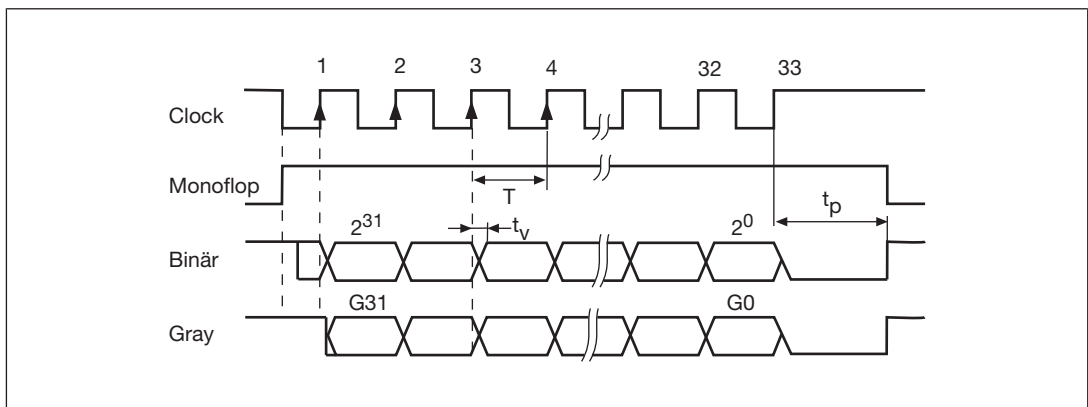

Fig.: Timing diagram in gray and binary code

- ▶ Switch over time for data $t_v \leq 300 \text{ ns}$
- ▶ Min. period length $T = 600 \text{ ns}$
- ▶ Timeout $t_p = 1.3 \mu\text{s}$ or $10 \mu\text{s}$ (SSITOUT parameter)
- ▶ Output $|\Delta U|$
- ▶ $I \geq 2 \text{ V}/20 \text{ mA}$
- ▶ Input $|\Delta U| \geq 0.3 \text{ V}$
- ▶ Default count direction: Upwards, facing the motor axis when rotating clockwise

4.3.8 Communications interfaces

4.3.8.1 RS232 interface

The servo amplifier has an RS232 interface with minimum configuration (TxD, RxD, GND):

- ▶ Using the commissioning software, you can use the RS232 interface to set the following parameters on a PC:
 - Operating parameters
 - Position control parameters
 - Motion block parameters
- ▶ The interface is selected and set-up in the commissioning software.

For further information please refer to the chapter entitled "Wiring".

4.3.8.2 CANopen interface

The servo amplifier has a CANopen interface for connection to a bus system:

The interface uses the following profiles:

- ▶ CANopen communication profile, specification CiA DS-301
- ▶ Device profile for drives DS-402

The following functions are available for position controllers, for example:

- ▶ Jogging with variable speed
- ▶ Reference runs
- ▶ Start motion task
- ▶ Start direct motion task
- ▶ Specify digital setpoint
- ▶ Data transfer functions

For further information please refer to the CANopen manual.

When the appropriate parameters are set, the analogue setpoint inputs can still be used.

4.3.8.3 Ethernet-based interface

The servo amplifier operates as an Ethernet subscriber. The connection to Ethernet is made via the two 8-pin RJ45 sockets.

Communication is via:

- ▶ EtherCAT

See [Type code](#)  17]

The interface is deactivated if a fieldbus expansion card is inserted.

The protocol installed with the firmware must be enabled (ASCII command ETHMODE).

Default setting:

CANopen is activated if a CANopen connection is detected when booting the servo amplifier. Otherwise, EtherCAT is activated.

Various operating and fault statuses are displayed via the LEDs on the two RJ45 interfaces.

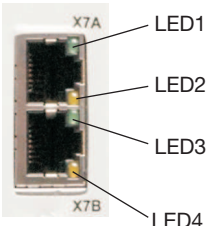
RJ45	LED	Name	Signal	Meaning
	LED1	LINK_IN	On	Receipt is valid (IN port)
			Off	Invalid, power off or reset
	LED2	CYCLIC	On	Network cyclical
			Flashes	Network not cyclical
			Off	Power off or reset
	LED3	LINK_OUT	On	Receipt is valid (OUT port)
			Off	Invalid, power off or reset
	LED4	REPEATER	On	Repeater on, network cyclical
			Flashes	Repeater on, network not cyclical
			Off	Repeater off, power off or reset

Recommended cable: Cat 5e

4.3.9 SD card

The top of the servo amplifier contains a card slot for an SD card. The memory card is used to download the firmware and parameter sets to the servo amplifier.

Using the SD card you can quickly and easily commission an exchanged device or identical axes on series machines.

The SD card must be formatted with a FAT32 file system. An appropriate SD card is available as an accessory (see Order reference for accessories).

Maximum storage capacity of the SD card: 2 GB



DANGER!

Only insert or remove the memory card when the servo amplifier is switched off.

Carry out a reference run if you are using an absolute encoder or have read in new parameters.

4.3.10 Tools

- ▶ The commissioning software adapts the operating parameters of the PMCprotego D to the motor and the machine's conditions. The commissioning software runs on a personal computer (PC).
It provides support when commissioning the servo amplifier and can control the drive directly through service functions. You can change the parameters and immediately see the effect on the drive.
- ▶ The commissioning software contains an oscilloscope, which reads and displays actual values from the servo amplifier.
The oscilloscope function enables all the control parameters (current, speed and position controllers) to be optimised quickly and simply.

- ▶ The safety functions to be carried out by the safety card are defined in the Configurator PASconfig SDrive:
 - Configuration of the safety functions
 - Setting of limit values, braking ramps for the safety functions, monitoring of motion sequences
- ▶ A database containing motor parameters for Pilz motors makes it easier to set parameters for the servo amplifier.
If the correct motor-related data has been loaded from the database, the control parameters generally only need to be optimised.

**INFORMATION**

Detailed information can be found in the following documents:

- Software manual and online help for the commissioning software.
- PMCprimo programming manual

Both documents are available on the Internet.

4.4 Expansion cards

4.4.1 Expansion card PMCprotego S1-2, PMCprotego S2-2

The expansion cards PMCprotego S1-2 and PMCprotego S2-2 are available as accessories (see [Type code](#)  17).

The safety card monitors safety functions in accordance with EN 61800-5-2. It monitors safe motion sequences on drives, which are safely brought to a stop and shut down in the event of an error.

The safety card is built into a servo amplifier PMCprotego D. This converts the servo amplifier into a safe servo amplifier.

**INFORMATION**

Detailed information about the function range can be found in the operating manuals for the PMCprotego S1-2 and PMCprotego S2-2.

4.4.2 Expansion card I/O-14/08

The expansion card I/O-14/08 is available as an accessory.

Functions:

- ▶ 14 additional digital inputs and 8 digital outputs
- ▶ The function of the inputs and outputs can be configured in the commissioning software.
- ▶ The inputs initiate the motion tasks that are stored in the servo amplifier.
- ▶ The outputs signal the status of the integrated position controller to the higher level control system.

- ▶ The functions of the inputs and outputs correspond to the functions that can be assigned to the digital inputs and outputs on connector X3 of the servo amplifier.
- ▶ The inputs and outputs are isolated from the servo amplifier through optocouplers.



Fig.: Front view of expansion card I/O-14/08

LEDs:

LED	Description
Green	24 V supply voltage is present
Red	Fault on the expansion card's outputs (overload and/or short circuit)

Enter the motion block number (example)

Motion block number	A7	A6	A5	A4	A3	A2	A1	A0
Binary 1010 1110	1	0	1	0	1	1	1	0
Decimal 174	128	-	32	-	8	4	2	-

The functions can be configured in the commissioning software. The table overleaf shows the default settings.

Pin	Input/output	Default setting	Description
1	On	A0	Motion block number, LSB
2	On	A1	Motion block number, 2 ¹
3	On	A2	Motion block number, 2 ²
4	On	A3	Motion block number, 2 ³
5	On	A4	Motion block number, 2 ⁴
6	On	A5	Motion block number, 2 ⁵
7	On	A6	Motion block number, 2 ⁶
8	On	A7	Motion block number, MSB
9	On	Reference	Polls the reference switch. The input is not evaluated if a digital input is used as the reference input on the base unit.
10	On	S_fehl_clear	Clears the warning for drag error (n03)/reaction monitoring (n04)
11	On	FStart_Folge	The motion task defined in the motion block is started with the setting "Start via I/O". The next motion task cannot start until the current motion block has reached its target position.

Pin	Input/output	Default setting	Description
12	On	FStart_Tipp x	Starts the "Jog mode" for set-up. "x" is the speed stored in the servo amplifier for the jog mode function. A rising edge starts the motion; a falling edge stops the motion.

Connector X11A

Pin	Input/output	Default setting	Description
1	On	FRestart	Continues the motion task that was previously stopped.
2	On	FStart_I/O	Starts the motion task that is addressed via the inputs A0 ... A7 (connector X11A/1...8).
3	Off	InPosition	When a motion task reaches its target position (in the "In-Position" window), the output registers a high signal. An open circuit will not be detected.
4	Off	Folge-InPos	The start of each motion task within an automatic sequence of motion tasks is signalled by the inversion of the output signal. When the first motion task is initiated, the output registers a low signal. The message may be varied via the parameters.
		PosReg 0	May only be set via commands
5	Off	S_fehl	The output registers a low signal when it leaves the preset drag error window.
6	Off	PosReg1	Default: Software limit switch 1, output registers a high signal
7	Off	PosReg2	Default: Software limit switch 2, output registers a high signal
8	Off	PosReg3	May only be set via parameters
9	Off	PosReg4	May only be set via parameters
10	Off	PosReg5	May only be set via parameters
11	-	24 VDC	Supply voltage for digital outputs
12	-	I/O-GND	Earth for the digital signals from the control system

Connector X11B

4.4.3 Expansion card PosI/O, PosI/O-AIO

The expansion card PosI/O, PosI/O-AIO is available as an accessory.

This expansion card has fast, bidirectional, digital 5 V inputs and outputs. The functionality of the inputs and outputs can be set in the commissioning software, e.g.:

- ▶ Encoder emulation (output of incremental encoder or SSI compatible signals)
- ▶ Input for fast RS 485 signals (5 V, encoder control, Master-Slave)

The expansion card PosI/O-AIO also has 2 analogue inputs and 2 analogue outputs (monitor outputs). The functions can be set in the commissioning software.

**INFORMATION**

A maximum of one expansion card PosI/O or PosI/O-AIO may be used in a PMCprotego D.

4.4.3.1 Incremental encoder ROD (AquadB) 5V, (X5, X1)

Functions:

- ▶ Incremental encoder ROD (AquadB) with 5 V signal connected as a primary or secondary feedback system.
- ▶ The encoder's supply voltage and temperature monitoring for the motor are connected to the amplifier via X1.
- ▶ Cutoff frequency (A, B, N): 1.5 MHz
- ▶ Each time the 24 V supply voltage is switched on, the servo amplifier needs the start-up information for the position controller (motor phase parameter MPHASE). Depending on the encoder type, either a wake & shake is executed or the value for the MPHASE parameter is taken from the servo amplifier's EEPROM.

Setting the parameters:

Encoder type	Parameter FBTYPE	Parameter EXTPOS/GEARMODE	Parameter ENCMODE	Note
Incremental encoder ROD 5 V	13	3	0	MPHASE from EEPROM
Incremental encoder ROD 5 V	19	3	0	MPHASE with wake & shake

**DANGER!**

Suspended loads! Moving parts present a threat to life.

On vertical axes, the load could fall unbraked. The brake is released with wake & shake. The torque is insufficient to hold the load.

Do not use this feedback system with vertical, suspended loads.

Incremental encoder ROD (AquadB) 5 V, with Hall (X5, X1)

Functions:

- ▶ Incremental encoder ROD (AquadB) with 5 V signal and Hall encoder connected as a primary feedback system.
- ▶ The encoder's supply voltage and temperature monitoring for the motor are connected to the amplifier via X1.
- ▶ Cutoff frequency at X5: 1.5 MHz
- ▶ Cutoff frequency at X1: 350 kHz

Setting the parameters:

Encoder type	Parameter FBTYPE	Parameter EXTPOS	Parameter GEARMODE	Parameter ENCMODE
Incremental encoder ROD 5 V, with Hall	18	-	-	0

4.4.3.2 Absolute encoder with SSI interface (X5, X1)

Functions:

- ▶ Synchronous, serial absolute encoder connected as a primary or secondary feedback system. It is possible to read binary and grey data formats.
- ▶ The encoder's supply voltage and temperature monitoring for the motor are connected to the amplifier via X1.
- ▶ Cutoff frequency: 1.5 MHz

Setting the parameters:

Encoder type	Parameter FBTYPE	Parameter EXTPOS	Parameter GEARMODE	Parameter ENCMODE
Absolute encoder with SSI interface	9	5	5	0

4.4.3.3 SinCos encoder with SSI interface (X5, X1)

Functions:

- ▶ SinCos encoders with SSI interface connected as a linear feedback system.
- ▶ Cutoff frequency (sin, cos): 350 kHz
- ▶ The voltage supply for the encoder and temperature monitoring on the motor are connected to X1 and is evaluated there

Setting the parameters:

Encoder type	Parameter FBTYPE	Parameter EXTPOS	Parameter GEARMODE	Parameter ENCMODE
SinCos encoder with SSI interface 5 V linear	28	-	-	0

4.4.3.4 Electronic gearing, Master-Slave mode

The expansion card can be used to implement:

- ▶ Electronic gearing in Master-Slave mode
- ▶ Connection to a stepper motor control system with 5 V signal

Electronic gearing, Master-Slave mode

Functions:

- ▶ Max. 17 servo amplifiers can be interconnected
- ▶ Max. 16 servo amplifiers can be activated by a Master as Slaves
- ▶ Connection to terminal X5
- ▶ Cutoff frequency: 1.5 MHz

Setting the parameters:

- ▶ Setting for Master: Output of position at terminal X5 in the "Encoder Emulation" window
- ▶ Setting for Slave: In the "Electronic gearing" window (GEARMODE)

Emulation	Parameter for Slave GEARMODE	Parameter for Master ENCMODE
Incremental encoder ROD	3	1
SSI	5	2

Connection to a stepper motor control system with 5 V signal

Function:

- ▶ Connection of the servo amplifier to a stepper motor control system with 5 V signal
- ▶ Connection to terminal X5
- ▶ Cutoff frequency: 1.5 MHz

Setting the parameters:

Encoder type	FTYPE	EXTPOS	GEARMODE
Pulse/direction 5 V	---	---	4

4.4.3.5

Encoder emulation

The Pos/O-Monitor expansion card is required for encoder emulation. Output signals for a higher level position controller are generated from signals from the resolver or a SinCos encoder. The position of the motor shaft is calculated in the servo amplifier from the cyclical-absolute signals from the resolver or SinCos encoder:

- ▶ Signals are incremental encoder compatible
- ▶ Signals for the SSI interface

Output of incremental encoder signals

Functions:

With this encoder emulation, a total of six tracks are generated from the existing output signals from the resolver or SinCos encoder; a higher level control system uses these tracks for positioning. These six tracks are track A, B and NI (zero pulse) and their inverted signals A\, B\ and NI\.

Setting the parameters:

The following can be set in the "Encoder Emulation" window in the commissioning software:

- ▶ Position of the zero pulse within one mechanical revolution (NI-OFFSET parameter)
- ▶ Resolution (before multiplication) in counts/revolution
- ▶ ENCMODE = 1: Incremental encoder compatible signals from the resolver or SinCos encoder
- ▶ ENCMODE = 3: Encoder signal from X1 is available at X5

Parameter ENCMODE	Encoder type	Resolution	Zero pulse
1 = incremental encoder	Resolver	256 ... 4096 ($2^8 \dots 2^{12}$)	One per revolution (only when $A = B = 1$)
	SinCos encoder	256 ... 524288 ($2^8 \dots 2^{19}$)	One per revolution (only when $A = B = 1$)
3 = Incremental encoder interpolation	SinCos encoder	4 ... 256 ($2^2 \dots 2^7$) TTL counts * resolution of encoder	Encoder signal passed from X1 to X5

Timing diagram for the incremental encoder signal:

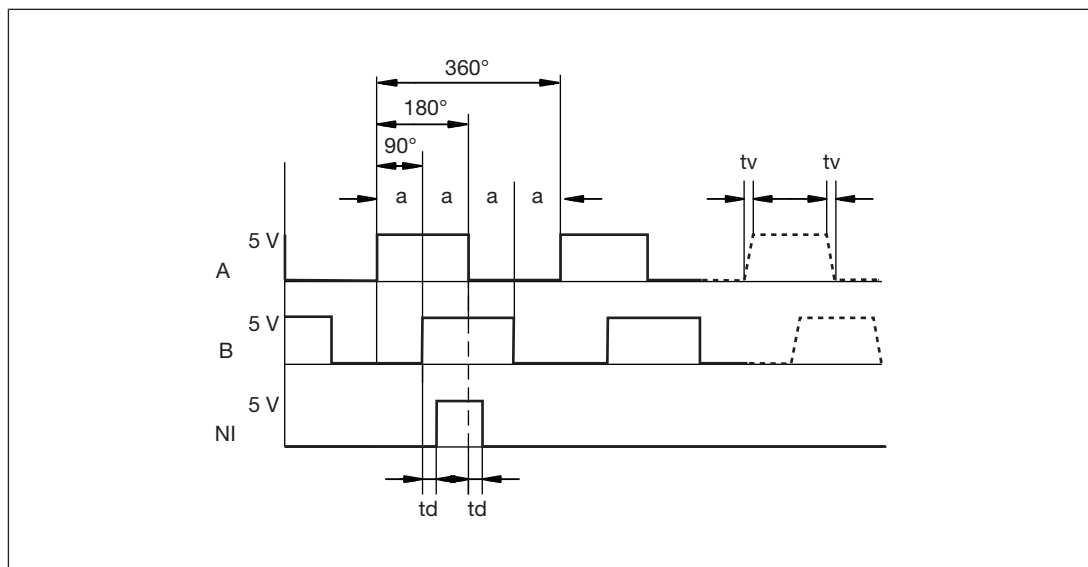

- ▶ a: Edge spacing $\geq 0.2 \mu\text{s}$
- ▶ tv: Edge steepness $\leq 0.1 \mu\text{s}$
- ▶ NI – td: Delay $\leq 0.1 \mu\text{s}$
- ▶ $|\Delta U| \geq 2 \text{ V}/20 \text{ mA}$
- ▶ Default count direction: Upwards, facing the motor axis when rotating clockwise

Output of SSI signals

Functions:

With this encoder emulation, positional data for the SSI interface is prepared from the existing output signals from the resolver or SinCos encoder.

- ▶ A max. 32 Bits are transferred.
- ▶ Singleturn: The leading 12 to 16 Bits are zero, the following 16 Bits indicate the position. On 2-pole resolvers the position value refers to a full revolution of the motor; on 4-pole resolvers it refers to half a revolution and on 6-pole resolvers to one third of a revolution.
- ▶ Multiturn: The leading 12 to 16 Bits indicate the number of revolutions; the following 16 bits state the position.

Revolution																
	SSIREVOL															
Bit																
	15	14	13	12	11	10	9	8	7	6	5	4	3	2	1	0
		14	13	12	11	10	9	8	7	6	5	4	3	2	1	0
			13	12	11	10	9	8	7	6	5	4	3	2	1	0
				12	11	10	9	8	7	6	5	4	3	2	1	0
				11	10	9	8	7	6	5	4	3	2	1	0	

Position																
Bit	15	14	13	12	11	10	9	8	7	6	5	4	3	2	1	0

Setting the parameters:

The following can be set in the “Encoder Emulation” window in the commissioning software:

- ▶ Clock frequency of the SSI evaluation (1.3 μs or 10 μs)
- ▶ Signal sequence in grey format (standard) or binary format

Timing diagram:

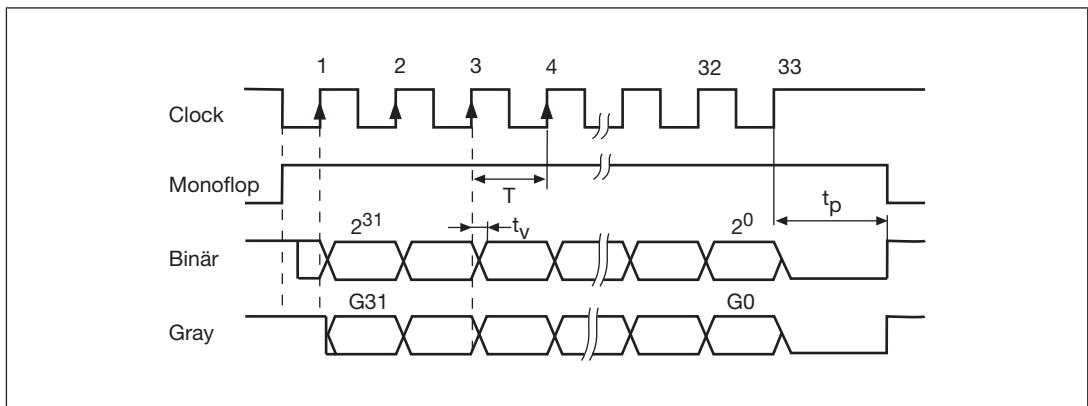

Fig.: Timing diagram in gray and binary code

- ▶ Switch over time for data $t_v \leq 300 \text{ ns}$
- ▶ Min. period length $T = 600 \text{ ns}$
- ▶ Timeout $t_p = 1.3 \mu\text{s}$ or $10 \mu\text{s}$ (SSITOUT parameter)
- ▶ Output $|\Delta U|$
- ▶ $I \geq 2 \text{ V}/20 \text{ mA}$
- ▶ Input $|\Delta U| \geq 0.3 \text{ V}$
- ▶ Default count direction: Upwards, facing the motor axis when rotating clockwise

4.4.3.6 Analogue outputs

Functions:

- ▶ The expansion card PosI/O-AIO has 2 analogue voltage outputs (ANALOG-OUT1, ANALOG-OUT2). Digital measured values recorded in the servo amplifier can be output.
- ▶ Signal range from -10 VDC to +10 VDC.
- ▶ Resolution (with sign bit): 16 Bit

Setting the parameters:

- ▶ A list of the pre-programmed functions is available in the "Digital I/O" window of the commissioning software.
- ▶ If a pre-programmed function has been newly assigned, the data record must be stored in the servo amplifier's EEPROM and the device must be reset (e.g. using the commissioning software PASmotion).

4.4.3.7 Analogue inputs

Functions:

- ▶ The expansion card PosI/O-AIO has 2 analogue voltage inputs (ANALOG-IN3, ANALOG-IN4) for specifying setpoint values.
- ▶ Differential inputs, signal range from -10 VDC to +10 VDC.
- ▶ Resolution (with sign bit): 16 Bit

Setting the parameters:

- ▶ A list of the pre-programmed functions is available in the "Digital I/O" window of the commissioning software.
- ▶ If a pre-programmed function has been newly assigned, the data record must be stored in the servo amplifier's EEPROM and the device must be reset (e.g. using the commissioning software PASmotion).

4.4.4 PROFIBUS DP interface expansion card

The PROFIBUS DP expansion card is available as an accessory.

Information about the function range and software protocol is available in the "Operating manual PROFIBUS DP for PMCtendo DD and PMCprotego D".

The expansion card has two PROFIBUS DP interfaces. They are wired in parallel on two female 9-pin D-Sub connectors.

The servo amplifier supplies the voltage to the expansion card.

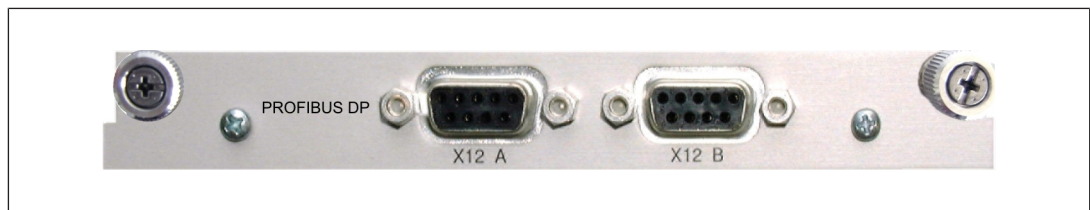

Fig.: Front view of the PROFIBUS DP expansion card

4.4.5 Expansion card PROFINET



INFORMATION

For information on the PROFINET expansion card, please refer to the operating manual "PROFINET for PMCtendo DD5 and PMCprotego D".

4.4.6 Expansion card Fan Controller

With the built-in fan controller, noise emissions are reduced. The expansion card must be specified when the servo amplifier is ordered. It cannot be retrofitted and is only available on request.

The expansion card is built into either slot 2 or 3 (see [Type code \[17\]](#)).



INFORMATION

An expansion card can be used in slot 1 if the fan controller is built into slot 2. **No** expansion cards can be used if the fan controller is built into slot 3.

Function

The fan switches on and off, depending on the ambient temperature, the heat sink temperature or the brake power. In average temperature or performance ranges, the fan runs at 50 % of its rated speed. This reduces the noise emission considerably.

Monitoring	Fan off	Fan approx. 50 %	Fan on
Ambient temperature	< 55 °C	Approx. 58 °C	> 65 °C
Heat sink temperature	< 60 °C	Approx. 65 °C	> 75 °C
Brake resistor (internal)	< 20 W	Approx. 30 W	> 45 W

4.5 Switch on/switch off behaviour

This section describes the behaviour of the servo amplifier when switching on and off. It explains the measures that are required to achieve compliance with the standards when a stop or E-STOP is performed during operation.



INFORMATION

The servo amplifier's 24 VDC supply must be maintained even after a stop or emergency stop.

The parameters ACTFAULT (reaction to fault) and STOPMODE (reaction to ENABLE signal) define how the drive behaves when it is switched off.

ACTFAULT/STOPMODE	Behaviour*
0	Motor runs down in an uncontrolled manner
1 (default)	Motor is braked in a controlled manner

*) please refer also to the ASCII object reference in the commissioning software's online help

Behaviour during a power failure

The servo amplifier detects the failure of one or more input phases.

The behaviour of the servo amplifier is set using the commissioning software: In the "Basic Setup" window, under "Response to Loss of Input Phase", select (PMODE):

- ▶ A **warning** appears if the higher level control system is intended to bring the drive to a standstill:
A message indicates that an input phase is missing (message "n05") and the motor current is limited to 4 A. The servo amplifier is not switched off. The higher level control system can now either end the current cycle specifically or bring the drive to a standstill. The error message "NETZ-BTB, F16", for example, is sent to a digital output on the servo amplifier and is evaluated by the control system.
- ▶ An **error message** appears if the servo amplifier is intended to bring the drive to a standstill:
A missing input phase is registered as an **error** (error message "F-19"). The servo amplifier is switched off; the BTB relay contact for operational readiness opens. If the factory default setting is unchanged (ACTFAULT=1), the motor is braked using the set emergency braking ramp.

Behaviour when the undervoltage threshold is reached

The value of the undervoltage threshold will depend on the type of servo amplifier. If the actual value drops below the undervoltage threshold in the intermediate circuit, error "F05" (undervoltage) is displayed. The reaction of the drive depends on the setting made for the parameters ACTFAULT and STOPMODE.

Behaviour when the "holding brake" function is enabled

Servo amplifiers on which the "holding brake" function has been enabled have a separate procedure to switch off the inverted rectifier. The removal of the ENABLE signal initiates electrical braking.

A potential malfunction of the holding brake must be considered. Bringing a motor to a standstill safely using the holding brake requires an additional electromechanical N/O contact for the holding device and a suppression device for the brake.

Behaviour of the safety function STO

The safety function STO activates the pulse disabler on the servo amplifier and removes the power to the motor.

4.5.1 Normal mode

The behaviour of the servo amplifier always depends on the current setting of various parameters (e.g. ACTFAULT, VBUSMIN, VELO, STOPMODE, see commissioning software's online help).

The diagram below illustrates the correct functional sequence when switching the servo amplifier on and off.

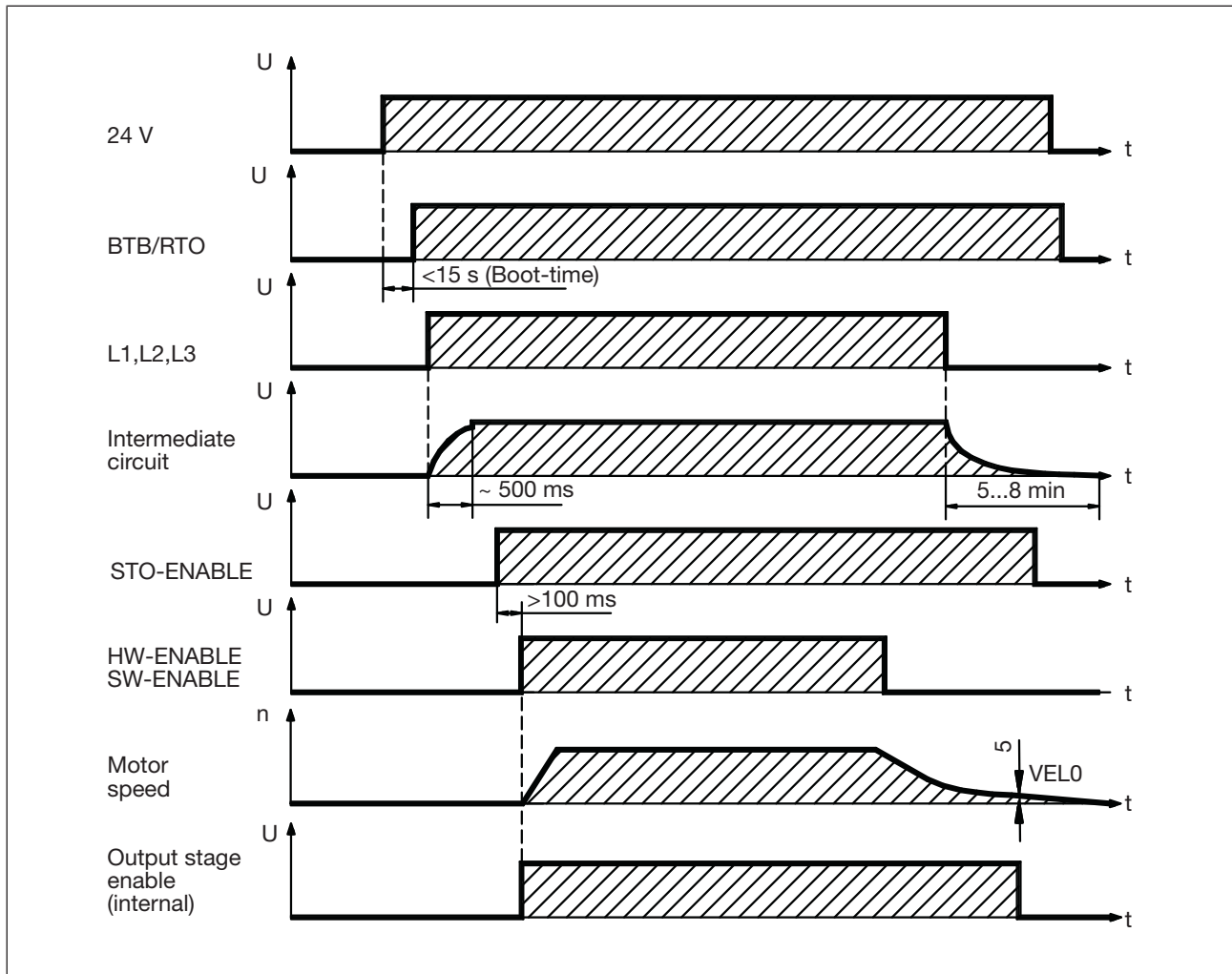

Fig.: Switching on and off under normal conditions

Servo amplifiers on which the "Holding brake" function has been enabled have a separate procedure to switch off the inverted rectifier (see section in this chapter entitled "Motor holding brake").

The drive is shut down safely using the safety function STO.



NOTICE

Please note the following when using a safety card PMCprotego S: Before setting the servo amplifier enable, the "Ready" output on the safety card (X30/16) must be polled!

4.5.2 Fault condition

The behaviour of the servo amplifier always depends on the current setting of various parameters (e.g. ACTFAULT, VBUSMIN, VEL0, STOPMODE, see commissioning software's online help).



DANGER!

Risk to life from the motor running down in an uncontrolled manner!

With some errors, the output stage switches off immediately, irrespective of the setting on the parameter ACTFAULT. If the motor runs down in an uncontrolled manner, hazardous situations may arise, which could result in serious injury and death.

Once the safety function STO has been triggered, electrical braking via the drive is no longer possible.

If failsafe braking is required for the drive, an additional mechanical brake must be used.

The diagram illustrates the start-up procedure and the sequence of the servo amplifier's internal control system if the motor temperature is exceeded when the default parameters are set. The error F06 does not switch off the output stage immediately. Controlled braking is initiated when ACTFAULT = 1.

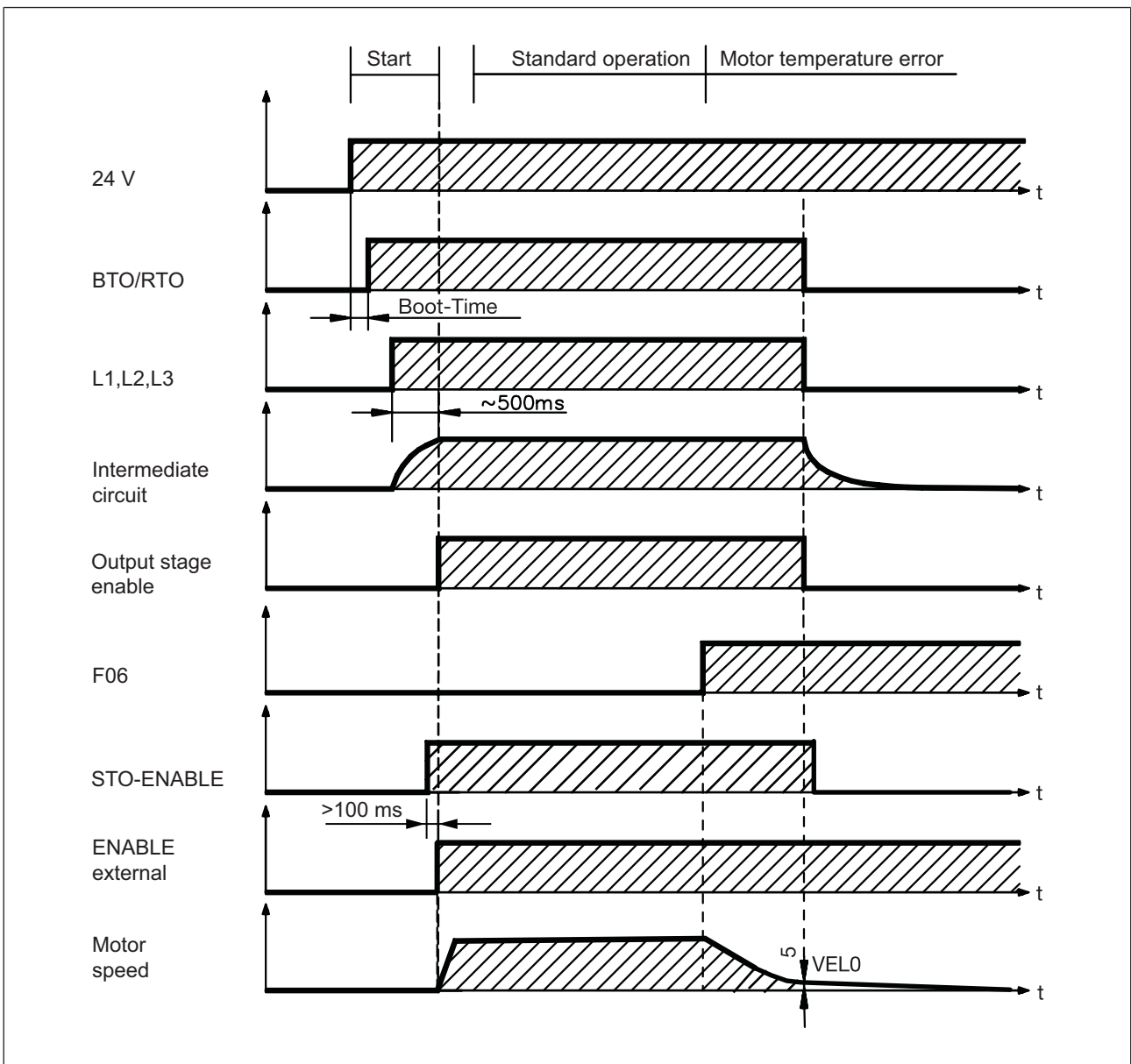

Fig.: Switching on and off under fault conditions

Even if there is no intervention from an external control system (in this example, the ENABLE signal remains active), the motor is immediately braked using the emergency braking ramp if an input phase fault is detected and the factory default setting is unchanged (ACT-FAULT = 1).



NOTICE

Please note the following when using a safety card PMCprotego S: Before setting the servo amplifier enable, the "Ready" output on the safety card (X30/16) must be polled!

4.6 Implementation of stop categories

The control functions stop, emergency stop, and emergency switching off are defined in the standard EN 60204. Details for the safety-related aspects of this function can be found in the standards ISO13849 and IEC 62061 (for further information see [Stop, emergency stop and emergency off functions](#)  27]).

Stop

The stop function stops the drive in normal operation. The stop function is defined in the standard EN 60204.

The stop category must be determined from a risk assessment of the machine.

- ▶ Stop functions must have priority over assigned start functions.
- ▶ It must be possible to trigger stops of category 0 and category 1 independently of the operating mode; the stop category 0 must have priority.
- ▶ If necessary, measures have to be taken to connect safety devices and interlocks.
- ▶ If necessary, the stop function must signal its status to the control logic.
- ▶ A reset of the stop function must not lead to a hazardous situation.

4.6.1 Stop Category 0

Stopping by immediate removal of power to the machine actuators (this is an uncontrolled stop).

With the safety function STO (Safe Torque Off) the drive can be stopped safely with the internal electronics of the servo amplifier. The safety function STO is described in the following chapter [Safety function STO](#)  22].

4.6.2 Stop Category 1

A controlled stop, with power to the machine actuators available to perform the braking. The power to the motor is interrupted (switched off or pulse disable), when standstill is achieved.

Drive-integrated solution

The **safety card PMCprotego S from Pilz** is used to implement a controlled stop of stop category 1. The safety function "Safe stop 1 – SS1" must be activated then. Information on the safety card PMCprotego S is available in the download area www.pilz.com.

As an alternative, the stop category 1 can be implemented via the control function with auxiliary contactors, as described in the following example.

Circuit example emergency stop with stop category 1

Stopping the motor in accordance with Category 1 is performed by removal of power and controlled, electronic braking (STOPMODE and ACTFAULT parameters set to "1"). The 24 V supply voltage to the servo amplifier must be maintained.

- ▶ The drive is braked in a controlled manner as it comes to a stop (disable). If the speed VEL0 (see timing diagram in the section entitled "Switch on/switch off behaviour") drops below the set value, the holding brake is applied and the servo amplifier is shut down.

The mains supply and the holding brake are galvanically isolated after the two periods set separately on the timers have elapsed.

**NOTICE**

If there is an internal fault on the servo amplifier, the motor is forcibly braked once K20 drops out. Make sure that the machine cannot be damaged by abrupt braking. Frequent forced braking using the holding brake built into the motor can damage the brake.

Wiring suggestion with external wiring

Implementation with stop category 1 emergency stop,

Control function with auxiliary contactors, without safety card PMCprotego S from Pilz.

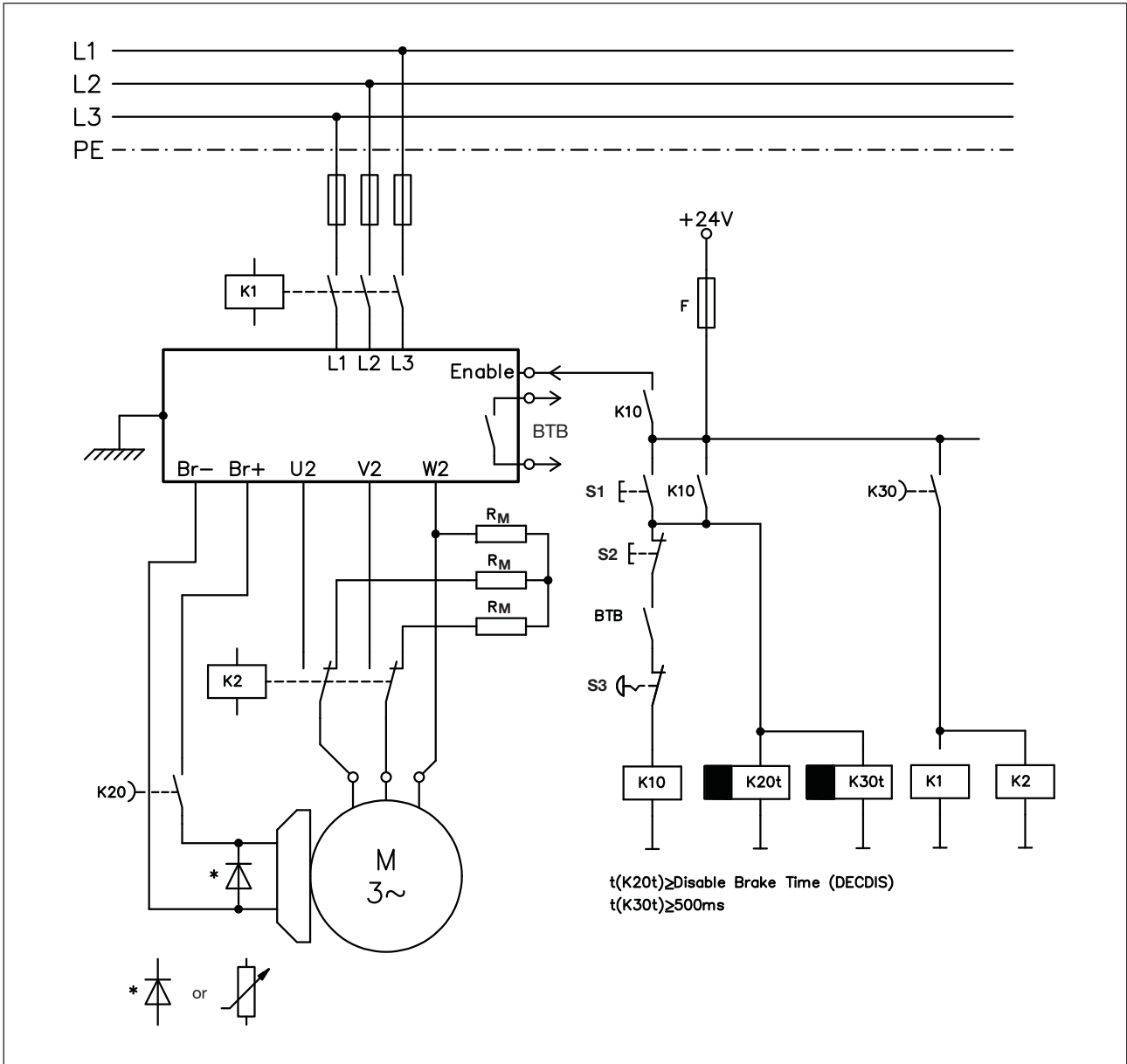

Fig.: Stop category 1

- ▶ S1: On
- ▶ S2: Off
- ▶ S3: E-STOP

Motor output P_M	Motor circuit brake resistor R_M
Up to 2.5 kW	27 Ω (20 W) 1000 V
2.5 kW - 5 kW	8.2 Ω (50 W) 1000 V
5 kW - 10 kW	2.7 Ω (110 W) 1000 V
10 kW - 20 kW	1 Ω (300 W) 1000 V

Motor output P_M	Motor circuit brake resistor R_M
20 kW - 40 kW	0.33 Ω (600 W) 1000 V

$$P_M = (M_0 \cdot n_n) / 9550$$

where:

- ▶ P_M : Motor output [kW]
- ▶ M_0 : Standstill torque [Nm]
- ▶ n_n : Rated speed [1/min]

4.6.3 Stop Category 2

A controlled stop, with power left available to the machine actuators.

Drive-integrated solution

The **safety card PMCprotego S from Pilz** is used to implement a controlled stop of stop category 2. The safety function "Safe stop 2 – SS2" (Safe Stop 2) must be activated then. Information on the safety card PMCprotego S is available in the download area www.pilz.com.

As an alternative, the stop category 2 can be implemented via the control function with auxiliary contactors, as described in the following example.

Circuit example emergency stop with stop category 2

The machine receives the operational stop command (disable) and brakes the drive using the set braking ramp (STOPMODE and ACTFAULT parameters set to "1").

- ▶ The drive is braked in a controlled manner as it comes to a stop. If the speed VELO (see timing diagram in the section entitled "Switch on/switch off behaviour") drops below the set value, the holding brake is applied and the servo amplifier is shut down. In this case, the mains voltage is maintained.
- ▶ If the mains is switched off, not only is a controlled braking procedure initiated but the mains voltage is galvanically isolated from the holding brake after a delay, which can be set on the timer.

Wiring suggestion with external wiring

Implementation with category 2 emergency stop,

Control function with auxiliary contactors, without safety card PMCprotego S from Pilz.

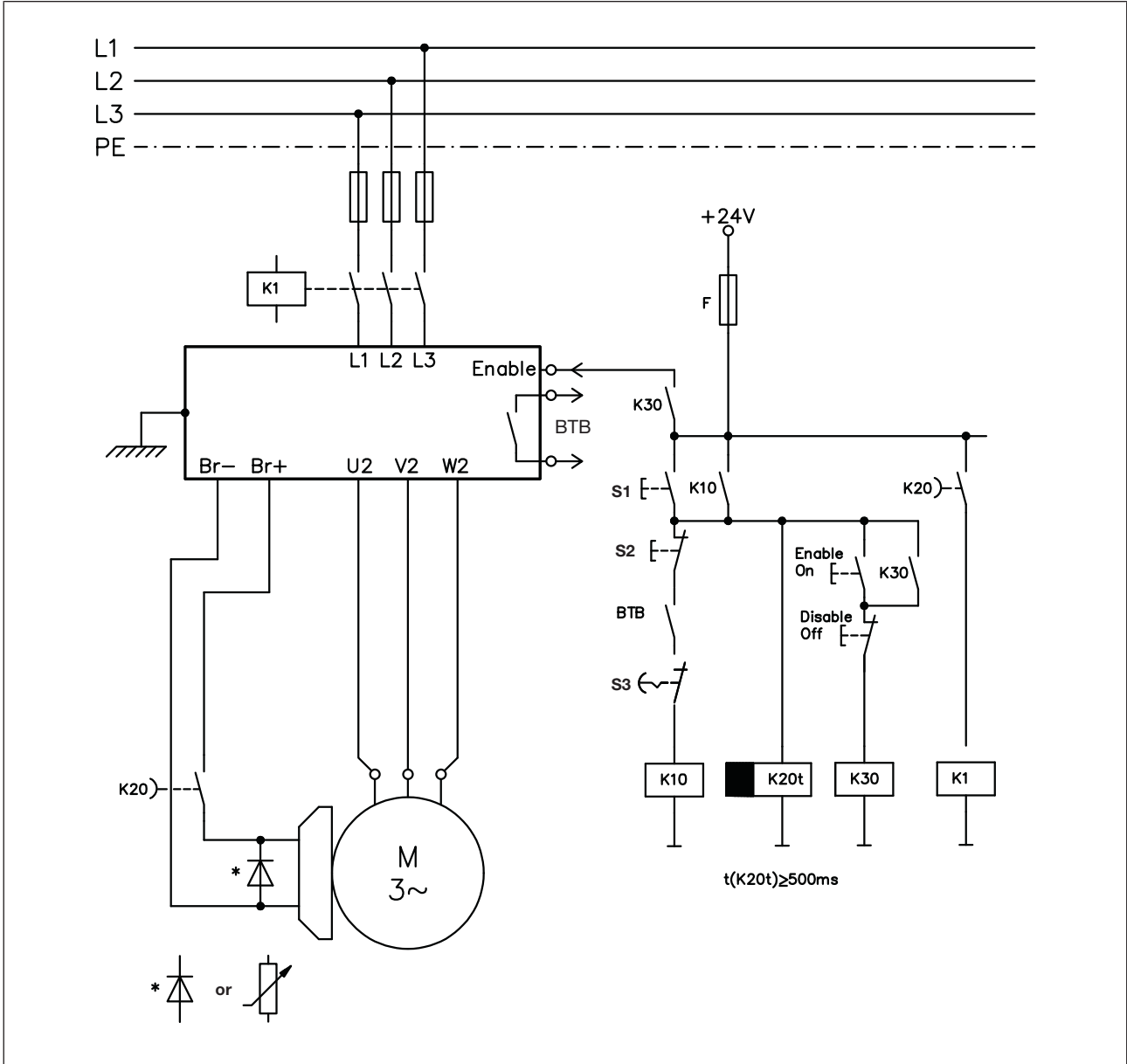

Fig.: Stop category 2

- ▶ S1: On
- ▶ S2: Off
- ▶ S3: E-STOP

Motor output P _M	Motor circuit brake resistor R _M
Up to 2.5 kW	27 Ω (20 W) 1000 V
2.5 kW - 5 kW	8.2 Ω (50 W) 1000 V
5 kW - 10 kW	2.7 Ω (110 W) 1000 V
10 kW - 20 kW	1 Ω (300 W) 1000 V

Motor output P_M	Motor circuit brake resistor R_M
20 kW - 40 kW	0.33 Ω (600 W) 1000 V

$$P_M = (M_0 * n_n) / 9550$$

where:

- ▶ P_M : Motor output [kW]
- ▶ M_0 : Standstill torque [Nm]
- ▶ n_n : Rated speed [1/min]

5 Installation

5.1 General requirements

Mounting location

- ▶ The servo amplifier should be installed in an enclosure, e.g. control cabinet, that conforms to the protection class required for the environment.
- ▶ The mounting location must be free from conductive and aggressive materials.
- ▶ Make sure you keep the necessary space clear above and below the servo amplifier (see section entitled "Installing the servo amplifier")

Ambient conditions

- ▶ When installing the system in an enclosure such as a control cabinet, the environmental data for the servo amplifier must be taken into account. Details are available in the chapter entitled "Technical Details".
- ▶ Protect the servo amplifier from undue stress. In particular, do not allow any components to become bent and/or insulation distances to be modified during transportation and handling.
- ▶ Make sure there is an adequate flow of cool, filtered air from the bottom of the control cabinet or use a heat exchanger. Please note the ambient temperature of **0 - 40 °C** with nominal data, **40 - 55 °C** with power derating **2.5 %/K**.
- ▶ In extreme ambient conditions, additional measures such as control cabinet air conditioning may be required in order to keep within the prescribed limit values.

Earthing, EMC

- ▶ Make sure that the servo amplifier and motor are earthed correctly. Do not use varnished (non-conductive) mounting plates.
- ▶ Components that generate magnetic fields should not be installed directly next to the servo amplifier. If necessary, shield the magnetic fields.
- ▶ Damage due to electrostatic discharge!
Electrostatic discharge can damage components. Ensure discharge before touching the servo amplifier, e.g. by touching an earthed, conductive surface or by wearing an earthed armband.

Power supply

- ▶ The servo amplifier and power supply should be installed close to each other on the conductive, **earthed** mounting plate inside the control cabinet.

Control cabinet lighting

- ▶ Use low interference panel lighting for inside the control cabinet.

5.2 Dimensions

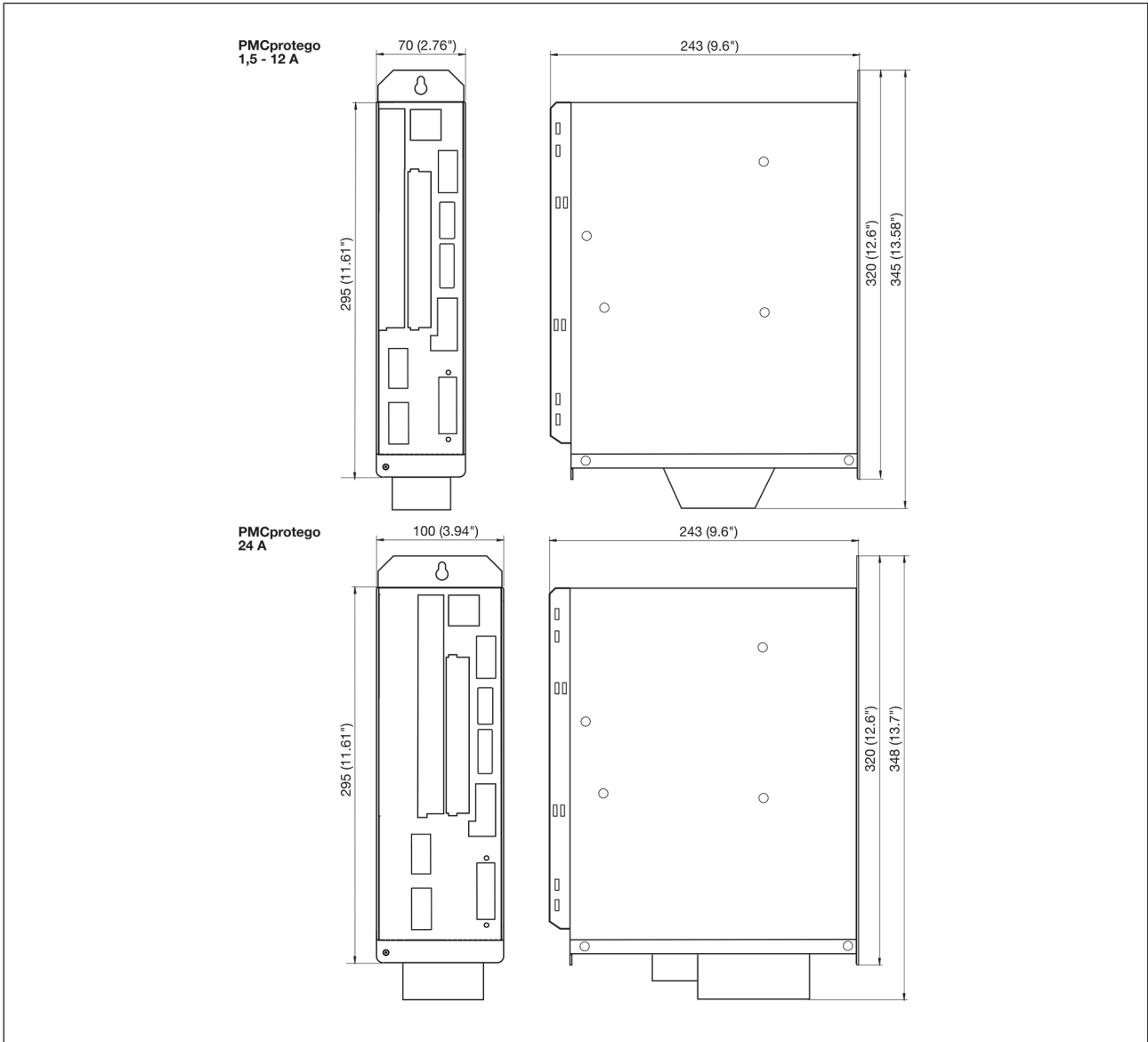

Fig.: Dimensions of the PMCprotego D, stated in mm (")

5.3 Installing the servo amplifier

- ▶ Installation materials: 3 hexagon socket cylinder head screws DIN 912, M5
- ▶ Required tool: Hexagonal wrench 4 mm



INFORMATION

Remove the fan before installing the servo amplifier.

Re-attach the fan once the device is installed. See section entitled: "Installing and removing the fan".

Proceed as follows:

- ▶ Drill M5 holes in the control cabinet's mounting plate, as shown in the illustrations.
- ▶ Remove the fan underneath the servo amplifier (see section in this chapter entitled: "Installing and removing the fan").
- ▶ Attach the servo amplifier to the mounting plate in your control cabinet.
- ▶ Replace the fan underneath the servo amplifier.

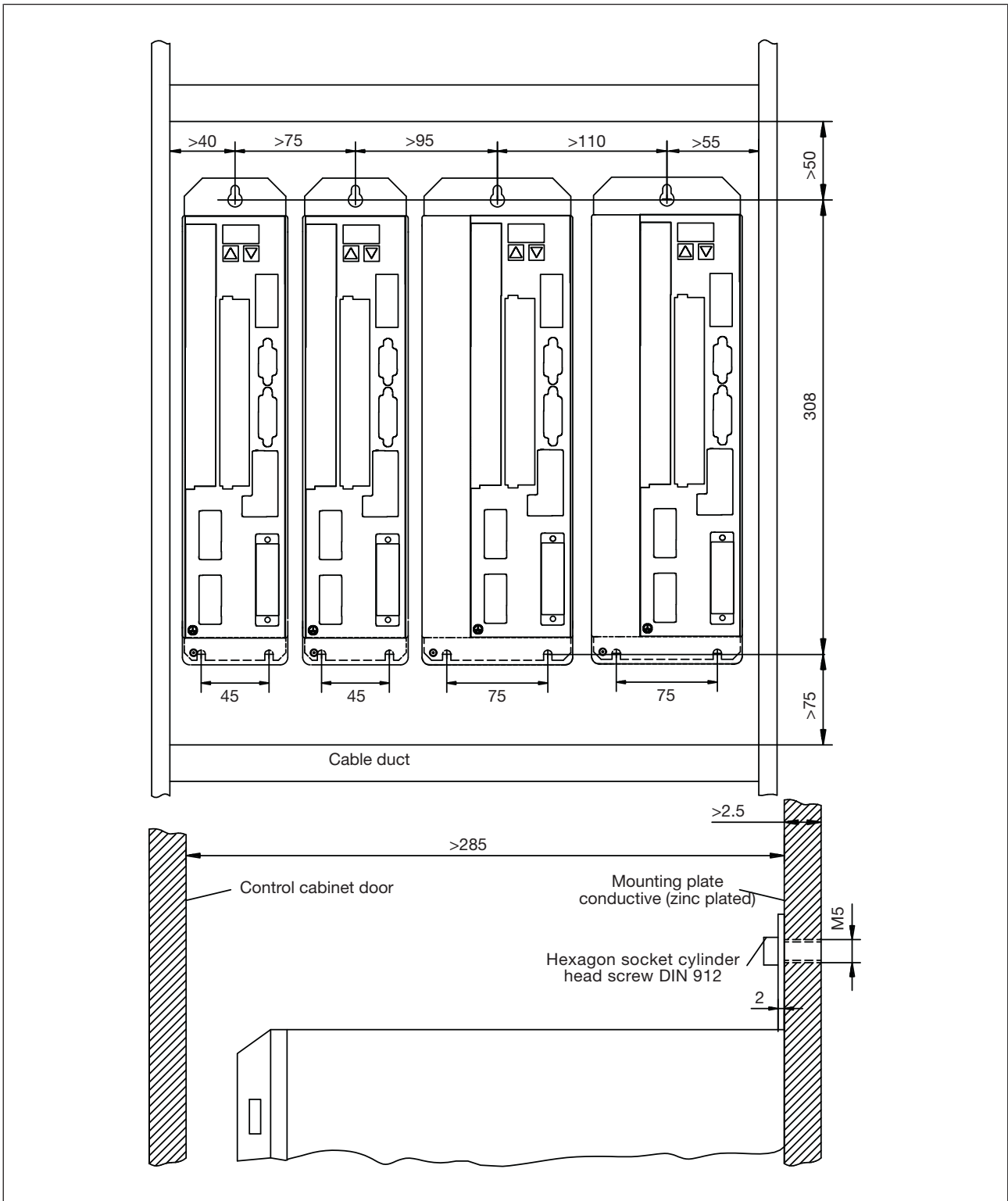
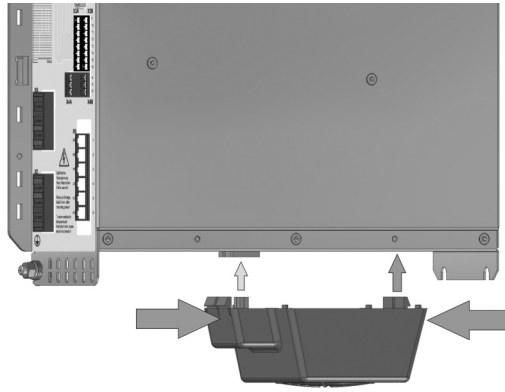

Fig.: Installing the servo amplifier in a control cabinet

5.4 Installing and removing the fan

The fan does not require wiring. Connectors built into the fan housing plug into sockets underneath the servo amplifier.

Installation and removal: Fan on servo amplifiers with 70 mm width



Removal

Gently compress the fan housing lengthwise.

Pull the fan housing downwards.

Assembly

Position the fan so that the green connector is aligned with the socket on the PMCprotego D.

Push the fan on to the connector until the fan housing clicks into place. Gently compress the fan housing lengthwise.

Installation and removal: Fan on servo amplifiers with 100 mm width

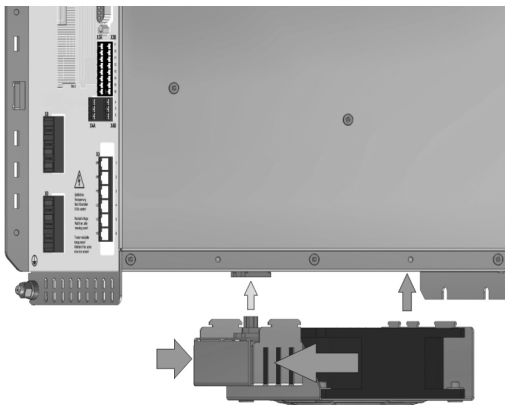

Removal

Gently compress the fan housing crosswise.

Pull the fan housing downwards.

Assembly

Position the fan so that the green connector is aligned with the socket on the PMCprotego D.

Push the fan on to the connector until the fan housing clicks into place. You can help by gently compressing the fan housing crosswise.

5.5 Installing the expansion cards



INFORMATION

Please note: Do not twist the expansion card as you insert it or damage any components.

5.5.1 Expansion cards for slot 1

The following expansion cards are available for slot 1:

- ▶ I/O expansion
- ▶ PROFIBUS DP
- ▶ PROFINET

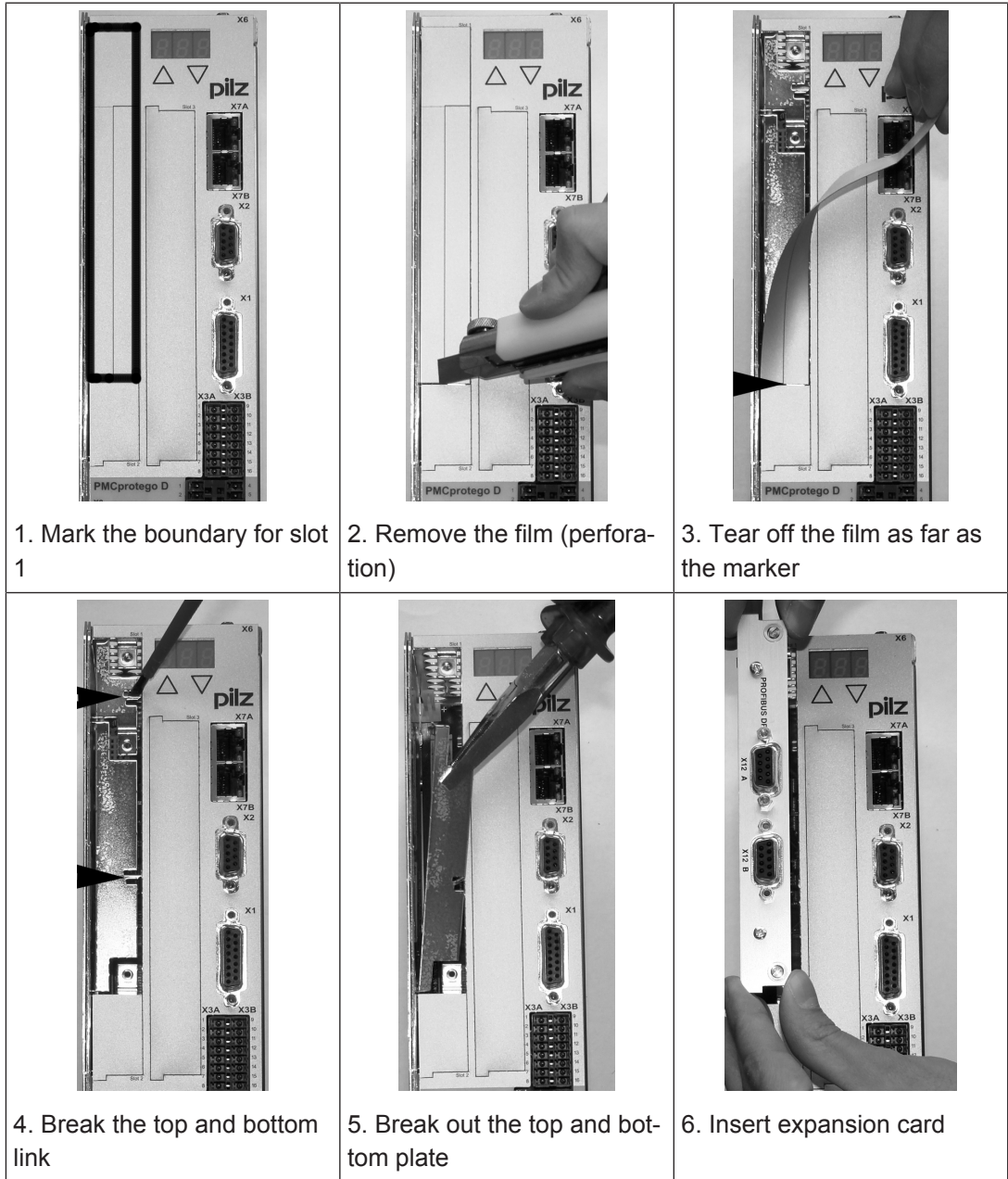

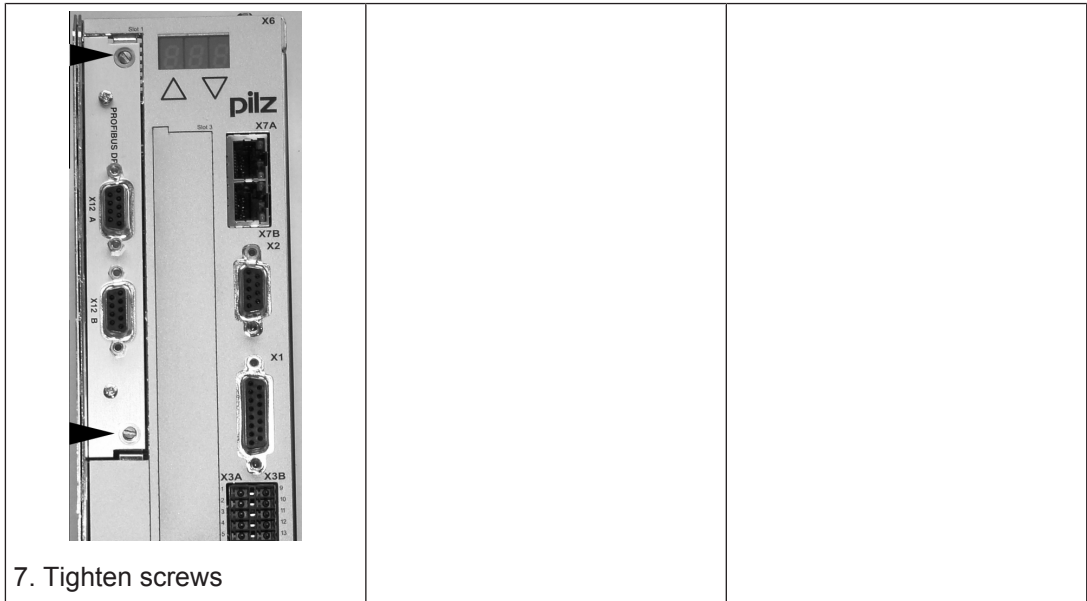

5.5.2 Expansion cards for slot 2

The following expansion cards are available for slot 2:

- ▶ PMC expansion card PosI/O
- ▶ PMC expansion card PosI/O-AIO
- ▶ Fan controller (available only on request, cannot be retrofitted)

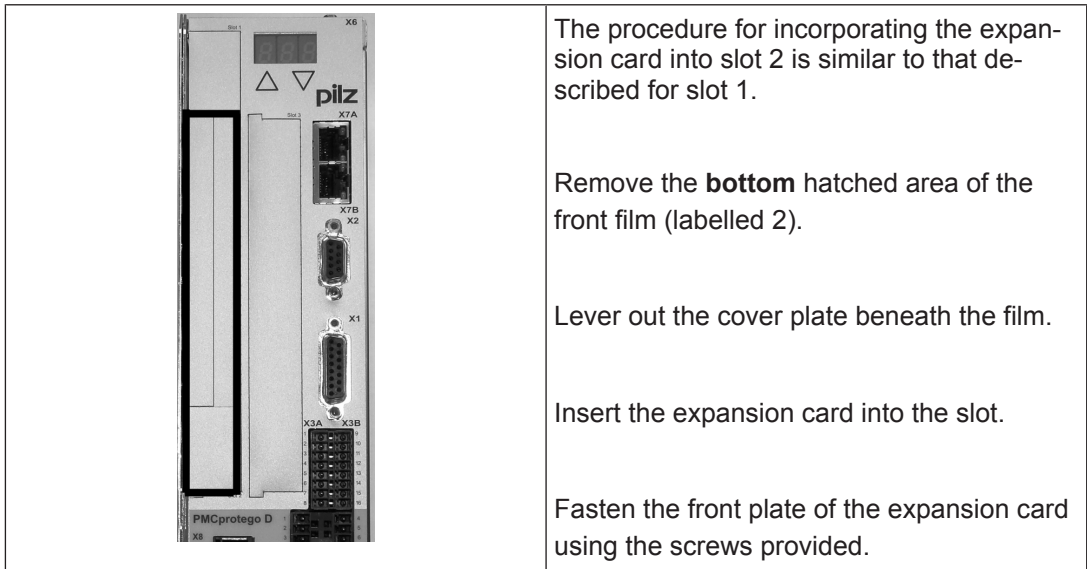

5.5.3 Expansion cards for slot 3

The following expansion cards are available for slot 3:

- ▶ PMCprotego S1-2, PMCprotego S2-2
- ▶ PMC expansion card PosI/O
- ▶ PMC expansion card PosI/O-AIO
- ▶ Fan controller (available only on request, cannot be retrofitted)

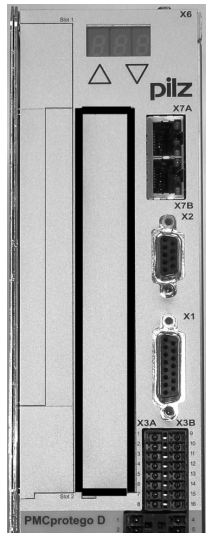

The procedure for incorporating the expansion card into slot 3 is similar to that described for slot 1.

Remove the yellow marked area of the front film (labelled 3).

Lever out the cover plate beneath the film.

Using suitable pliers, pull out the blank in the slot (STO bridge).

Please note: You should retain the blank. It must be inserted if no expansion card is plugged into slot 3. If not, it will not be possible to enable the servo amplifier.

Insert the expansion card into the slot.

Fasten the front plate of the expansion card using the screws provided.

6 Wiring

6.1 Connector description

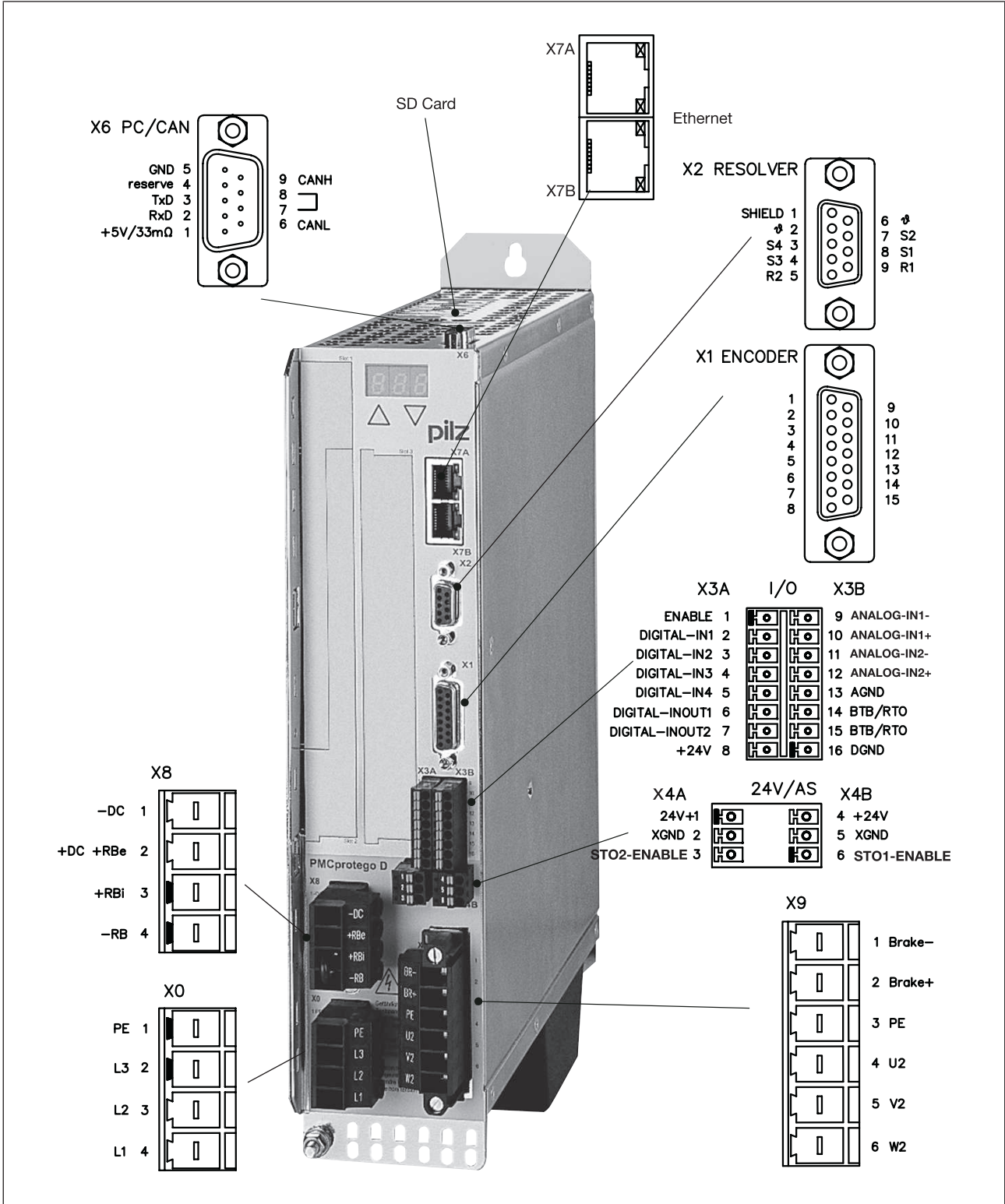





Fig.: Connector description for PMCprotego D

6.2 Block diagram

The following block diagram provides an overview of the wiring for the PMCprotego D. The wiring of the expansion cards is not shown.

The block diagram also shows the position and type of shield connections, the PE and the connections of the attached device to the mounting plate.

*) Please note: If you are using an external brake resistor, remove the link between Pin 3 and 4 on X3.

Display	Connection	Description
	X1, X2, X6, X9	Shield in the connector housing
	X3, X8	Shield on the front plate
	PE	Protective earth, PE
	Mounting plate	Wide area, electrical connection between the designated device and the mounting plate in the control cabinet

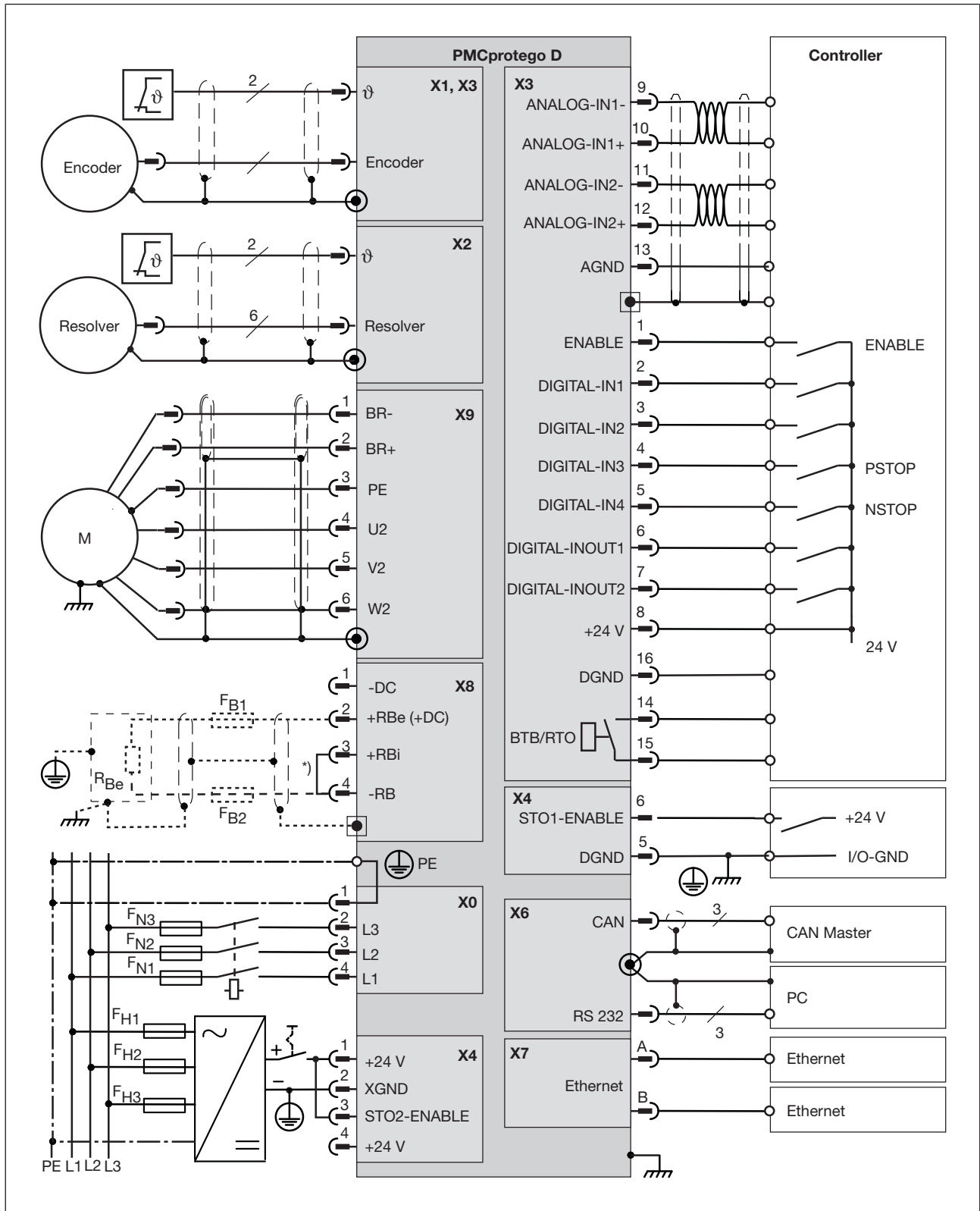

Fig.: Block diagram of PMCprotego

6.3 Notes on wiring

Performance data

- ▶ Check the allocation of servo amplifier and motor. Compare the units' mains voltage and rated current.
- ▶ Make sure that the maximum permitted rated voltage at connections L1, L2, L3 or +DC, -DC is not exceeded by more than 10 % (see EN 60204-1, paragraph 4.3.1). Otherwise the servo amplifier (e.g. brake chopper) could be damaged.

Fuse protection

- ▶ Provide adequate fuse protection for the mains voltage and 24 V supply. Please also refer to the guidelines provided under "Residual current devices".

Cable layout

- ▶ Power and control cables should be laid separately. We recommend a distance greater than 20 cm. This will improve EMC noise immunity.
- ▶ If you are using motor power cables with integrated brake control wires, the brake control wires must be shielded separately. Connect the shield at both ends.

Shielding

- ▶ Shields should be connected over a wide area (low impedance). Use metallised connector housing or shielded terminals. Information on the connection technology can be found under "Connection cables".
- ▶ On shielded cables, the shielding must be continuous. Any interruptions must be bridged over a wide area.
- ▶ Cables between the servo amplifier and the external brake resistor should have their own shield.

Connection cables

- ▶ All power cables should have an adequate cross section in accordance with EN 60204 (see section entitled "Connection cables"). To achieve the maximum cable length, use cable material of the quality described under "Connection cables".

E-STOP circuit

- ▶ The relay output for operational readiness (BTB) must be incorporated into the plant's emergency stop circuit. BTB contact: No safe signal

Please note the following safety guidelines:



DANGER!

Risk of electrocution!

Never unplug the electrical connections on the servo amplifier while voltage is applied.

Switch off the supply voltages!

Residual charges in the capacitors may still show hazardous values after the mains voltage is switched off:

- 5 min on units with 1.5 A to 12 A continuous current
- 8 min on units with 24 A continuous current

Measure the voltage on the intermediate circuit (+DC/-DC). Wait until the voltage has dropped below 40 VDC.

Wait at least eight minutes before touching any parts that carry voltage (e.g. contacts) or loosening the connections.



DANGER!

Risk of electrocution!

Never wire the electrical connections on the servo amplifier while voltage is applied.

Switch off the mains voltages and 24 V supply!

Make sure that the control cabinet is made safe, e.g. through an access lock or warning signs. Do not switch on the voltages until the system is commissioned!

6.3.1 Contact protection

6.3.1.1 Leakage current

The leakage current via the protective earth conductor PE is the sum of the leakage currents from the devices and cables.

The frequency of the leakage current is made up of a number of frequencies. The residual current devices evaluate the 50 Hz current. It's not possible to measure the leakage currents using a conventional multimeter because these too are standardised at 50 Hz current.

The ready-made cables from Pilz are low capacity. The leakage current can be calculated approximately as follows (at 400 V mains voltage):

- ▶ $I_{abl} = n \times 20 \text{ mA} + L \times 1 \text{ mA/m}$ at 8 kHz clock frequency at the output stage
- ▶ $I_{abl} = n \times 20 \text{ mA} + L \times 2 \text{ mA/m}$ at 16 kHz clock frequency at the output stage

I_{abl} = leakage current, n = number of servo amplifiers, L = length of motor cable

With other mains voltages, the leakage current will vary in proportion to the voltage.

Example: 2 x servo amplifiers + 25 m motor cable at 8 kHz clock frequency:

$2 \times 20 \text{ mA} + 25 \text{ m} \times 1 \text{ mA/m} = 65 \text{ mA}$ leakage current.



INFORMATION

The leakage current to PE is more than 3.5 mA. In accordance with EN 61800-5-1, the PE connection must either be duplicated or a connection cable with a cross section $> 10 \text{ mm}^2$ must be used. Use the PE terminal and PE bolt.

The following measures can be taken to minimise leakage currents:

- ▶ Reduce the length of the motor cable
- ▶ Use lower capacity cables (see section entitled "Connection cables")
- ▶ Remove external EMC filters (interference suppression measures are integrated within the servo amplifier)

6.3.1.2

Residual current devices FI

In accordance with DIN IEC 60364-4-41 - Electrical installations of buildings - and EN 60204 - Electrical equipment of machines - it is possible to use residual current devices (hereafter called FI), if the necessary provisions are met.

The servo amplifiers constitute a 3-phase system with a B6 bridge. Universal current sensitive FIs must be used to enable any potential DC fault current to be detected.

For a general rule of thumb for determining leakage current, please see the section entitled "Leakage current".

Fault current measurement on the FI

Fault current	Protection
10 - 30 mA	Protection against "indirect contact" (personal fire protection) for stationary and mobile electrical work equipment, as well as "direct contact".
50 - 300 mA	Protection against "indirect contact" (personal fire protection) for stationary electrical work equipment



INFORMATION

Recommendation: For protection against direct contact (with motor cable runs $< 5 \text{ m}$), we recommend that each servo amplifier is protected individually using a 30 mA universal current sensitive residual current device.

Selective FI residual current devices will stop the protective device being triggered inadvertently.

6.3.1.3 Isolating transformer

The servo amplifier can also be operated via an isolating transformer when:

- ▶ Protection against indirect contact is absolutely essential, despite a higher leakage current
- ▶ An alternative method of contact protection is sought.

For details of how to connect the isolating transformer, please see the section under “Wiring”.



INFORMATION

We recommend that the cables between the transformer and the servo amplifier be kept as short as possible.

6.3.2 Connection cables

Single-axis systems

We recommend the following cable cross sections in accordance with EN 60204:

Connection	Connection designation	Device	Cable cross section	Conditions
Mains voltage AC	X0	1.5 A, 3 A, 6 A 12 A 24 A	1.5 mm ² 2.5 mm ² 4 mm ²	600 V
DC intermediate circuit Brake resistor	X8	1.5 A, 3 A, 6 A 12 A, 24 A	6 mm ²	1000 V, shielded for lengths > 20 cm
Motor cables without choke, max. 25 m	X9	1.5 A, 3 A, 6 A 12 A 24 A	4 (6) mm ²	600 V, shielded, C < 150 pF/m
Motor cables with choke, 25 – 50 m*	X9	1.5 A, 3 A, 6 A 12 A 24 A	4 (6) mm ²	600 V, shielded, C < 150 pF/m
Resolver, thermal switch, max. 100 m*	X2	All	0.25 mm ²	Twisted pair, shielded, C < 120pF/m
Encoder, thermal switch, Max. 50 m*	X1, X3	All	0.25 mm ²	Twisted pair, shielded
Incremental encoder, thermal switch, Max. 25 m	X1	All	0.25 mm ²	Twisted pair, shielded

Connection	Connection designation	Device	Cable cross section	Conditions
Analogue inputs, AGND, max 30 m	X3	All	Max. 1.5 mm ²	Twisted pair, shielded
Digital inputs and outputs, BTB, DGND, max. 30 m	X3	All	Max. 1.5 mm ²	
Holding brake (motor)	X9	All	Max. 1.5 mm ²	600 V, shielded, check voltage drop
+24 V/XGND, max. 30 m	X3, X4	All	Max. 1.5 mm ²	Check voltage drop

* North America: max. 39 m length, Europe: up to max. length

6.4 Wiring procedure

The following guidelines are intended to help you carry out the electrical installation in a sensible order, without forgetting anything important.

Choice of cable

- ▶ Select cables in accordance with EN 60204

Earthing, shielding

- ▶ Make sure that shielding and earthing are EMC-compliant
- ▶ Earth the mounting plate, the motor housing and the control system's ground terminal. Information on the connection technology can be found under "Block diagram".

Wiring

- ▶ Lay the power and control cables separately
- ▶ Incorporate the relay output for operational readiness (BTB) into the plant's safety circuit
- ▶ Connect the servo amplifier's digital inputs and outputs
- ▶ Connect the AGND earth (even if a fieldbus is used)
- ▶ If necessary, connect the analogue setpoint value
- ▶ Connect the encoder (feedback)
- ▶ Connect the expansion card
- ▶ Connect the motor cables
- ▶ Connect the shielding on both ends; use a motor choke if the cable runs are over 25 m
- ▶ Connect the motor holding brake, connect the shielding on both ends
- ▶ If necessary, connect the external brake resistor (with fuse protection)
- ▶ Connect the 24 VDC supply voltage (for maximum permitted voltage values see chapter entitled "Technical Details")
- ▶ Connect the mains voltage (for maximum permitted voltage values see chapter entitled "Technical Details"); for information on FI residual current devices see section entitled "Residual current devices")
- ▶ Connect the PC (see section entitled "Communications interfaces")

Check

- ▶ Check the wiring against the wiring diagrams

6.5 EMC-compliant wiring

In terms of electromagnetic compatibility (EMC), the servo amplifier meets the requirements of the following standards and laws:

- ▶ The EMC Directive 2014/30/EU
- ▶ The Low Voltage Directive 2014/35/EU.
- ▶ The EMC product standard EN 61800-3, which contains limit values and test methods for noise emission and immunity for adjustable speed electrical power drive systems (PDS):
 - Noise immunity: "Second environment" category (industrial environment)
 - Noise emission:
 - Category C2 (length of motor cable \leq 10 m)
 - Category C3 (length of motor cable \geq 10 m)

Measures for ensuring the wiring is EMC-compliant are:

- ▶ Earthing
- ▶ Shielding
- ▶ Filter
- ▶ Chokes

**WARNING!**

In a residential environment this product may cause high-frequency noise, so that suppression measures may be required.

6.5.1 Earthing

Earthing measures are a prerequisite for the effective use of additional EMC measures such as shielding or filters:

- ▶ All earthing points should be fed directly to the central earth bar (equipotential bonding bar).
- ▶ The connections must be low impedance and must be good conductors.
- ▶ Connections should be kept as short as possible.
- ▶ Connections to the earth bar should always be in star form.
- ▶ Connections should be protected from corrosion.
- ▶ Flexible earthing straps should be used on moving earth parts (e.g. machine parts, gates). Ensure these earthing straps are as short and wide as possible.
- ▶ Unused wires in a cable should be earthed at both ends.

6.5.2 Shielding

Shielding measures reduce noise energy (immunity of adjacent systems and devices to external influences):

- ▶ Correct shielding of the following cables avoids interference coupling with
 - Motor cables
 - Cables to the external brake resistor
 - Encoder cables
 - Cables with digital and analogue signals
 - Cables to communications interfaces
- ▶ All shielded cables are to be attached at both ends to the shield terminals provided or should be connected to the connector housing.
- ▶ Use cables with braided shield, with a minimum cover area of 80 %.
- ▶ Any interruptions to the shielding e.g. at terminals, contactors, chokes, should be bridged at low impedance over a wide area.
- ▶ All connectors or sockets should be fastened with screws to ensure ample, conductive contact between the braided shield and the front plate.

6.5.2.1 Shield connection on the front plate

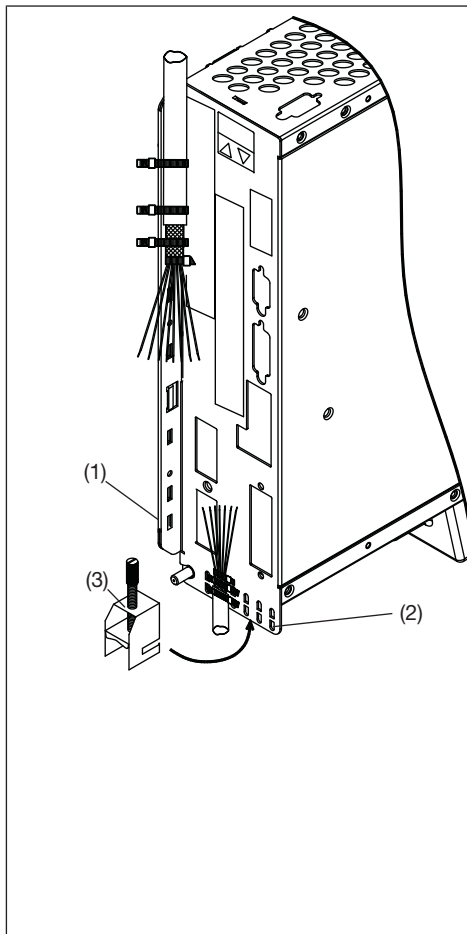

Remove the outer cable sheath and the braided shield to the required wire length. Secure the wires with a cable tie.

Remove the outer cable sheath to a length of approx. 30 mm. Be careful not to damage the braided shield.

Strip all the wires and fit end ferrules.

Use the cable ties to attach the cable to the shielding plate on the side (1) or bottom (2) of the servo amplifier. Press the cable's braided shield firmly against the shielding plate on the servo amplifier using a cable tie.

Alternatively you can use the shielded connection terminals (3) (available as an accessory). These hook into the bottom shielding plate and guarantee optimum contact between the shield and the shielding plate.

6.5.2.2 Motor connection

The cable shield for the motor cable is connected to the servo amplifier housing via the shielding plate.

Use the ready-made motor cable from Pilz (accessory). However, If you wish to wire your own motor connector, follow the instructions below:

	<p>Strip the outer cable sheath to approx. 20-25 mm in length, without damaging the braided shield.</p> <p>Push the braided shield back over the cable.</p> <p>Shorten all the wires except for the protective earth PE (green/yellow) by approx. 20 mm. The PE wire is now the longest.</p> <p>Strip all the wires and fit end ferrules.</p> <p>Wire the connector as shown in the connection diagram.</p> <p>Hook the shielded connection terminal on to the shielding plate. Screw the shielded connection terminal into place. This provides ample, conductive contact between the braided shield and the front plate.</p> <p>Plug the connector into the slot on the front of the servo amplifier.</p>
--	--

6.5.3 Filters

Noise suppression filters are integrated within the servo amplifier for the mains voltage and 24 V supply voltage.

These noise suppression filters are used to:

- ▶ Protect the devices from conducted, high frequency disturbances (noise immunity)
- ▶ Reduce a device's high frequency disturbances. These disturbances are emitted via the the mains cable or via emissions from the mains cable. The noise suppression filters limit the noise emissions to a specified amount.

Filters have leakage currents which may be considerably greater than the rated values in the event of a fault (phase failure, unbalanced load) (see section entitled "Leakage current").

Please note the following if additional filter measures are required:

- ▶ Earth the filter to avoid hazardous voltages
- ▶ Leakage currents are high frequency disturbances, so earth the filter at low impedance over a wide area.

**WARNING!**

In a residential environment this product may cause high-frequency noise, so that suppression measures may be required.

6.5.4 Chokes

If motor cables are > 25 m, a choke must be used on the servo amplifier's output.

The choke is used to

- ▶ Reduce the level of interference on the motor cable
- ▶ Deal with EMC problems retrospectively
- ▶ Protect the semiconductor on the inverted rectifier in the case of an earth fault or short circuit
- ▶ Protect the motor from high voltage rise rates

Additional earthing measures are unnecessary because, unlike filters, chokes do not have to divert disturbances to earth.

6.6 Power element

6.6.1 Mains voltage

**CAUTION!****Risk of overvoltage**

Overvoltage can destroy the device and lead to minor injuries.

Select the correct mains voltage and the correct device type.

Please note the following important points under "Mains voltage", in the chapter entitled "Function description":

- ▶ The mains voltage requirements (network configurations)
- ▶ The use of isolating transformers

Connector X0	Pin	Designation	Description
X0 1 PE 2 L3 3 L2 4 L1 	1	PE	Earth conductor
	2	L3	Mains voltage phase L3
	3	L2	Mains voltage phase L2
	4	L1	Mains voltage phase L1

Connector pin assignment

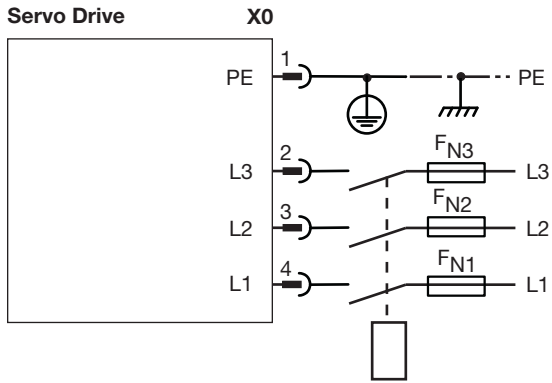
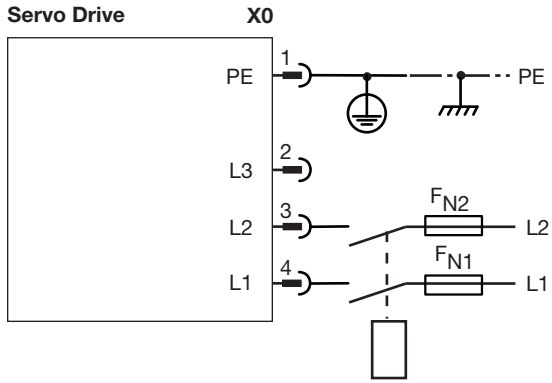
<p>Mains voltage for power element</p> 	<p>Three-phase</p> <p>208 - 480 VAC, star 110 – 230 VAC delta, star</p> <p>See Mains voltage [31]</p>
<p>Mains voltage for power element</p> 	<p>Two-phase without neutral conductor</p> <p>110 – 230 VAC Delta, star</p> <p>See Mains voltage [31]</p>
<p>Mains voltage for power element</p>	<p>Single phase with neutral conductor</p>

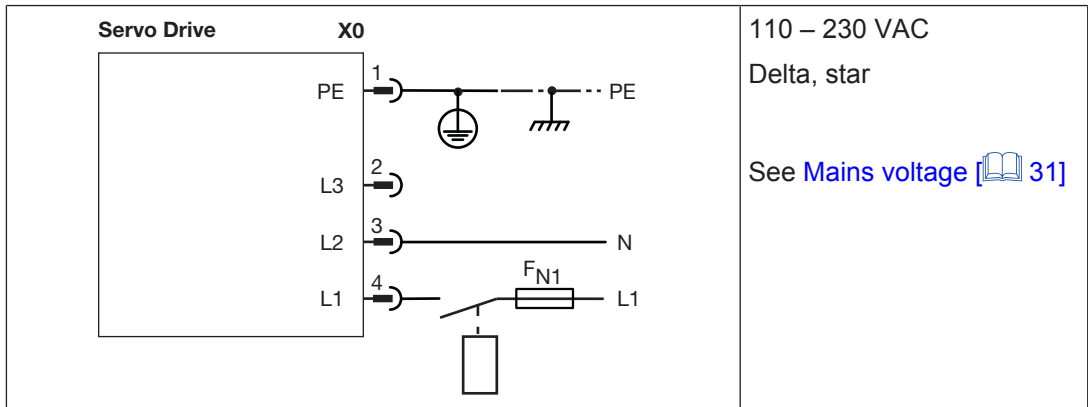

110 – 230 VAC

Delta, star

See [Mains voltage \[31\]](#)

Connection

Use the following fuses for F_{N1} , F_{N2} and F_{N3} , depending on the device type:

Device type	01, 03	06	12	24
Blow-out fuse or similar	6 AT (6 A)	10 AT (10 A)*	16 AT (15 A)*	30/35 AT (30 A)*

Protection

European types: gRL or gL 400V/500V, T = slow acting,

American types: Fuse classes RK5, CC, J or T, 600VAC 200 kA, time-delay

6.6.2 Motor with brake



DANGER!

Risk from non-safety-related activation of the motor holding brake!

Activation of a holding brake via output BR+/BR- of the servo amplifier is not safety-related. Depending on the application, hazardous motor movements may cause serious injury or death.

A motor holding brake activated by the servo amplifier alone is **not suitable for personal protection**.

Block the drive through an additional mechanical holding brake, which is activated safely (e.g. with the safety card PMCprotego S1-2).

- ▶ The motor and motor holding brake are connected to the same terminal on the servo amplifier. The wires can be carried within the same cable. Note: The wires for the motor holding brake must have separate shielding.
- ▶ The motor connection must be shielded appropriately.

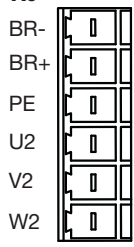
Connector X9	Pin	Designation	Description
	1	BR-	Brake-
	2	BR+	Brake+
	3	PE	Earth conductor
	4	U2	Motor connection phase U
	5	V2	Motor connection phase V
	6	W2	Motor connection phase W

Connector pin assignment

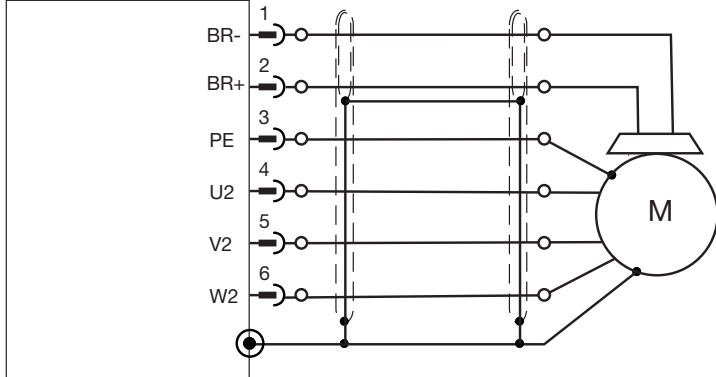
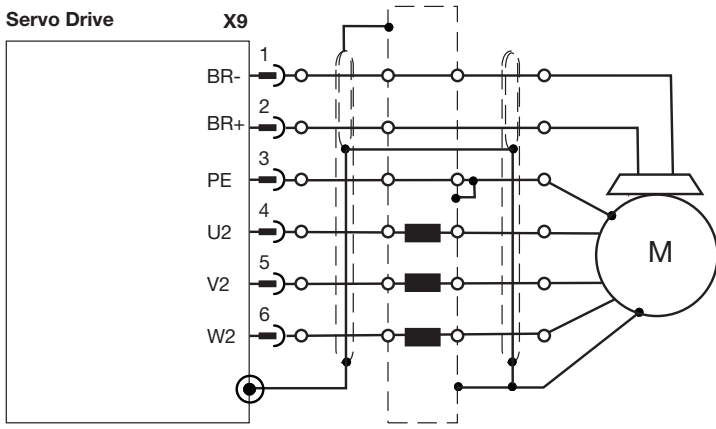
Output circuit	Motor with brake
<p>Servo Drive X9</p> 	<p>Cable length ≤ 25m</p> <p>Wires to the brake (BR+/BR-) should be shielded separately</p> <p>Connect the shielding on both ends</p>
<p>Servo Drive X9</p> 	<p>Cable runs > 25m to max. 50 m</p> <p>Leakage currents on long cable runs place a load on the servo amplifier's output stage.</p> <p>Wire the motor choke (accessories) into the motor cable, close to the amplifier.</p> <p>The wires to the brake (BR+/BR-) should be shielded separately.</p> <p>Connect the shielding on both ends.</p>

Connection

6.6.3 External brake resistor

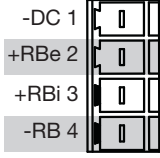
Connector X8	Pin	Designation	Description
	2	+RBe	Connection of external brake resistor +
	4	-RB	Connection of external brake resistor -

Connector pin assignment

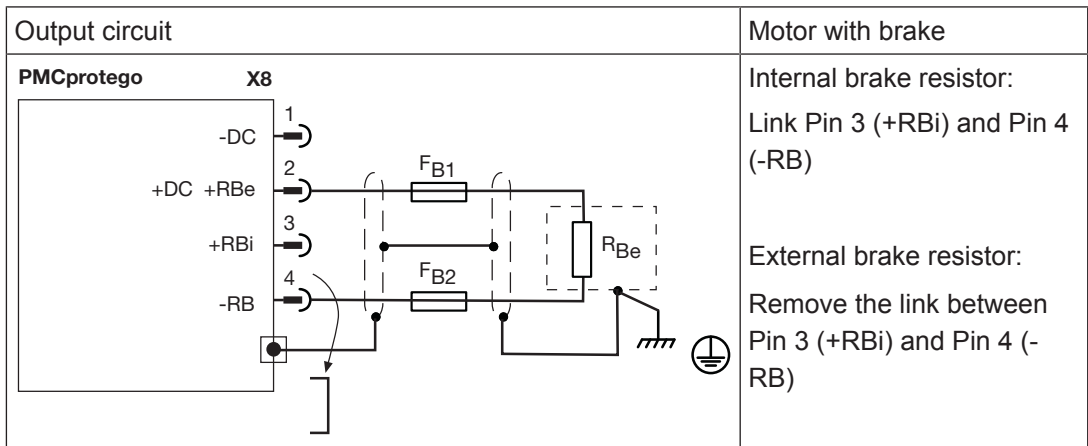

Connection

Use the following fuses for F_{B1} and F_{B2} , depending on the device type.



INFORMATION

The specified fuses do not protect the external brake resistor from thermal overload. Monitoring is carried out by the servo amplifier via software. It is assumed that the parameters on the servo amplifier are set correctly. The fuses should provide protection from consequential damage in the event of a short circuit and earth fault.

Fuses – Use in CE regions

Rated voltage Mains voltage	Voltage class of DC fuse	Device type 01, 03	Device type 06	Device type 12	Device type 24
110/115 V	min. 250 VDC	10 A	10 A	10 A	15 A
230 V	min. 250 VDC	20 A	20 A	20 A	30/32 A
400 V	min. 440 VDC	40 A	40 A	40 A	50 A
480 V	600 – 1000 VDC	40 A	40 A	40 A	50 A
Cable cross section	---	6 mm ²	6 mm ²	6 mm ²	6 mm ²

Fuse type

- ▶ With VBUSBAL (rated voltage power supply 110 V – 400 V):
e.g. fuse type class gRL (gS) from Siba, size 22x58 AC 690/700 V and DC 440 V, 30 kA
- ▶ With VBUSBAL (rated voltage power supply 400V – 480 V):
e.g. fuse type class aR from Siba, size 14x51 mm DC 700 V, 30/50 kA

Fuse holder

2-pin fuse holder: (finger-safe design):

- ▶ 14x51 mm: Siba, Part No: 51 058 04.2
- ▶ 22x58 mm: Siba, Part No: 51 060 04.2

Fuses – Use in UL-cUL regions

Rated voltage Mains voltage	Voltage class of DC fuse	Device type 01, 03	Device type 06	Device type 12	Device type 24
110/115 V	min. 250 VDC	10 A	10 A	10 A	15 A
230 V	min. 250 VDC	20 A	20 A	20 A	30/32 A
400 V	min. 440 VDC	40 A	40 A	40 A	50 A
480 V	600 – 1000 VDC	40 A	40 A	40 A	50 A
Cable cross section	---	6 mm ²	6 mm ²	6 mm ²	6 mm ²

Fuse type

- ▶ Bussmann: up to 50 A: FWP-xxA14F, size 14x51 mm with 800 Vdc UL approval
- ▶ Bussmann: up to 100 A: FWP-zzzA22F, size 22.2x58 mm with 500 Vdc UL approval

Fuse holder

- ▶ Bussmann: CH142D, CH222B

6.6.4 Intermediate circuit

The connections for the intermediate circuit are

- ▶ Not short circuit and earth fault proof.
- ▶ **Not** reverse polarity protected.

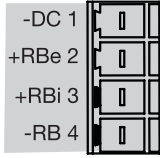
Connector X8	Pin	Designation	Description
	1	-DC	Intermediate circuit voltage -DC
	2	+Rbe/+DC	Intermediate circuit voltage +DC Connection of external brake resistor +
	3	+RBi	Internal brake resistor
	4	-RB	Connection of external brake resistor -

Connector pin assignment

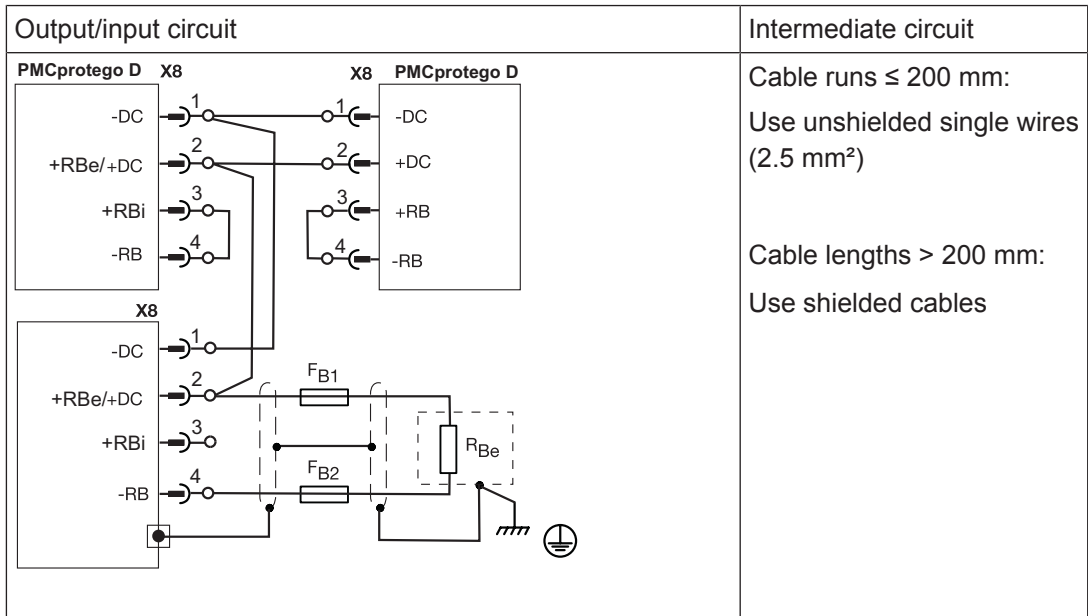

Connection

Multi-axis systems

With multi-axis systems please note the specific conditions of your plant. On multi-axis systems, servo amplifiers can be interconnected via the intermediate circuit.

As with single-axis systems, max. cable runs can only be achieved if the material requirements are strictly observed.



NOTICE

High transient currents between connected intermediate circuits can destroy the servo amplifier. v

- Supply the servo amplifier from the same mains (identical mains voltage).
- Do not wire servo amplifiers with smaller outputs between two servo amplifiers with higher outputs.
- Ensure that the total rated currents of all the servo amplifiers connected in parallel in an intermediate circuit does not exceed 48 A.

6.6.5 Energy store PMCenergy SD

PMCenergy SD	
	Energy store Dimensions (HxWxD): 300 x 100 x 201 mm

The energy stores are connected to the direct current intermediate circuit and they store the energy that the motor produces in the generating operation. This energy is usually implemented via brake resistors in power dissipation.

If the energy is required, for example, with the next acceleration cycle, the energy stores supply the saved energy back in the intermediate circuit.

Energy store	Description
PMCenergy SD. B	Dynamic energy store The energy stored in the energy store during generating braking will be available for the next acceleration. The module's inception voltage is calculated automatically during the first load cycles.
PMCenergy SD. E	Expansion module The expansion module is connected to the PMCenergy SD.B energy store and it increases its energy store.

Type code

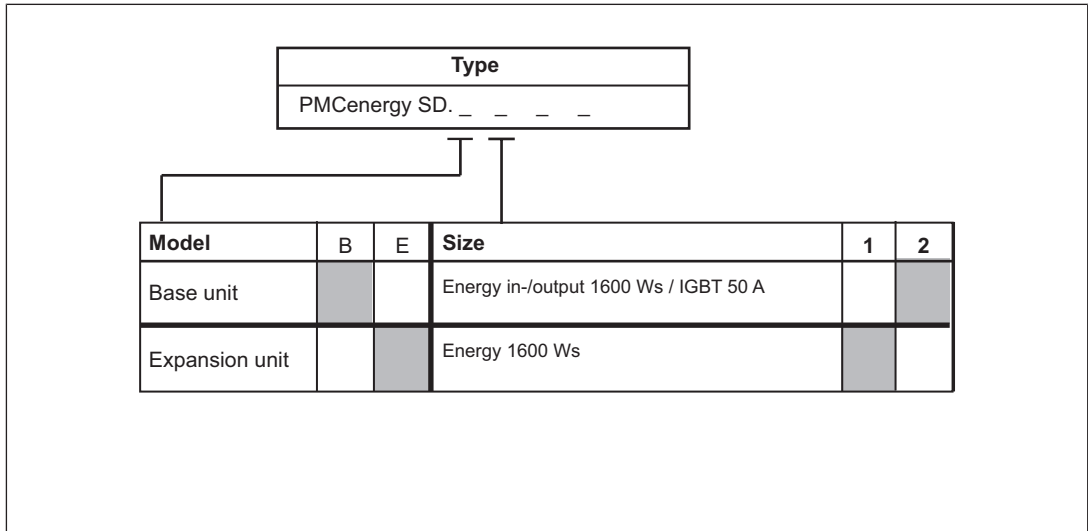

Fig.: PMCEnergy SD, type key

Legend

- Base unit Energy store
- Expansion unit Expansion module



INFORMATION

For notes on assembly, installation and commissioning please refer to the operating manual of the energy storage module.

Connection examples



CAUTION!

Risk of material damage

When transposing the DC+/DC connections, the energy stores may be destroyed. Long cable lengths can lead to errors.

Ensure that the polarity is correct.

Do not exceed the maximum cable length of 500 mm between the servo amplifier and the energy store. Twist the cables DC+/DC-. Longer cable lengths require shielding.



DANGER!

**Hazard due to electric shock or arcing,
DC voltage up to 900 V**

When voltage is applied, contact with live components could result in serious or even fatal injury from an electric shock. The self-discharge time of the modules may be more than one hour.

Switch off the mains voltage (enabling). Work only on the connections when the plant is without voltage.

Check the state of charge with a measuring device that is suitable for DC voltage up to 1000 V.

When measuring a voltage of over 50 V between the terminals DC+/DC- or to earth, discharge the modules manually (see Energy store operating manual).

Type	Description
	For notes on commissioning, please refer to the operating manual of the energy store.
PMCenergy SD.B	Connect the BR connection to the servo amplifier with the most frequent regenerative brake processes in the system. For commissioning, enable the servo amplifier and start a driving profile that leads to the reaction of the brake chopper. The energy store determines the chopper threshold and starts loading, the LED flashes. The absorbed energy is used in the next acceleration process.

Connector X8	Pin	Designation	Description	
	1	-DC	Energy store -DC	
	2	+RBe/+DC	Energy store +DC	
	3	+RBi	bridged	Energy store BR
	4	-RB		

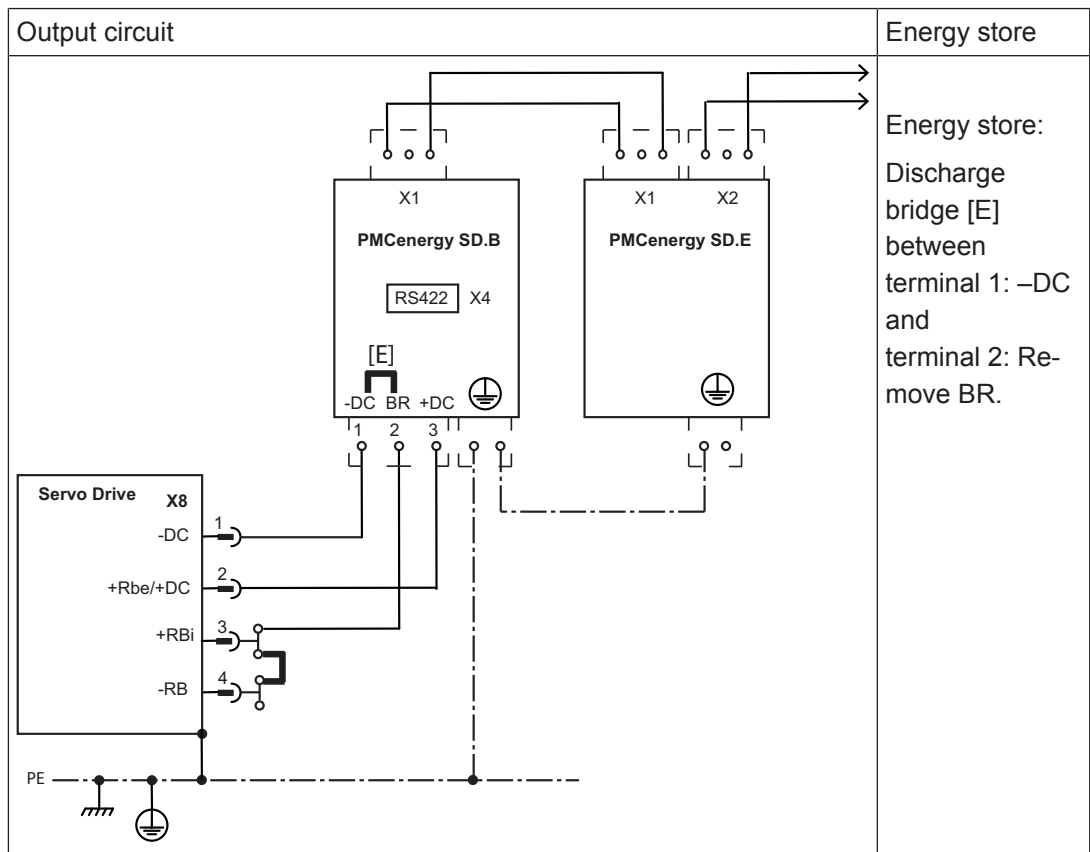

Connection

6.7 Control element

6.7.1 Supply voltage 24 VDC



WARNING!
Electric shock!

Safe electrical isolation must be ensured for the external power supply that generates the supply voltage. Failure to do so could result in electric shock. The power supplies must comply with EN 60950-1, 05/2006, EN 61558-2-6, 11/1997.

Connector X4A/X4B	Pin	Designation	Description
	1	+24 V	Supply voltage + 24 VDC
	2	XGND	Earth for supply voltage
	4	+24 V	Supply voltage + 24 VDC

Connector pin assignment

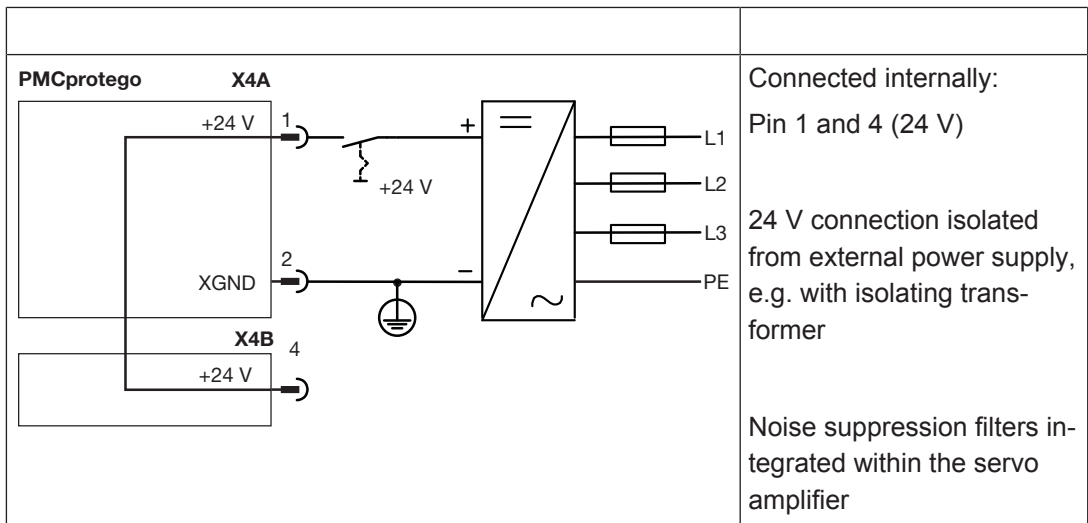

Connection

Use the following fuses:

Device type	PMCprotego D1 ... D24	Type
Blow-out fuse or similar	8 A	Fine wire fuse* or Circuit breaker**
*Fine wire fuse 6.3 x 32 mm, fuse holder in terminal blocks (35 mm mounting rail installation) integrated, as for example from Phoenix Contact 4ST-HESI (6.3 x 32 mm)		
**Circuit breakers, for example from ABB for 60 VDC in accordance with UL 489 for Branch Circuit Protection: Type range: S201 DC-k and S201 DC-Z with and without integral auxiliary contact.		

6.7.2 Digital inputs

Connector X3A/X3B	Pin	Designation	Description
	1	ENABLE	Enable input
	2	DIGITAL-IN1	Digital input 1
	3	DIGITAL-IN2	Digital input 2
	4	DIGITAL-IN3	Digital input 3
	5	DIGITAL-IN4	Digital input 4
	6	DIGITAL-INOUT 1	Digital input or output 1
	7	DIGITAL-INOUT 2	Digital input or output 2
	16	DGND	Reference earth for digital inputs and outputs

Connector pin assignment

Connector X4A/X4B	Pin	Designation	Description
	3	STO2-ENABLE	STO – Safe torque off, 2nd shut-down route
	2, 5	XGND	Reference earth for 24 VDC
	6	STO1-ENABLE	STO – Safe torque off, 1st shut-down route

Input circuit	Digital input
	<p>24 VDC</p> <p>Referenced to earth: Always connect DGND (X3B/16) to I/O-GND on the control system</p> <p>PSTOP, NSTOP: Evaluation of limit switch</p> <p>Pins 6 and 7 are configured as digital inputs in the commissioning software</p>

Connection

PMCprotego D **without** a safety card

Input circuit	Digital input: STO1-ENABLE/STO2-ENABLE
	<p>Single-channel</p> <p>24 VDC</p> <p>Referenced to earth: Always connect XGND (X4B/5) to I/O-GND on the control system</p> <p>Connect a safe semiconductor output or positive-guided relay contact</p>

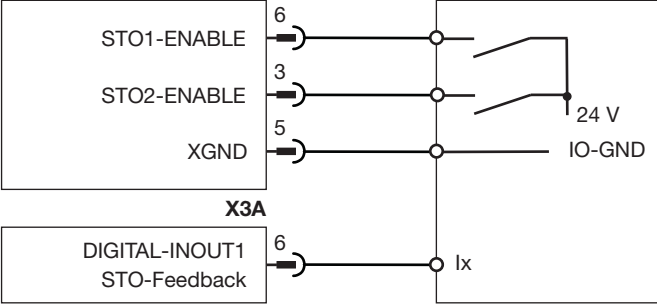
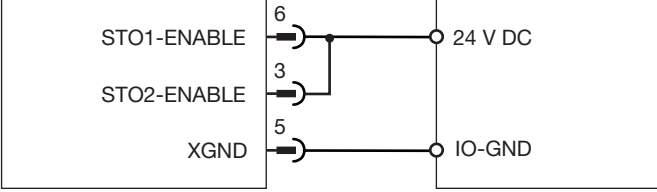
<p>PMCprotego D X4A/B</p> 	<p>Dual-channel</p> <p>24 VDC</p> <p>Referenced to earth: Always connect XGND (X4B/5) to I/O-GND on the control system</p> <p>Connect the feedback signal for the state of the pulse disabler to a digital output (e.g. X3A/6)</p>
<p>PMCprotego D X4A/B</p> 	<p>If a safety function STO is not required:</p> <p>Connect 24 VDC</p> <p>Referenced to earth: Always connect XGND (X4B/5) to I/O-GND on the control system</p>

PMCprotego D **with** a safety card

<p>Input circuit</p>	<p>Digital input: STO1-ENABLE/STO2-ENABLE</p>
	<p>Application: PMCprotego S1: 2nd shut-down route STO/SIL3 is used</p> <p>Input STO1-ENABLE has no function, do not wire the connection</p> <p>Referenced to earth: Always connect XGND (X4B/5) to I/O-GND on the control system</p>
	<p>Application: PMCprotego S1: 2nd shut-down route is not used PMCprotego S2: Does not have a 2nd shutdown route</p> <p>Connect 24 VDC</p> <p>Referenced to earth: Always connect XGND (X4B/5) to I/O-GND on the control system</p>

6.7.3 Digital outputs

Connector X3A/X3B	Pin	Designation	Description
	6	DIGITAL-INOUT 1	Digital input or output 1
	7	DIGITAL-INOUT 2	Digital input or output 2
	8	24 V	Supply voltage for digital outputs
	14	BTB/RTO	Relay contact for operational readiness, servo amplifier
	15	BTB/RTO	Relay contact for operational readiness, servo amplifier
	16	DGND	Reference earth for digital inputs or outputs

Connector pin assignment

Output circuit	Digital output
	<p>24 VDC</p> <p>Referenced to earth: Always connect DGND (X3B/16) to I/O-GND on the control system</p> <p>Pins 6 and 7 are configured as digital outputs in the commissioning software</p>
	<p>Relay contact for operational readiness, servo amplifier</p>

Connection

6.7.4 Analogue inputs

Connector X3A/X3B	Pin	Designation	Description
	9	ANALOG-IN1-	Analogue input 1-
	10	ANALOG-IN1+	Analogue input 1+
	11	ANALOG-IN2-	Analogue input 2-
	12	ANALOG-IN2+	Analogue input 2+
	13	AGND	Reference earth for analogue inputs

Connector pin assignment

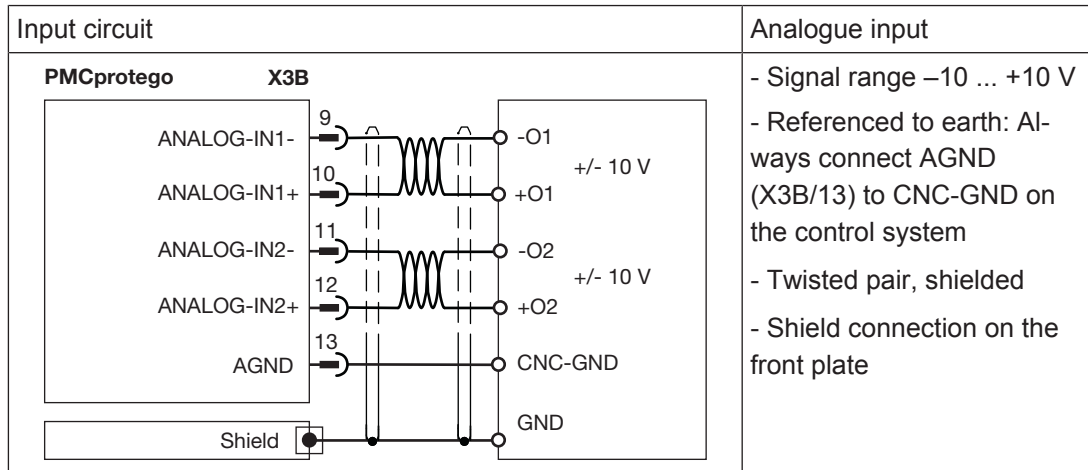

Connection

6.7.5 Encoder systems

6.7.5.1 HIPERFACE DSL, one-cable connection

Under "Connection cables", please note the requirements for the:

- ▶ Cable cross sections
- ▶ Insulation material



NOTICE

The connection cable must not exceed the maximum length of 25 m.
The connection cable must not be interrupted or separated.

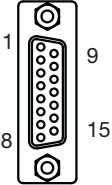
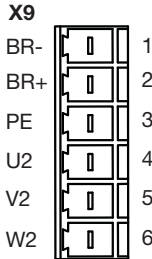
One-cable connection (Performance and feedback)	Pin	Designation	Description
Connector X1 Connection feedback			
 Connector with electronics	1	n. c.	--
	2	0 V	Supply voltage 0 V
	3	n. c.	--
	4	Up	Supply voltage for encoder 7.5 - 11 V DC
	5	n. c.	--
	6	n. c.	--
	7	n. c.	--
	8	DSL+	DSL+
	9	n. c.	--
	10	n. c.	--
	11	n. c.	--
	12	n. c.	--
	13	n. c.	--
	14	n. c.	--
	15	DSL-	DSL-
	n. c.: Not connected		
Connector X9 Connection power			
	1	BR-	Brake-
	2	BR+	Brake+
	3	PE	Earth conductor
	4	U2	Motor connection phase U
	5	V2	Motor connection phase V
	6	W2	Motor connection phase W

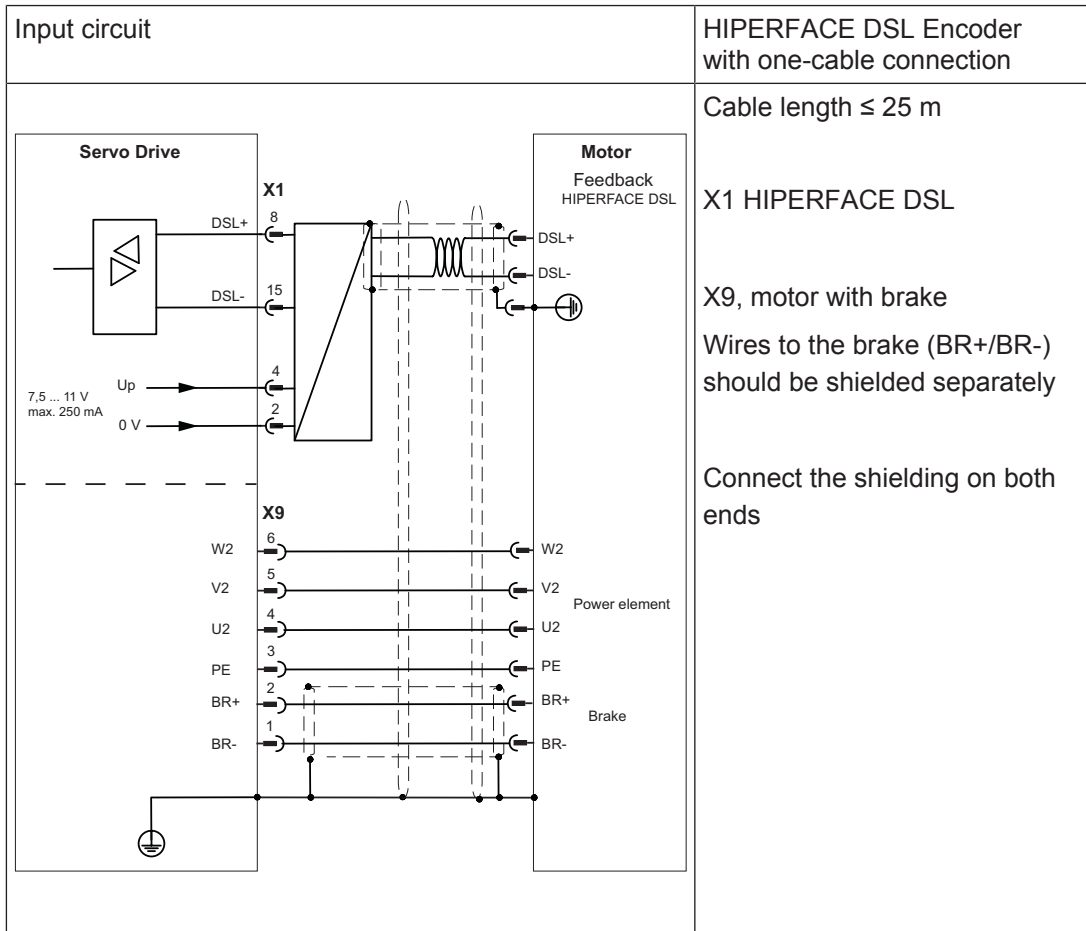

6.7.5.2 SFD3, one-cable connection

Information on the connection can be found in chapter [HIPERFACE DSL, one-cable connection](#) [129].

6.7.5.3 Resolver

Under “Connection cables”, please note the requirements for the:

- ▶ Cable cross sections
- ▶ Insulation material

If the cable length > 100 m, speak to our Customer Support.

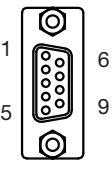
Connector X2	Pin	Designation	Description
	1	Shield	Internal shield
	2	ϑ	Thermal switch (+)
	3	S4	Sine input
	4	S3	Cosine input
	5	R2	Reference output
	6	ϑ	Thermal switch (-)
	7	S2	Sine input
	8	S1	Cosine input
	9	R1	Reference output

Connector pin assignment

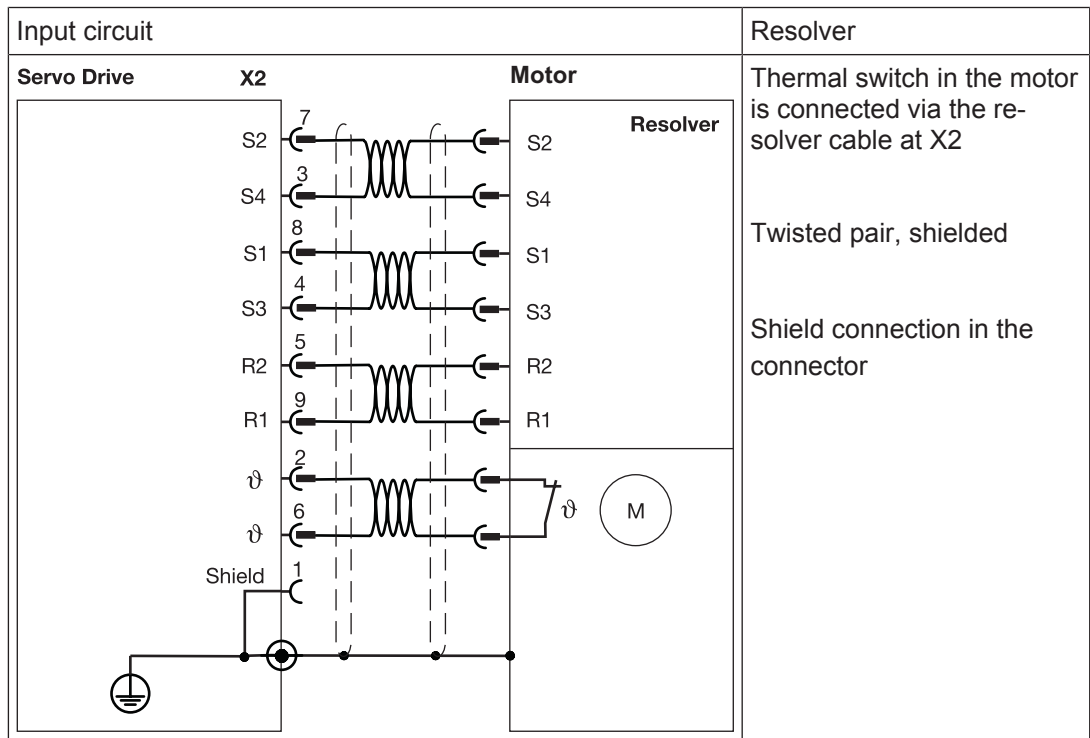

Connection

6.7.5.4 SinCos encoder with HIPERFACE interface

Under “Connection cables”, please note the requirements for the:

- ▶ Cable cross sections
- ▶ Insulation material

If the cable length is > 50 m, please speak to our Customer Support.

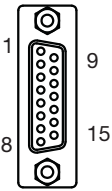
Connector X1	Pin	Designation	Description
	1	+SIN	Sine +
	2	0 V	Supply voltage 0 V
	3	+COS	Cosine +
	4	Up	Supply voltage for encoder 7 - 12 VDC
	5	Data+ (RS 485)	Parameter channel RS 485
	6	n. c.	--
	7	ϑ	Thermal switch (+)
	8	n. c.	--
	9	REFSIN	Reference sine
	10	n. c.	--
	11	REFCOS	Reference cosine
	12	n. c.	--
	13	Data- (RS 485)	Parameter channel RS 485
	14	ϑ	Thermal switch (-)
	15	n. c.	--
n. c.: Not connected			

Connector pin assignment

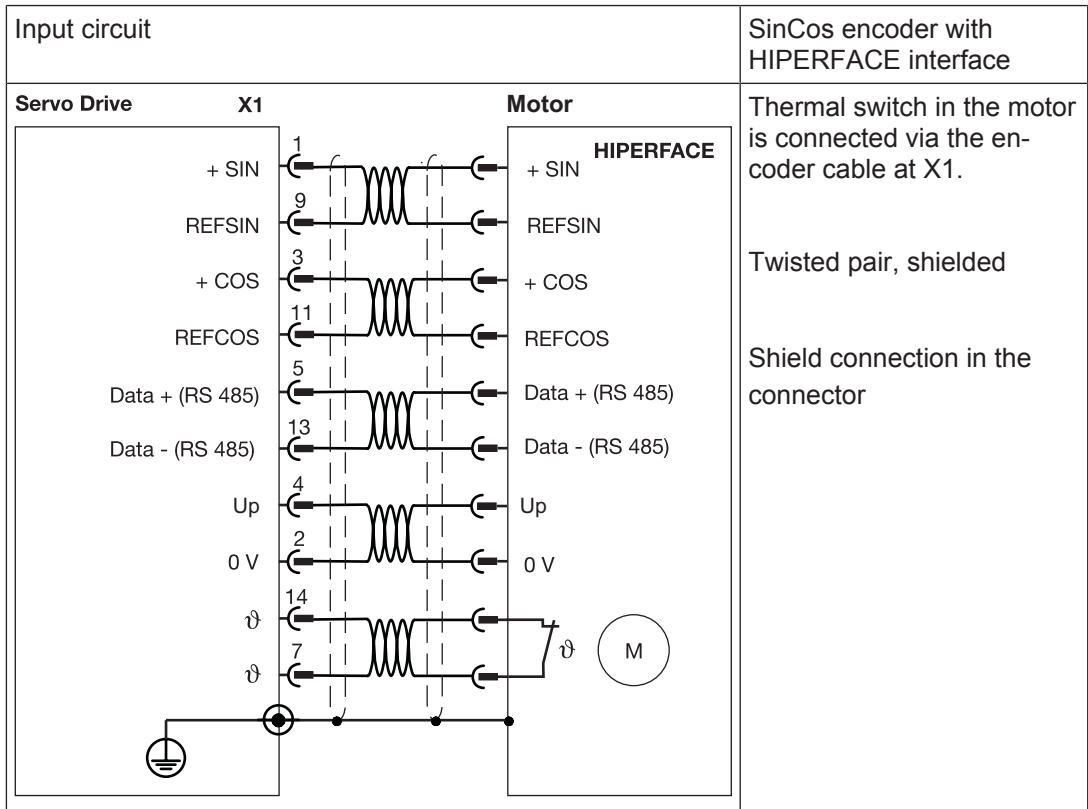

Connection

6.7.5.5 SinCos encoder with EnDat 2.1 interface

Under “Connection cables”, please note the requirements for the:

- ▶ Cable cross sections
- ▶ Insulation material

If the cable length is > 50 m, please speak to our Customer Support.

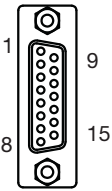
Connector X1	Pin	Designation	Description
	1	B-	Channel B (cosine) inverted
	2	0 V	Supply voltage 0 V
	3	A-	Channel A (sine) inverted
	4	Up	Supply voltage for encoder
	5	DATA	Data
	6	n. c.	--
	7	ϑ	Thermal switch (+)
	8	CLOCK	Test pulse output
	9	B+	Channel B (cosine)
	10	Sense 0 V	Supply voltage feedback 0 V
	11	A+	Channel A (sine)
	12	Sense Us	Supply voltage feedback +5 V
	13	DATA\	Data inverted
	14	ϑ	Thermal switch (-)
	15	CLOCK\	Test pulse output inverted
n. c.: Not connected			

Connector pin assignment

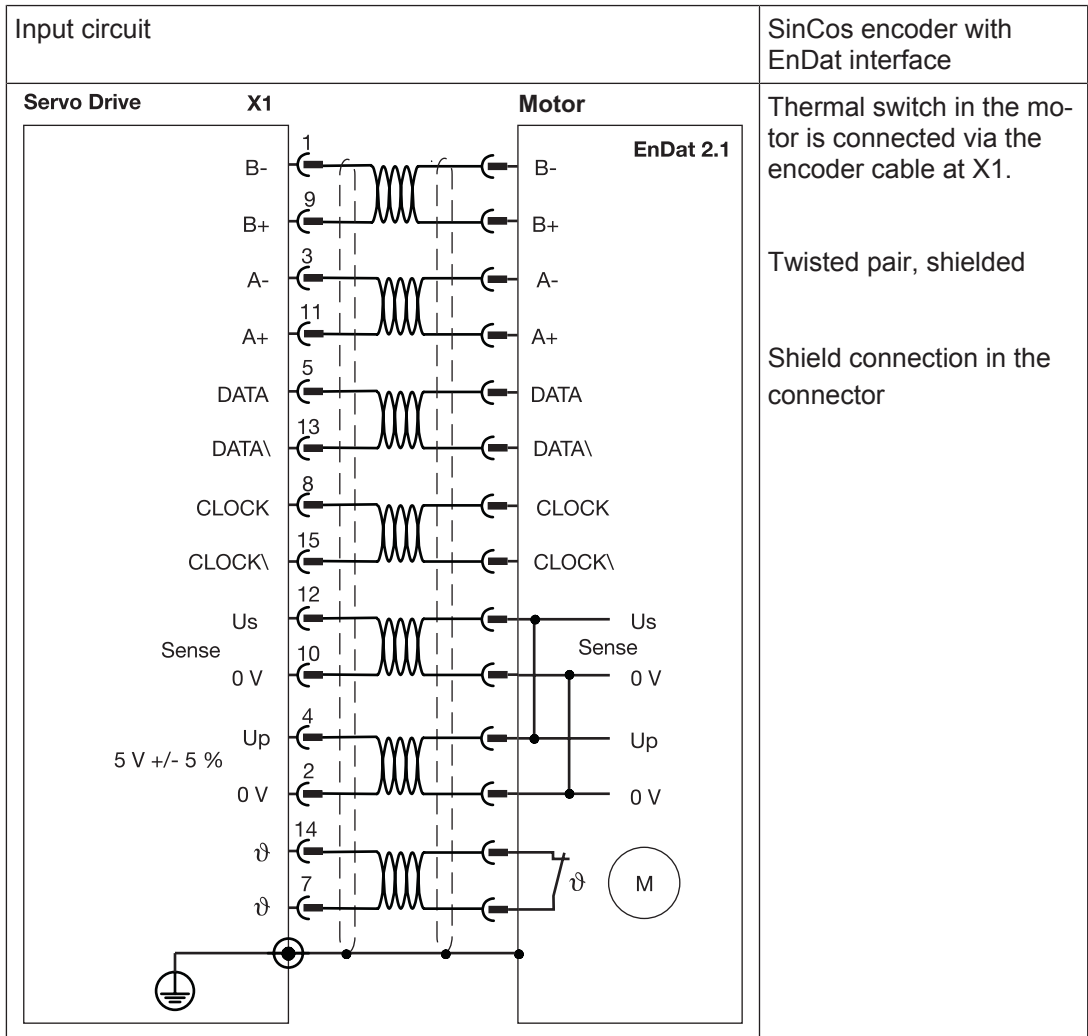

Connection

6.7.5.6 Encoder with EnDat 2.2 interface

Under "Connection cables", please note the requirements for the:

- ▶ Cable cross sections
- ▶ Insulation material

If the cable length is > 50 m, please speak to our Customer Support.

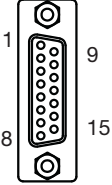
Connector X1	Pin	Designation	Description
	1	n. c.	--
	2	0 V	Supply voltage 0 V
	3	n. c.	--
	4	Up	Supply voltage for encoder
	5	DATA	Data
	6	n. c.	--
	7	ϑ	Thermal switch (+)
	8	CLOCK	Test pulse output
	9	n. c.	--
	10	Sense 0 V	Supply voltage feedback 0 V
	11	n. c.	--
	12	Sense Us	Supply voltage feedback
	13	DATA\	Data inverted
	14	ϑ	Thermal switch (-)
	15	CLOCK\	Test pulse output inverted
n. c.: Not connected			

Connector pin assignment



INFORMATION

The encoder supply voltage from 3.6 – 14 V can be operated without a sensor cable. (FBTYPE 34)

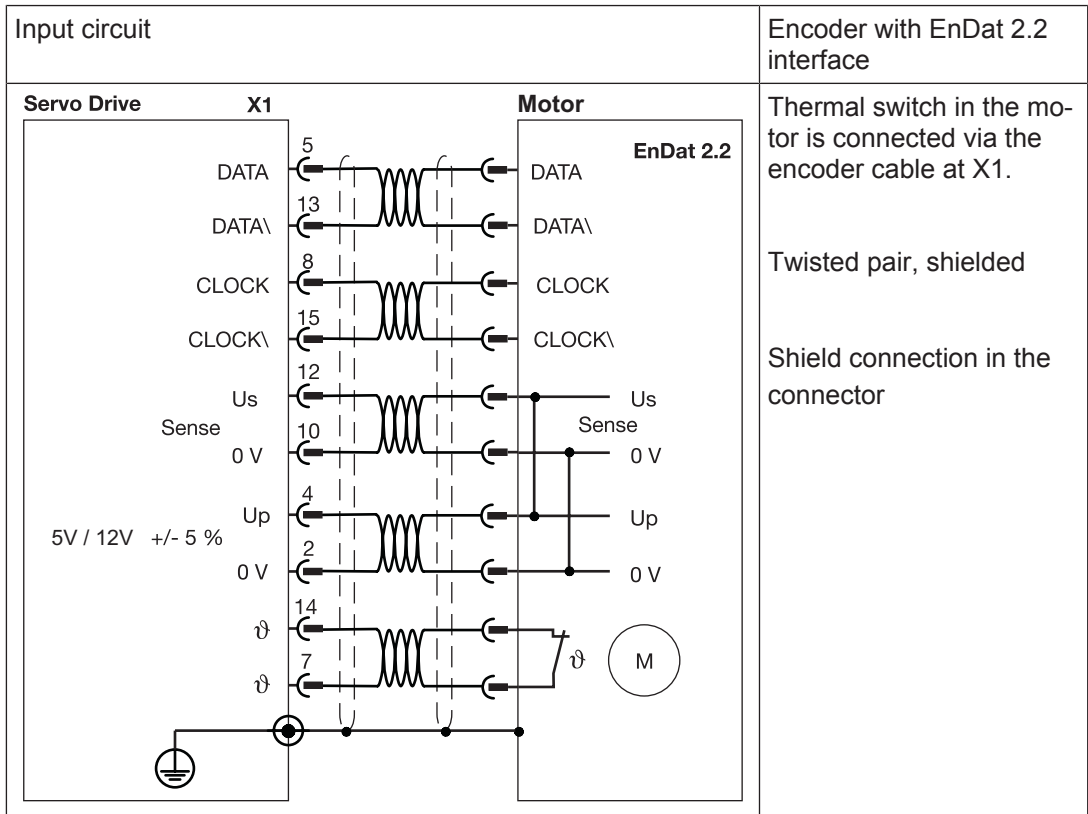

Connection



INFORMATION

The encoder supply voltage from 3.6 – 14 V can be operated without a sensor cable. (FBTYPE 34)

6.7.5.7 SinCos encoder with BISS interface, analogue

Under "Connection cables", please note the requirements for the:

- ▶ Cable cross sections
- ▶ Insulation material

If the cable length is > 50 m, please speak to our Customer Support.

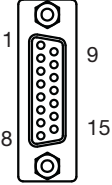
Connector X1	Pin	Designation	Description
	1	B-	Channel B (cosine) inverted
	2	0 V	Supply voltage 0 V
	3	A-	Channel A (sine) inverted
	4	Up	Supply voltage for encoder
	5	DATA	Data
	6	n. c.	--
	7	ϑ	Thermal switch (+)
	8	CLOCK	Test pulse output
	9	B+	Channel B (cosine)
	10	Sense 0 V	Supply voltage feedback 0 V
	11	A+	Channel A (sine)
	12	Sense Us	Supply voltage feedback +5 V
	13	DATA\	Data inverted
	14	ϑ	Thermal switch (-)
	15	CLOCK\	Test pulse output inverted
n. c.: Not connected			

Connector pin assignment

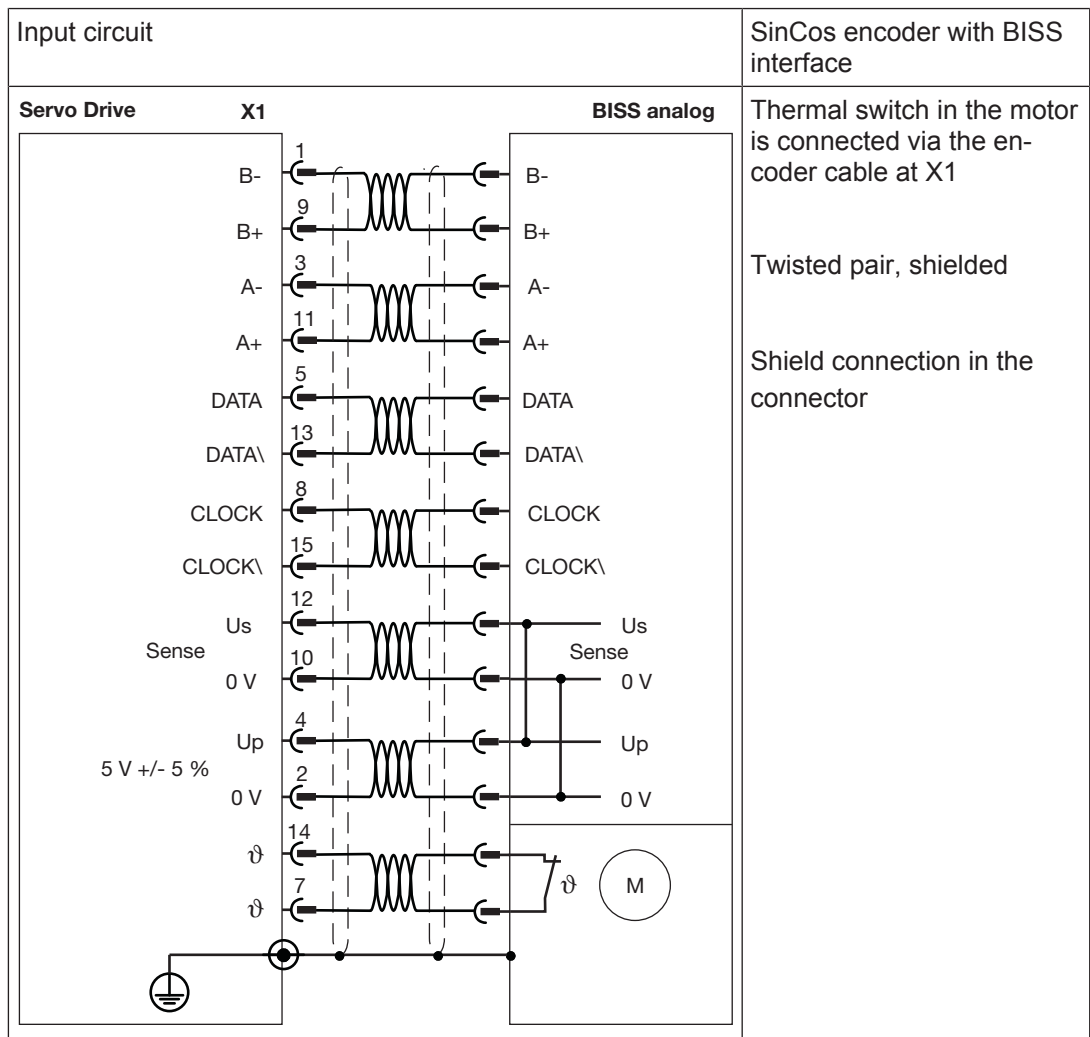

Connection

6.7.5.8 Encoder with BISS interface, digital

Under "Connection cables", please note the requirements for the:

- ▶ Cable cross sections
- ▶ Insulation material

If the cable length is > 50 m, please speak to our Customer Support.

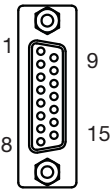
Connector X1	Pin	Designation	Description
	1	n. c.	--
	2	0 V	Supply voltage 0 V
	3	n. c.	--
	4	Up	Supply voltage for encoder
	5	DATA	Data
	6	n. c.	--
	7	ϑ	Thermal switch (+)
	8	CLOCK	Test pulse output
	9	n. c.	--
	10	Sense 0 V	Supply voltage feedback 0 V
	11	n. c.	--
	12	Sense Us	Supply voltage feedback +5 V
	13	DATA\	Data inverted
	14	ϑ	Thermal switch (-)
	15	CLOCK\	Test pulse output inverted
n. c.: Not connected			

Connector pin assignment

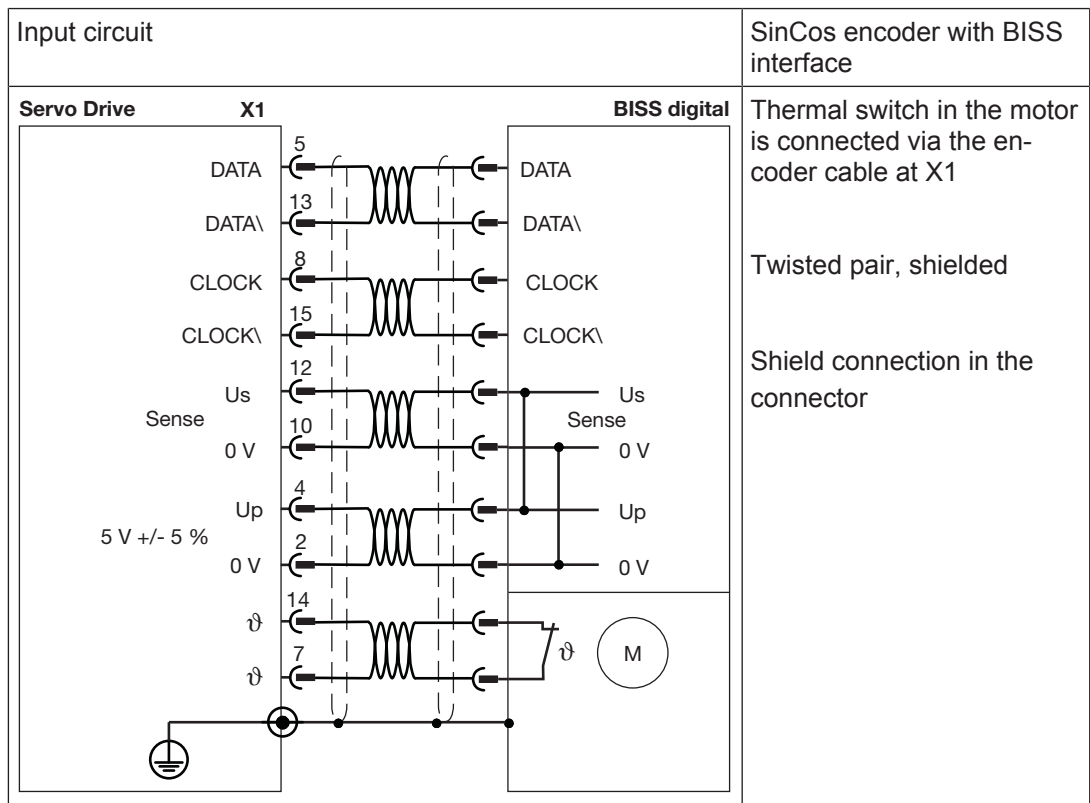

Connection

6.7.5.9 SinCos encoder with SSI interface

Under “Connection cables”, please note the requirements for the:

- ▶ Cable cross sections
- ▶ Insulation material

If the cable length is > 50 m, please speak to our Customer Support.

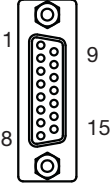
Connector X1	Pin	Designation	Description
	1	B-	Channel B (cosine) inverted
	2	0 V	Supply voltage 0 V
	3	A-	Channel A (sine) inverted
	4	Up	Supply voltage for encoder
	5	DATA	Data
	6	n. c.	--
	7	ϑ	Thermal switch (+)
	8	CLOCK	Test pulse output
	9	B+	Channel B (cosine)
	10	Sense 0 V	Supply voltage feedback 0 V
	11	A+	Channel A (sine)
	12	Sense Us	Supply voltage feedback +5 V
	13	DATA\	Data inverted
	14	ϑ	Thermal switch (-)
	15	CLOCK\	Test pulse output inverted
n. c.: Not connected			

Connector pin assignment

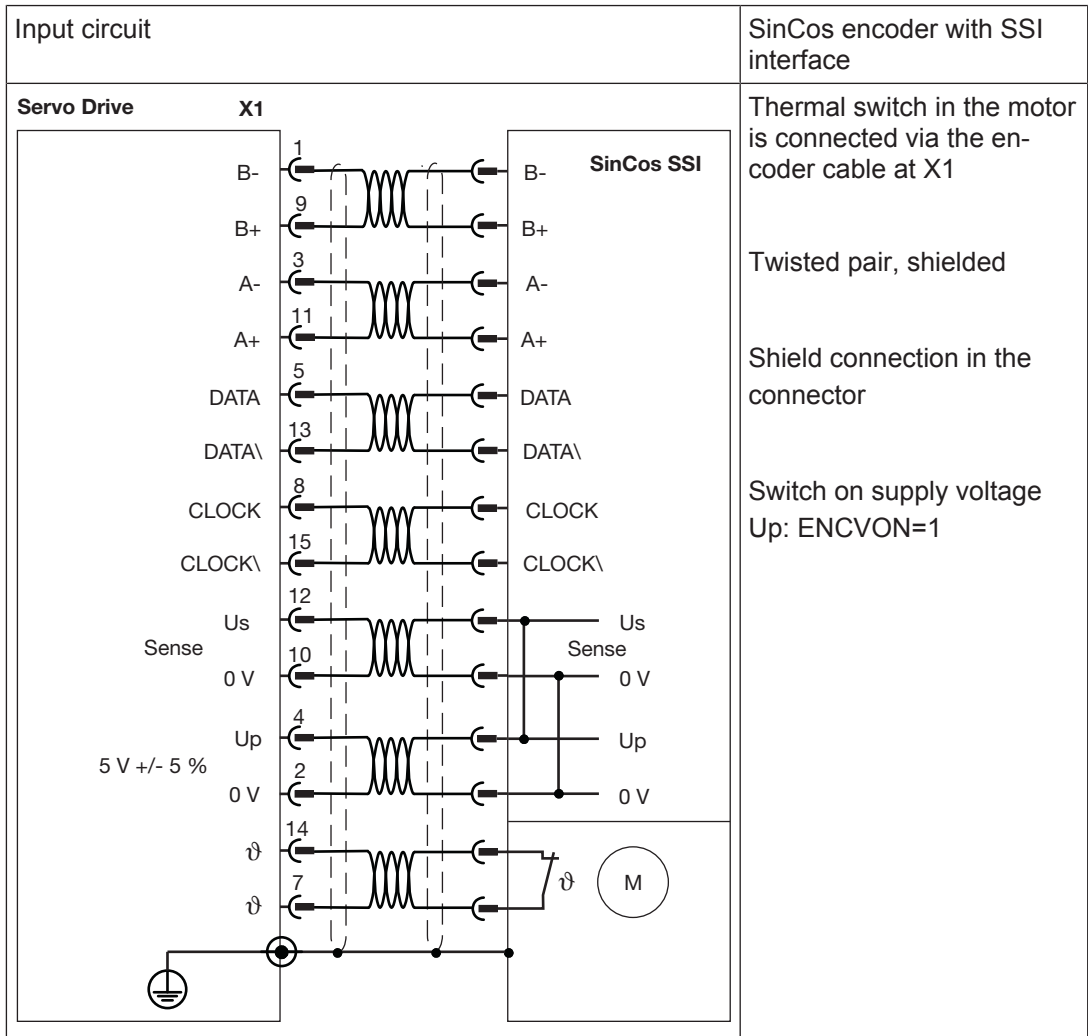

Connection

6.7.5.10 SinCos encoder without data track

Under "Connection cables", please note the requirements for the:

- ▶ Cable cross sections
- ▶ Insulation material

If the cable length is > 50 m, please speak to our Customer Support.

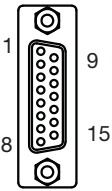
Connector X1	Pin	Designation	Description
	1	B-	Cosine -
	2	0 V	Supply voltage 0 V
	3	A-	Sine -
	4	Up	Supply voltage
	5	NI+	Zero pulse +
	6	n. c.	--
	7	ϑ	Thermal switch (+)
	8	n. c.	--
	9	B+	Cosine +
	10	Sense 0 V	Supply voltage 0 V
	11	A+	Sine +
	12	Sense Us	Supply voltage
	13	NI-	Zero pulse -
	14	ϑ	Thermal switch (-)
	15	n. c.	--
n. c.: Not connected			

Connector pin assignment

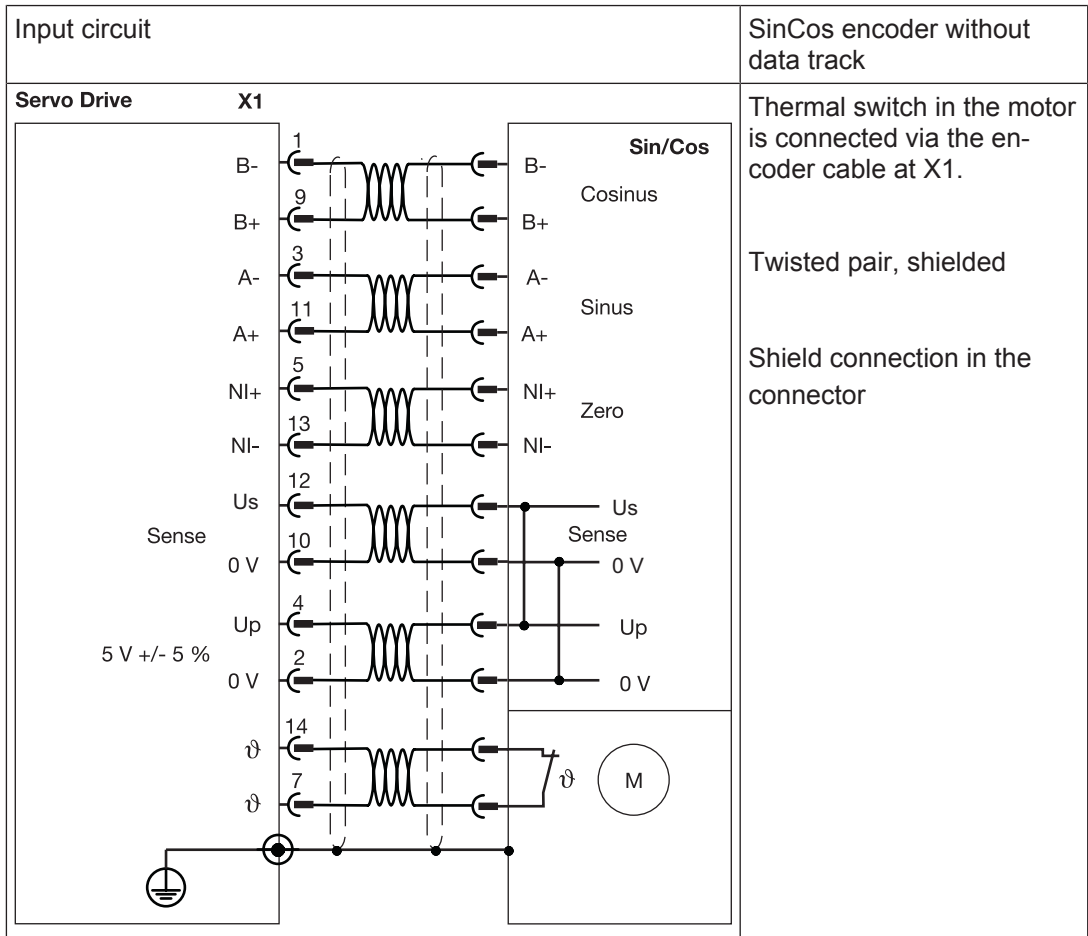

Connection

6.7.5.11 SinCos encoder with Hall encoder

Under "Connection cables", please note the requirements for the:

- ▶ Cable cross sections
- ▶ Insulation material

If the cable length is > 25 m, please speak to our Customer Support.

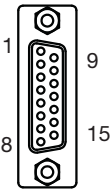
Connector X1	Pin	Designation	Description
	1	B-	Cosine -
	2	0 V	Supply voltage 0 V
	3	A-	Sine-
	4	Up	Supply voltage
	5	NI+	Zero pulse +
	6	Hall-U	Hall-U
	7	ϑ	Thermal switch (+)
	8	Hall-V	Hall-V
	9	B+	Cosine +
	10	Sense 0 V	Supply voltage 0 V
	11	A+	Sine +
	12	Sense Us	Supply voltage
	13	NI-	Zero pulse -
	14	ϑ	Thermal switch (-)
	15	Hall-W	Hall-W

Connector pin assignment

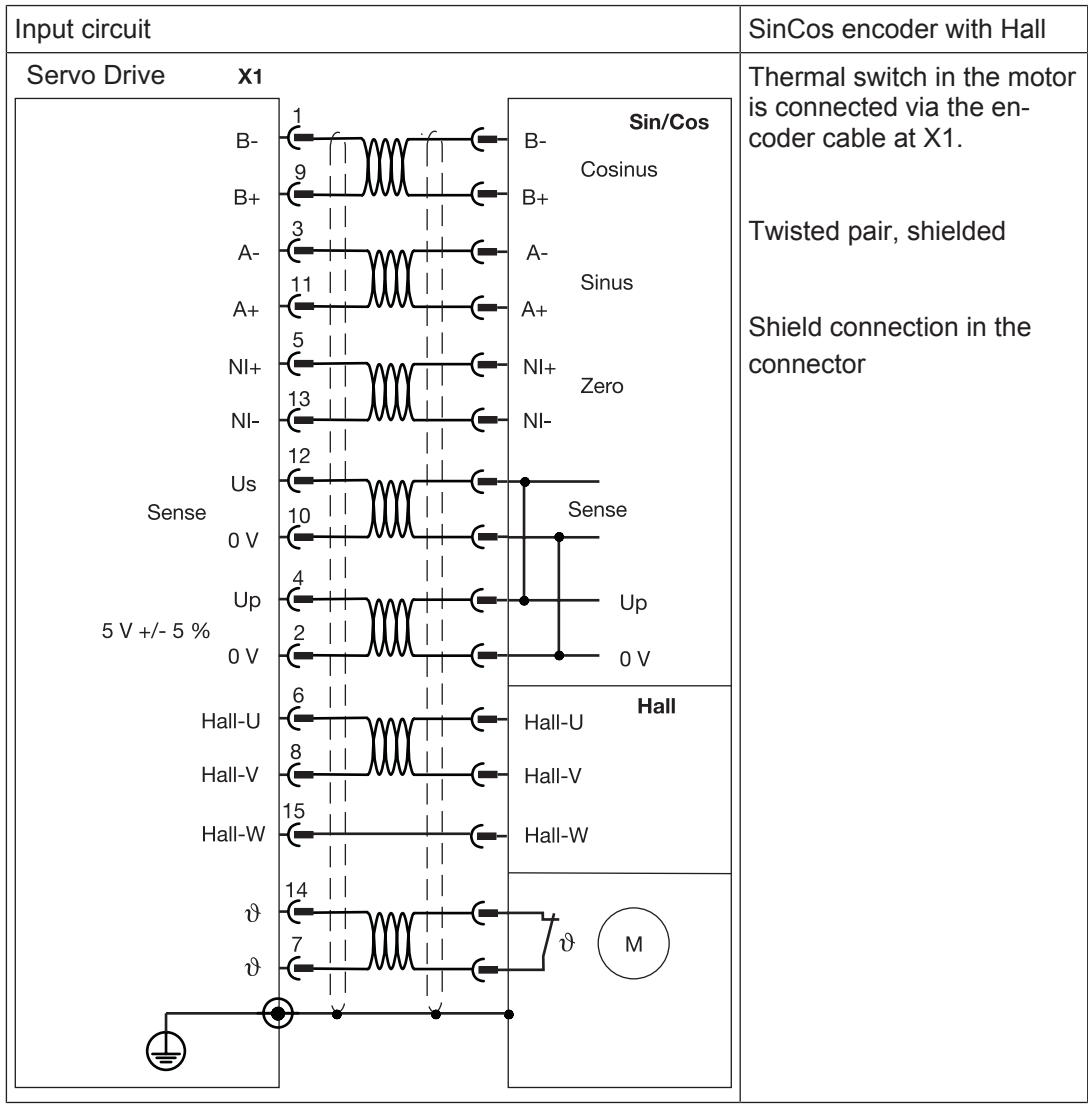

Connection

6.7.5.12 Incremental encoder ROD (AquadB) 5 V, 350 kHz

Under "Connection cables", please note the requirements for the:

- ▶ Cable cross sections
- ▶ Insulation material

If the cable length is > 50 m, please speak to our Customer Support.

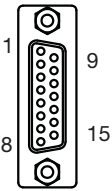
Connector X1	Pin	Designation	Description
	1	B	Channel B
	2	0 V	Supply voltage 0 V
	3	A	Channel A
	4	Up	Supply voltage 5 V
	5	T	Reference pulse
	6	n. c.	--
	7	ϑ	Thermal switch (+)
	8	n. c.	--
	9	B\.	Channel B inverted
	10	Sense 0 V	Supply voltage feedback 0 V
	11	A\	Channel A inverted
	12	Sense Us	Supply voltage feedback 5 V
	13	Z\	Reference pulse inverted
	14	ϑ	Thermal switch (-)
	15	n. c.	--
n. c.: Not connected			

Connector pin assignment

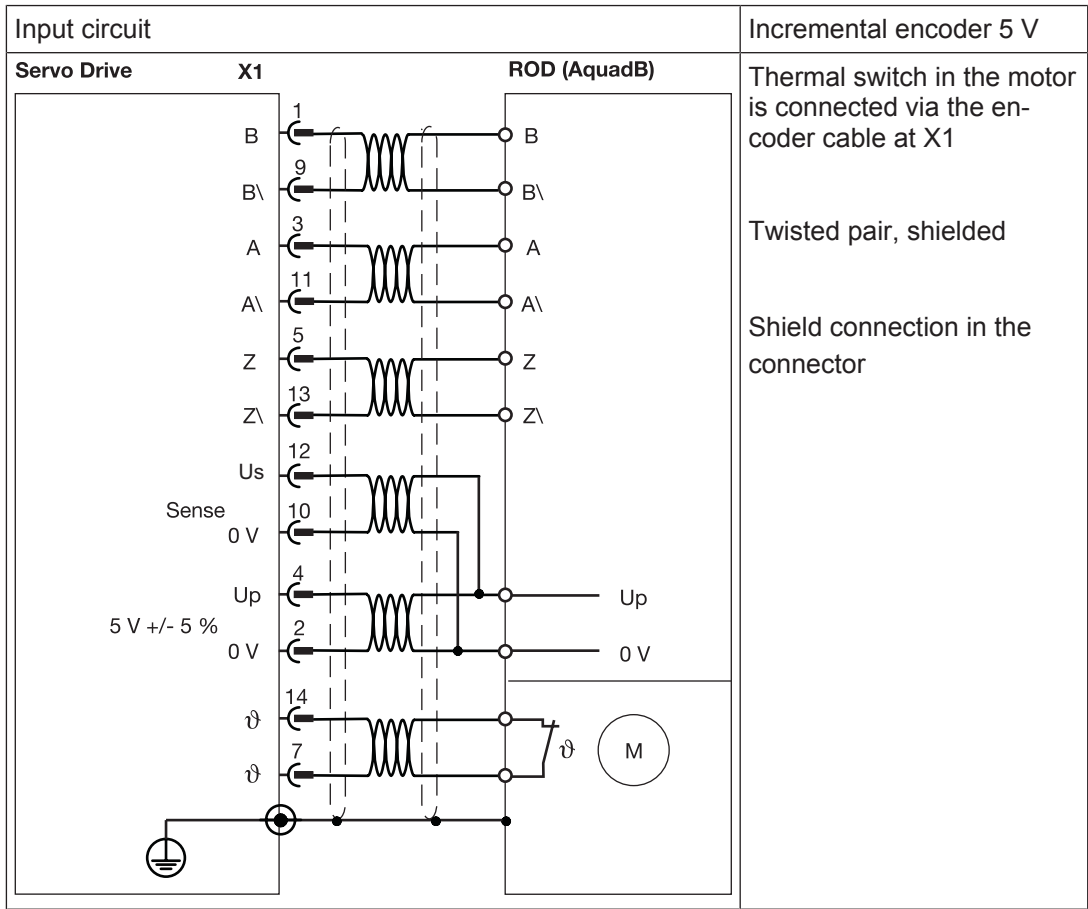

Connection

6.7.5.13 Incremental encoder ROD (AquadB) 5 V, 1.5 MHz

Under "Connection cables", please note the requirements for the:

- ▶ Cable cross sections
- ▶ Insulation material

If the cable length is > 50 m, please speak to our Customer Support.

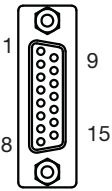
Connector X1	Pin	Designation	Description
	1	n. c.	--
	2	0 V	Supply voltage 0 V
	3	n. c.	--
	4	Up	Supply voltage 5 V
	5	B	Channel B
	6	n. c.	--
	7	ϑ	Thermal switch (+)
	8	A	Channel A
	9	n. c.	--
	10	Sense 0 V	Supply voltage feedback 0 V
	11	n. c.	--
	12	Sense Us	Supply voltage feedback 5 V
	13	B\	Channel B inverted
	14	ϑ	Thermal switch (-)
	15	A\	Channel A inverted
n. c.: Not connected			

Connector pin assignment

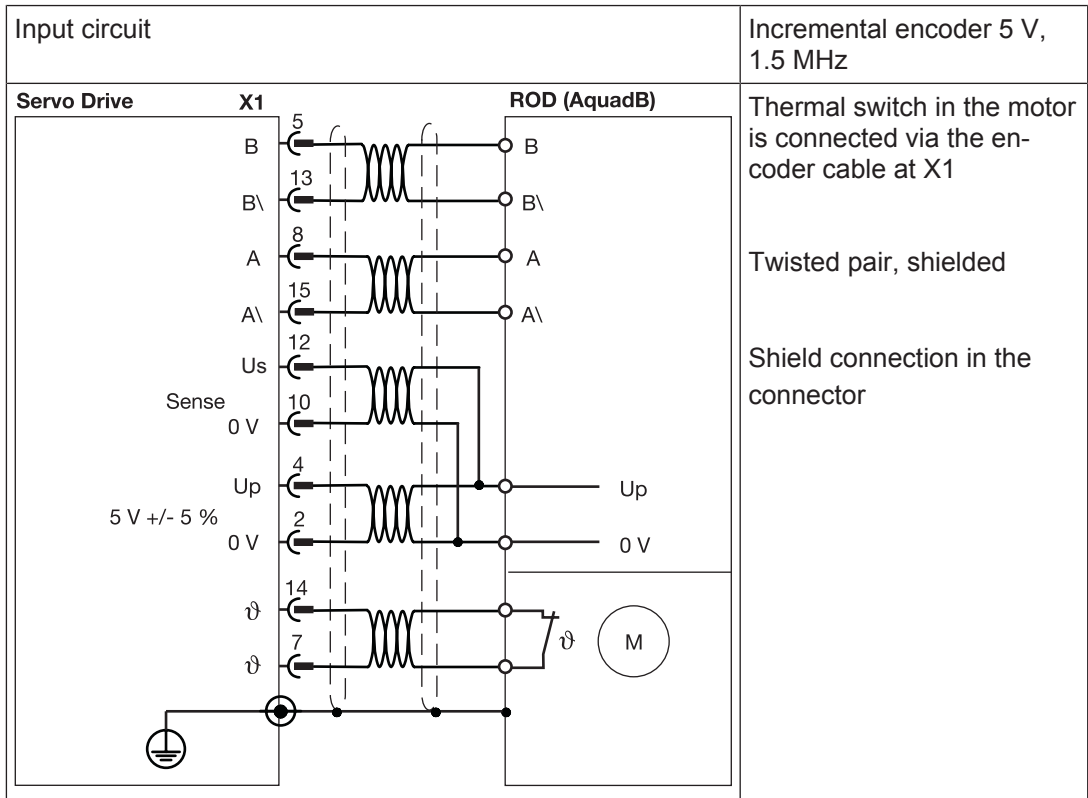

Connection

6.7.5.14 Incremental encoder ROD (AquadB) 5 V, with zero pulse, with Hall encoder

Under "Connection cables", please note the requirements for the:

- ▶ Cable cross sections
- ▶ Insulation material

If the cable length is > 25 m, please speak to our Customer Support.

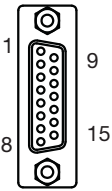
Connector X1	Pin	Designation	Description
	1	B	Channel B
	2	0 V	Supply voltage 0 V
	3	A	Channel A
	4	Up	Supply voltage 5 V
	5	T	Reference pulse
	6	Hall-U	Hall-U
	7	ϑ	Thermal switch (+)
	8	Hall-V	Hall-V
	9	B\.	Channel B inverted
	10	Sense 0 V	Supply voltage feedback 0 V
	11	A\	Channel A inverted
	12	Sense Us	Supply voltage feedback 5 V
	13	Z\	Reference pulse inverted
	14	ϑ	Thermal switch (-)
	15	Hall-W	Hall-W
n. c.: Not connected			

Connector pin assignment

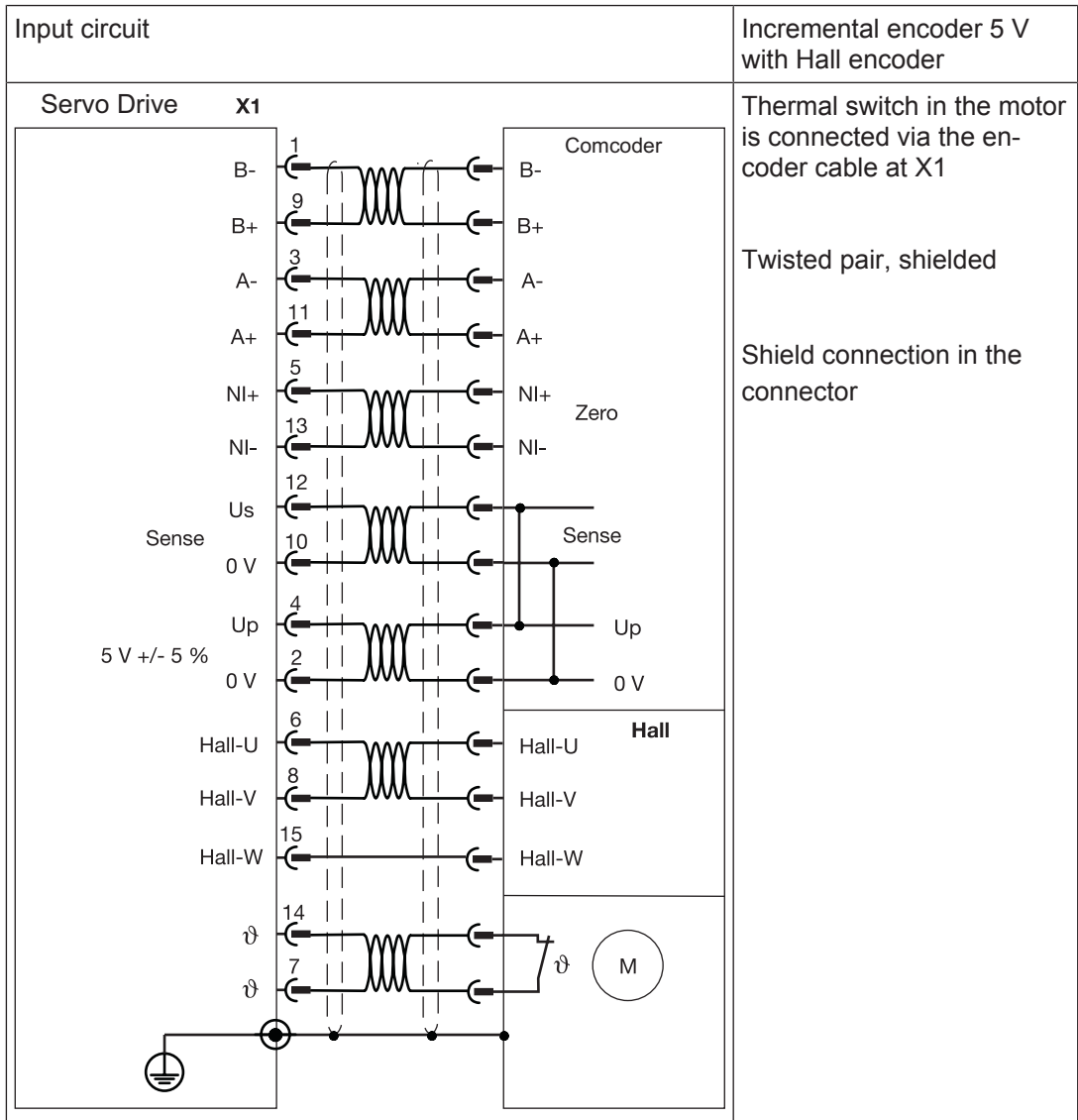

Connection

6.7.5.15 Incremental encoder ROD (AquadB) 24 V, without zero pulse

Under “Connection cables”, please note the requirements for the:

- ▶ Cable cross sections
- ▶ Insulation material

If the cable length is > 25 m, please speak to our Customer Support.

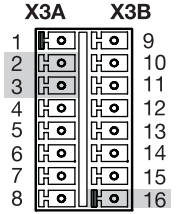
Connector X3A/X3B	Pin	Designation	Description
	2	DIGITAL-IN1	Track A
	3	DIGITAL-IN2	Track B
	16	DGND	Reference earth for digital inputs

Connector pin assignment

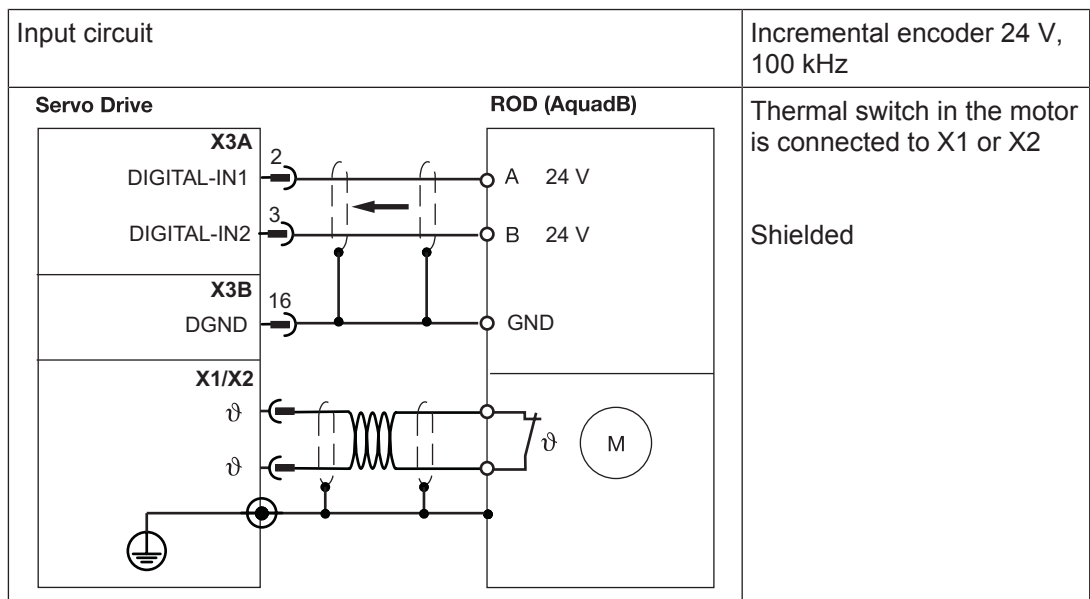

Connection

6.7.5.16 Incremental encoder ROD (AquadB) 24 V, without zero pulse, with Hall encoder

Under “Connection cables”, please note the requirements for the:

- ▶ Cable cross sections
- ▶ Insulation material

If the cable length is > 25 m, please speak to our Customer Support.

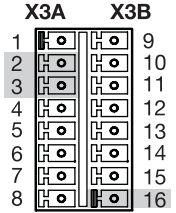
Connector X3A/X3B	Pin	Designation	Description
	2	DIGITAL-IN1	Track A
	3	DIGITAL-In2	Track B
	16	DGND	Reference earth for digital inputs

Connector pin assignment

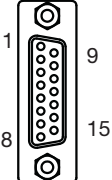
Connector X1	Pin	Designation	Description
	1	n c	-
	2	0 V	Supply voltage 0 V
	3	n c	-
	4	Up	Supply voltage 5 V
	5	n c	-
	6	Hall-U	Hall-U
	7	ϑ	Thermal switch (+)
	8	Hall-V	Hall-V
	9	n c	-
	10	Sense 0 V	Supply voltage feedback 0 V
	11	n c	-
	12	Sense Up.	Supply voltage feedback 5 V
	13	n c	-
	14	ϑ	Thermal switch (-)
	15	Hall-W	Hall-W
n. c.: Not connected			

Connector pin assignment

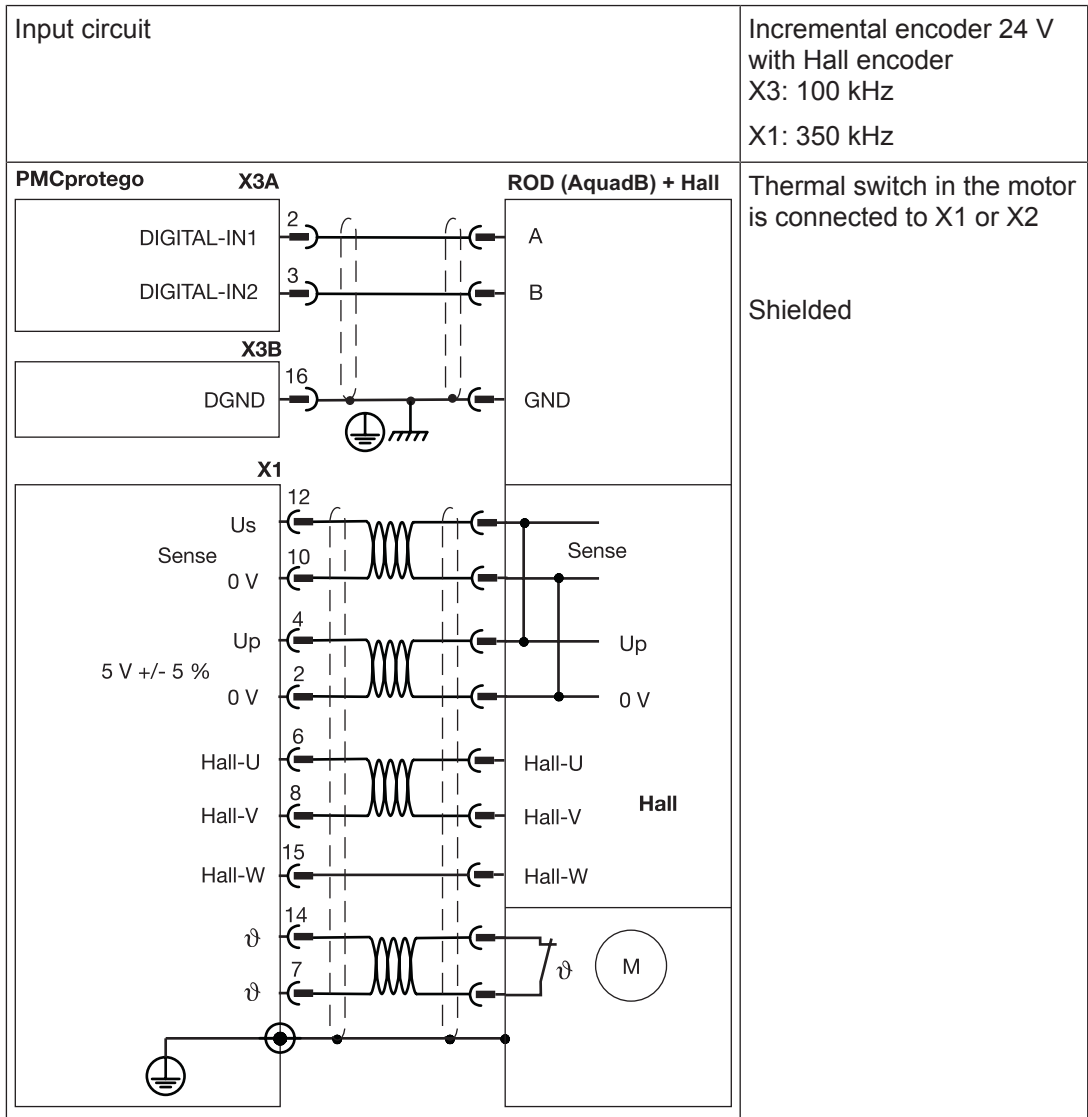

Connection

6.7.5.17 Absolute encoder with SSI interface

Under "Connection cables", please note the requirements for the:

- ▶ Cable cross sections
- ▶ Insulation material

If the cable length is > 50 m, please speak to our Customer Support.

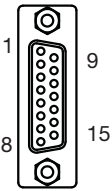
Connector X1	Pin	Designation	Description
	1	n. c.	--
	2	0 V	Supply voltage 0 V
	3	n. c.	--
	4	Up	Supply voltage for encoder
	5	DATA	Data
	6	n. c.	--
	7	ϑ	Thermal switch (+)
	8	CLOCK	Test pulse output
	9	n. c.	--
	10	Sense 0 V	Supply voltage feedback 0 V
	11	n. c.	--
	12	Sense Us	Supply voltage feedback +5 V
	13	DATA\	Data inverted
	14	ϑ	Thermal switch (-)
	15	CLOCK\	Test pulse output inverted
n. c.: Not connected			

Connector pin assignment

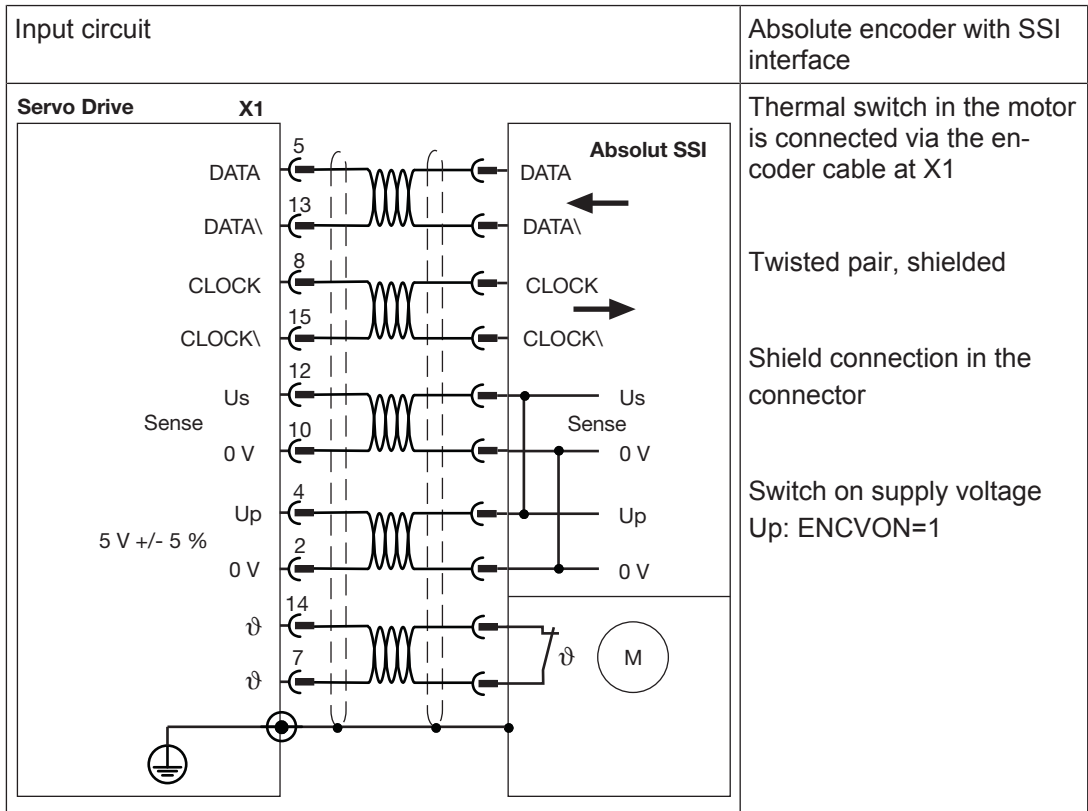

Connection

6.7.5.18 Hall encoder

Under “Connection cables”, please note the requirements for the:

- ▶ Cable cross sections
- ▶ Insulation material

If the cable length is > 25 m, please speak to our Customer Support.

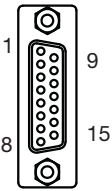
Connector X1	Pin	Designation	Description
	1	n. c.	-
	2	0 V	Supply voltage 0 V
	3	n. c.	-
	4	Up	Supply voltage
	5	n. c.	-
	6	Hall-U	Hall-U
	7	ϑ	Thermal switch (+)
	8	Hall-V	Hall-V
	9	n. c.	-
	10	0 V	Supply voltage 0 V
	11	n. c.	-
	12	Us	Supply voltage
	13	n. c.	-
	14	ϑ	Thermal switch (-)
	15	Hall-W	Hall-W
n. c. not connected			

Connector pin assignment

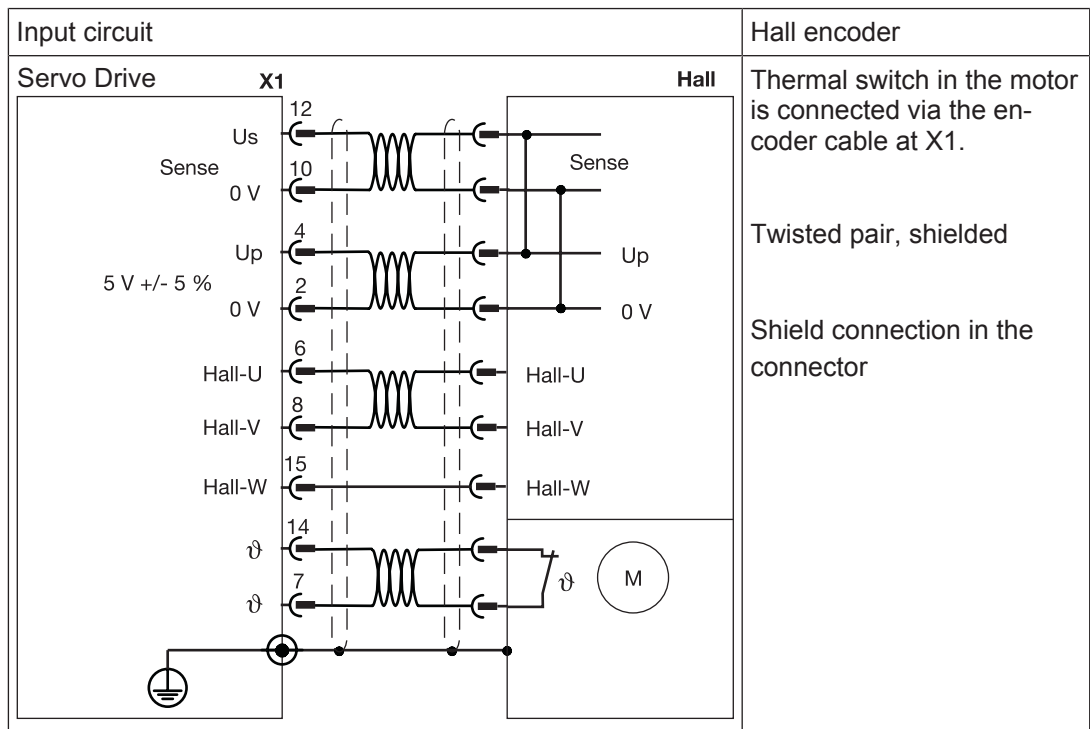

Connection

6.7.5.19 Electronic gearing, Master-Slave mode
Connection to a stepper motor control system with 5 V signal

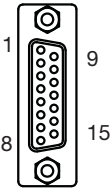
Connector X1	Pin	Designation	Description
	2	0 V	Supply voltage 0 V
	5	DIR+	Direction
	8	PULS+	Pulse
	13	DIR-	Direction inverted
	15	PULS-	Pulse inverted

Connector pin assignment

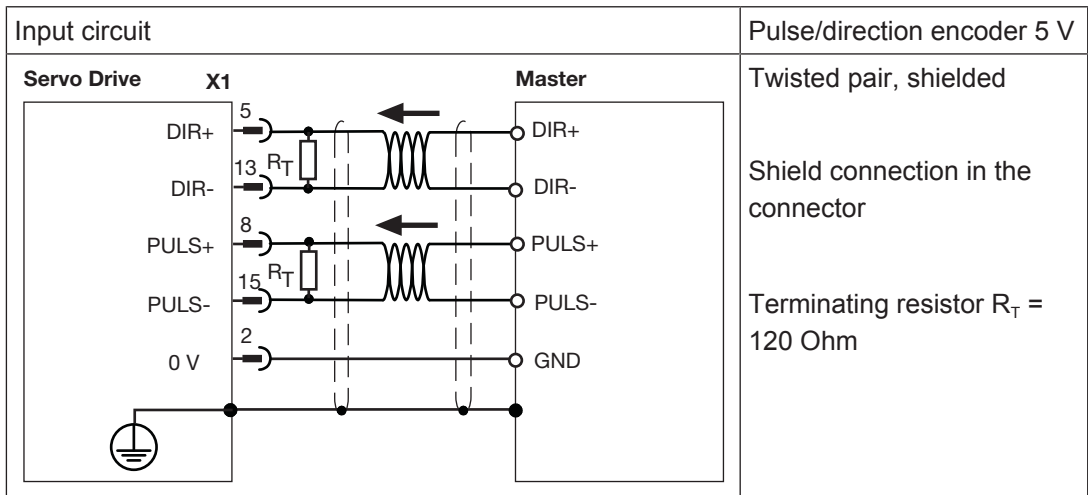

Connection

Connection to a stepper motor control system with 24 V signal

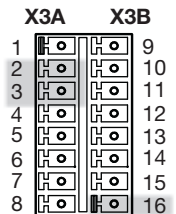
Connector X3	Pin	Designation	Description
	2	DIGITAL-IN1	Input for direction
	3	DIGITAL-IN2	Input for pulse
	16	DGND	Reference earth for digital inputs

Connector pin assignment

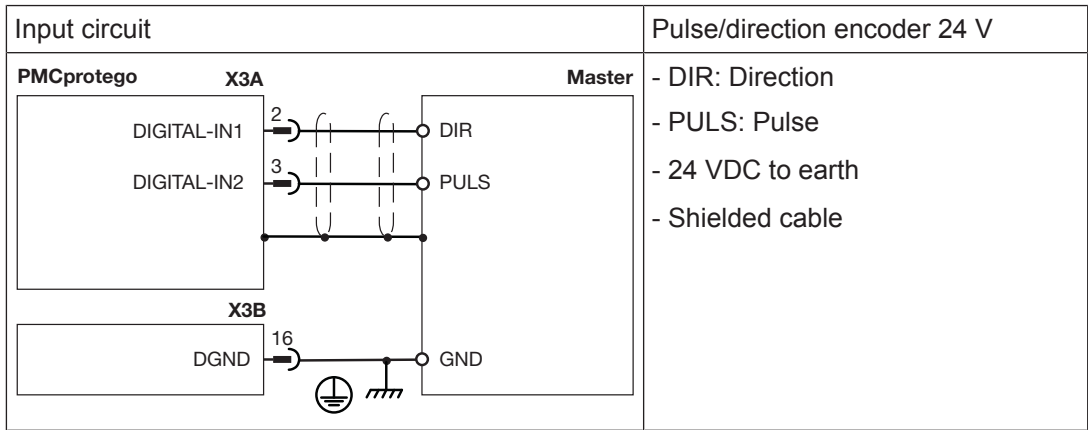

Connection

Master-Slave mode

Connector X1	Pin	Designation	Description
	2	0 V	Supply voltage 0 V
	5	A	Channel A
	8	B	Channel B
	13	A\	Channel A inverted
	15	B\	Channel B inverted

Connector pin assignment

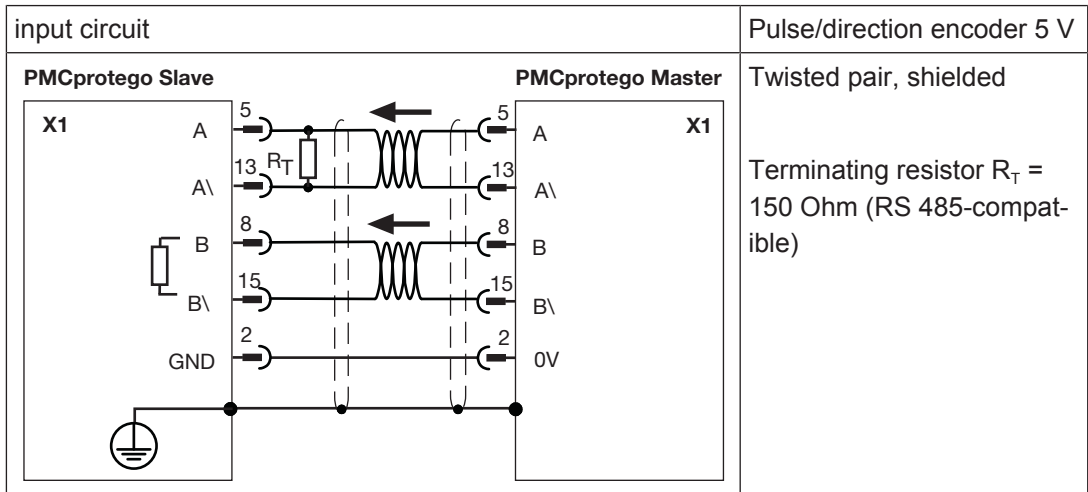

Connection

6.7.5.20 Encoder emulation
Output of incremental encoder signals

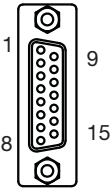
Connector X1	Pin	Designation	Description
	2	GND	Earth
	3	NI	Zero pulse
	5	B	Channel B
	8	A	Channel A
	11	NI\	Zero impulse inverted
	13	B\	Channel B inverted
	15	A\	Channel A inverted

Connector pin assignment

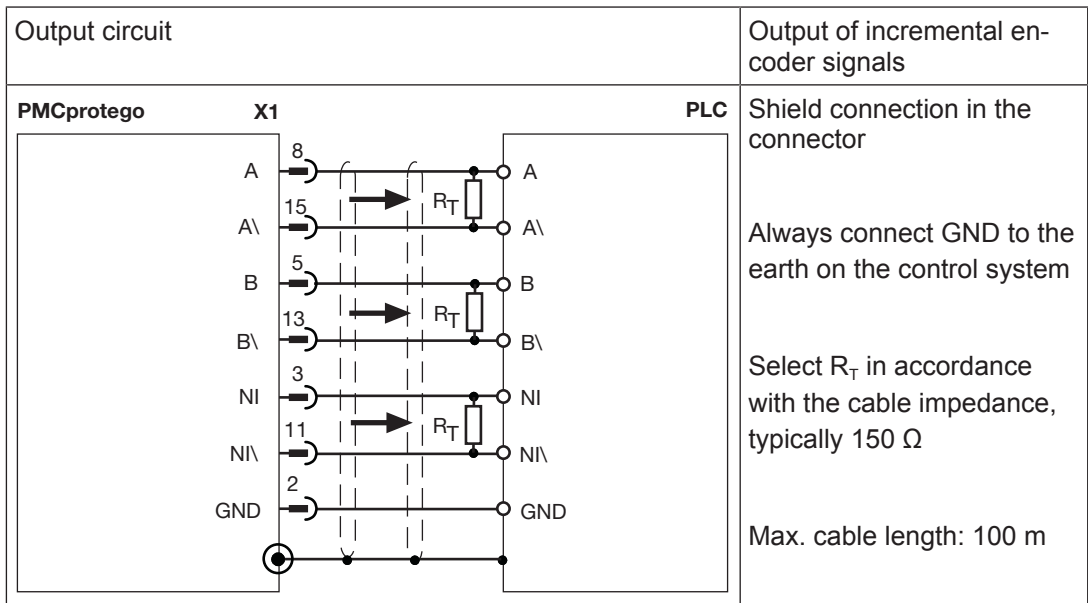

Connection

Output of SSI signals

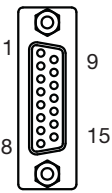
Connector X1	Pin	Designation	Description
	2	GND	Ground
	5	DATA	Data
	8	CLOCK	Pulse signal
	13	DATA\	Data inverted
	15	CLOCK	Pulse signal inverted

Connector pin assignment

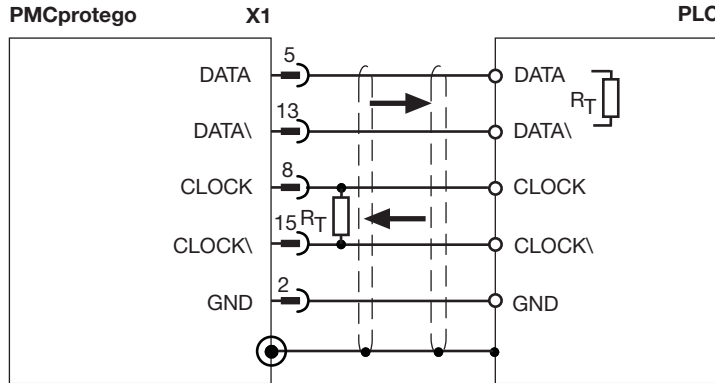
Output circuit	Output of SSI signals
	<p>Shield connection in the connector</p> <p>Always connect GND to the earth on the control system</p> <p>Select RT in accordance with the cable impedance, typically 150 Ω</p>

Connection

6.7.6 Communications interfaces

6.7.6.1 RS232 interface

We recommend shielded cable for the RS 232 interface.

If you use unshielded cables, the interface may malfunction.

- ▶ Earth the cable shielding on both sides (e.g. on a bus bar).
- ▶ Transient currents can be anticipated on longer cables. If this is the case you should use equipotential bonding cables.
- ▶ With the supply voltages switched off, connect the interface (X6) on the servo amplifier to a serial interface on the PC via a null modem cable.



INFORMATION

Do not use a null modem link cable!

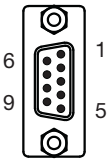
Connector X6	Pin	Designation	Description
	2	RxD	Receive data
	3	TxD	Send data
	5	GND	Ground

Connector pin assignment

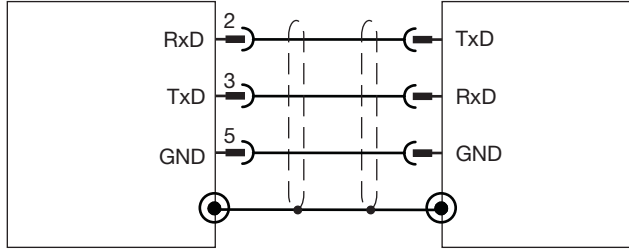
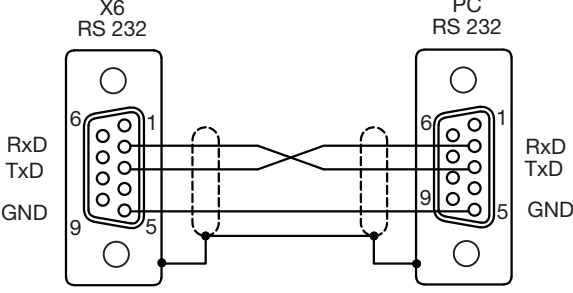
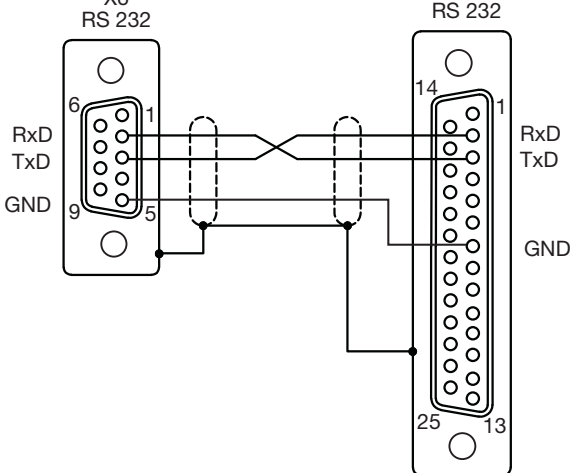
Port	RS232
<p>Servo Drive X6</p> 	<p>Shielded cable</p> <p>Shield connection on a bus bar</p> <p>The interface is on the same connector as the CANopen interface.</p> <p>The RS232 and CANopen interface use the same operating earth (GND).</p>
<p>X6 RS 232</p> 	<p>Cable:</p> <p>9-pin female D-Sub connector (servo amplifier) to 9-pin female D-Sub connector (PC)</p>
<p>X6 RS 232</p> 	<p>Cable:</p> <p>9-pin female D-Sub connector (servo amplifier) to 25-pin female D-Sub connector (PC)</p>

Connection

6.7.6.2 CANopen interface

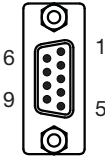
Connector X6	Pin	Designation	Description
	5	CAN_GND	Ground
	6	CAN_L	CAN low signal
	9	CAN_H	CAN high signal

Connector pin assignment

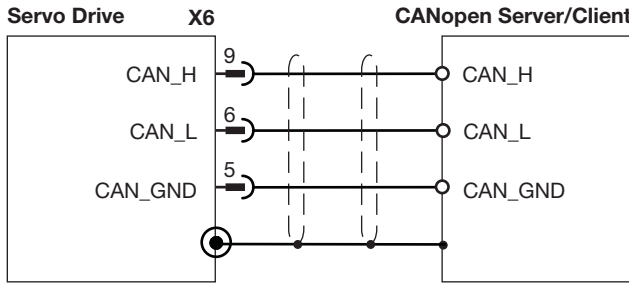
Port	CANopen
	<p>Shielded cable</p> <p>The interface is on the same connector as the RS232 interface.</p> <p>The RS232 and CANopen interface use the same operating earth (GND).</p>

Connection

The CANopen specification CiA DS-301 V4.0 requires the cable at both the start and end of the bus to be terminated with a resistor (120 Ohm, 5% metal film, 1/4 Watt).

The terminating resistor is usually integrated within the connector and can be activated there.

The cable runs for reliable communication decrease as the transmission rate is increased. The following values can be used as a guide, but they should not be regarded as limit values:

Cable data:

- ▶ Characteristic impedance 100 - 120 Ω
- ▶ Operating capacitance max. 60 nF/km
- ▶ Cable resistance (loop) 159.8 Ω/km

Transmission rate [kBit/s]	Max. cable runs [m]
1000	10
500	70
250	115

Cable runs in relation to transmission rate

Longer cable runs can be achieved with lower cable capacitance (max. 30 nF/km) and lower conductor resistance (loop, 115 Ω/km).

Characteristic impedance 150 ± 5 Ω => terminating resistor 150 ± 5 Ω.

For EMC reasons, the D-Sub connector housing must meet the following requirements:

- ▶ Metal or metal coated
- ▶ Cable shield connection on the housing, connected over a wide area

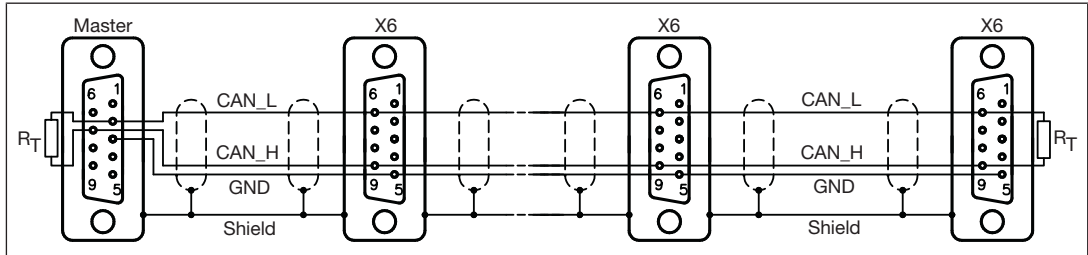

CANopen bus cable



INFORMATION

The fieldbus junction box PMCprotego D.CAN-Adapter is available as an accessory to divide the CANopen interface of the PMCprotego D into two parallel CANopen interfaces.

6.7.6.3

Ethernet-based interface

Communication is via Ether CAT.

IN Port

Socket X7A	Pin	Designation	Description
	1	TD+ (Transmit+)	Send data
	2	TD- (Transmit-)	Send data inverted
	3	RD+ (Receive+)	Receive data
	4	n. c.	--
	5	n. c.	--
	6	RD- (Receive-)	Receive data inverted
	7	n. c.	--
	8	n. c.	--
n. c.: Not connected			

OUT Port

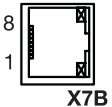
Socket X7B	Pin	Designation	Description
	1	RD+ (Receive+)	Receive data
	2	RD- (Receive-)	Receive data inverted
	3	TD+ (Transmit+)	Send data
	4	n. c.	--
	5	n. c.	--
	6	TD- (Transmit-)	Send data inverted
	7	n. c.	--
	8	n. c.	--
n. c.: Not connected			

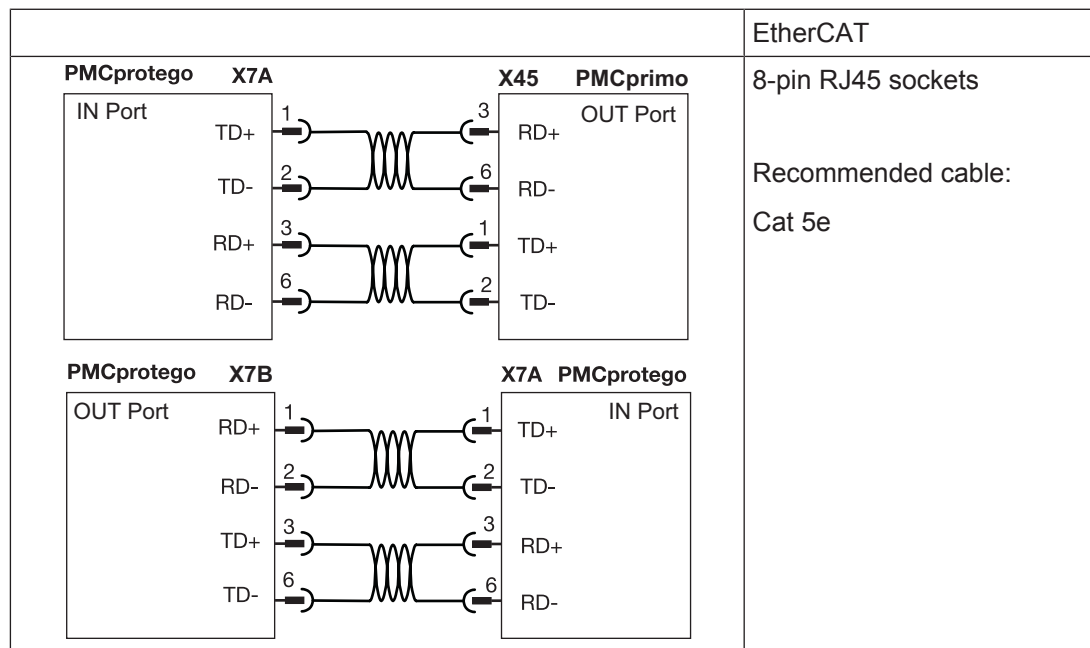

6.8 Expansion cards

6.8.1 Expansion card PMCprotego S1, PMCprotego S2

The wiring for the safety cards is described in detail in the operating manuals for the PMCprotego S1 and PMCprotego S2.



6.8.2 Expansion card I/O-14/08

Information on the connection can be found in chapter [HIPERFACE DSL, one-cable connection](#) [ 129].

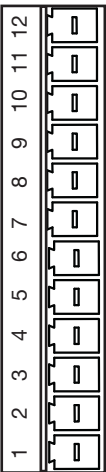
The assignment of the inputs and outputs in the tables below is the default setting (“Connector pin assignment” table, under “Designation”). It can be changed at any time in the commissioning software (see chapter entitled “Function Description” for details of the expansion card).

Connector X11A	Pin	Designation	Description
	1	A0	Digital input
	2	A1	Digital input
	3	A2	Digital input
	4	A3	Digital input
	5	A4	Digital input
	6	A5	Digital input
	7	A6	Digital input
	8	A7	Digital input
	9	Reference	Digital input
	10	S_fehl_clear	Digital input
	11	FStart_Folge	Digital input
	12	FStart_Tipp x	Digital input

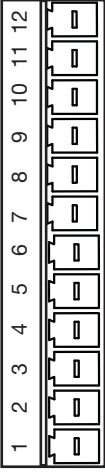
Connector pin assignment

Connector X11B	Pin	Designation	Description
	1	FRestart	Digital input
	2	FStart_I/O	Digital input
	3	InPosition	Digital output
	4	Folge-InPos / PosReg 0	Digital output
	5	S_fehl	Digital output
	6	PosReg1	Digital output
	7	PosReg2	Digital output
	8	PosReg3	Digital output
	9	PosReg4	Digital output
	10	PosReg5	Digital output
	11	24 VDC	Supply voltage 24 VDC
	12	I/O-GND	Reference earth
<hr/>			
Connector X4A/X4B	Pin	Designation	Description
	2	XGND	Reference earth

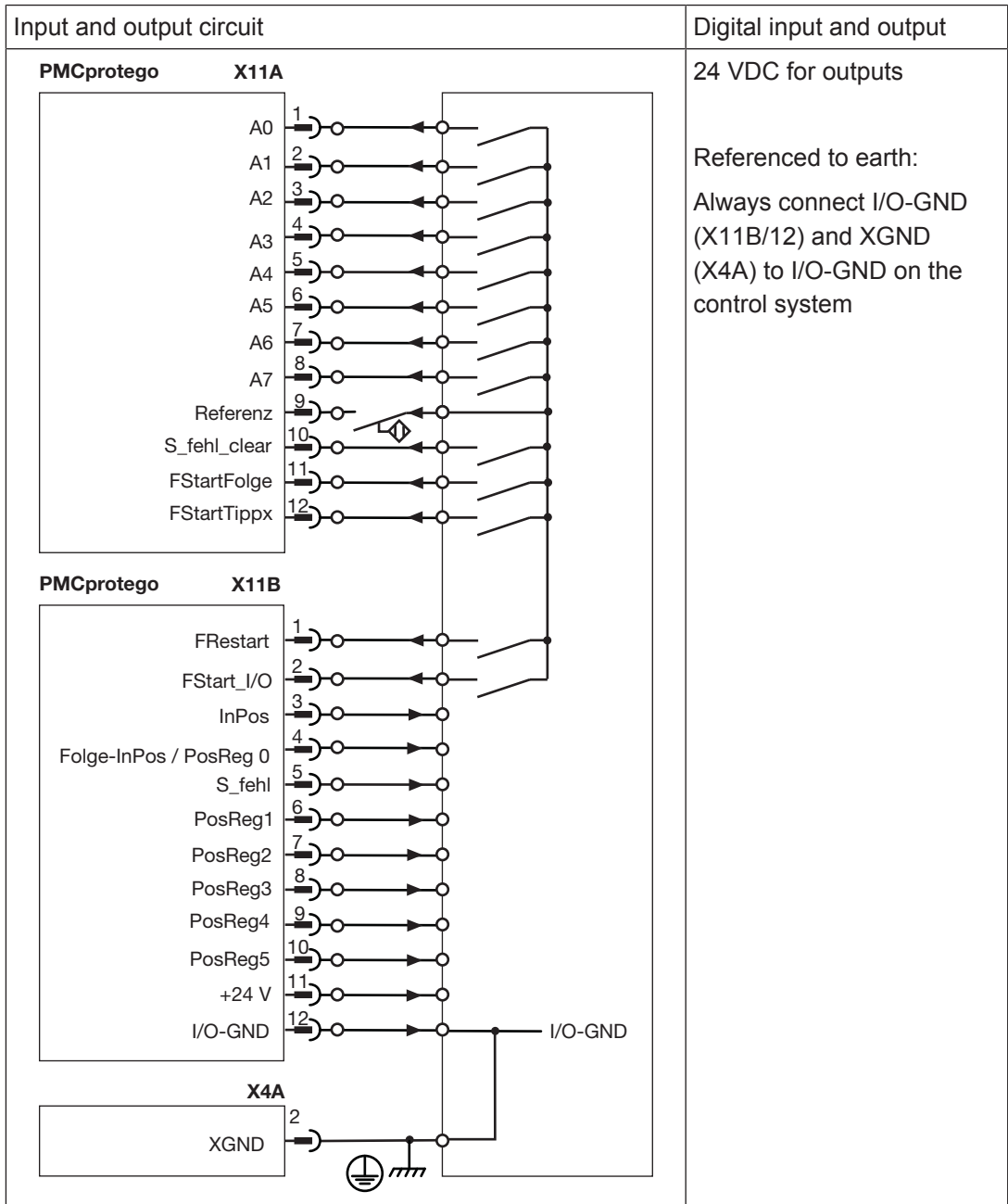

Connection

6.8.3 Expansion card PosI/O, expansion card PosI/O-AIO

Please note:

If you wish to use the encoder emulation function you will need the expansion card PosI/O or PosI/O-AIO. The expansion card is located in slot 2 or 3.



INFORMATION

A maximum of one expansion card PosI/O or PosI/O-AIO may be used in a PMCprotego D.

Information on the connection can be found in chapter [HIPERFACE DSL, one-cable connection](#) [129].

6.8.3.1 Electronic gearing Master-Slave mode

Connector X5	Pin	Designation	Description
	1	GND	Ground
	2	n. c.	--
	3	n. c.	--
	4	A-	Channel A inverted
	5	A+	Channel A
	6	B+	Channel B
	7	B-	Channel B inverted
	8	n. c.	--
	9	n. c.	--
n. c.: Not connected			

Connector pin assignment

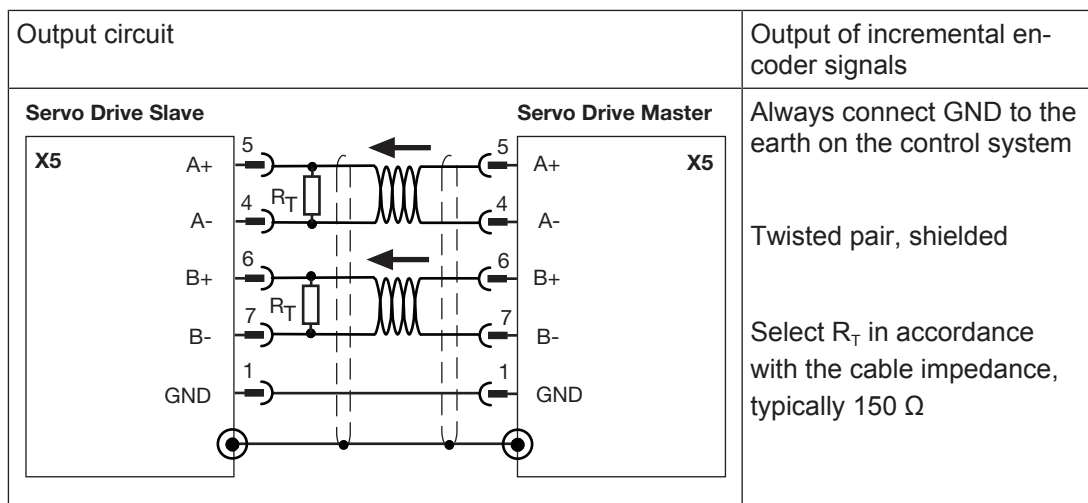

Connection

Connection to a stepper motor control system with 5 V signal

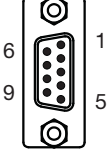
Connector X5	Pin	Designation	Description
	1	GND	Ground
	2	n. c.	--
	3	n. c.	--
	4	P-	Pulse inverted
	5	P+	Pulse
	6	D+	Direction
	7	D-	Direction inverted
	8	n. c.	--
	9	n. c.	--
n. c.: Not connected			

Connector pin assignment

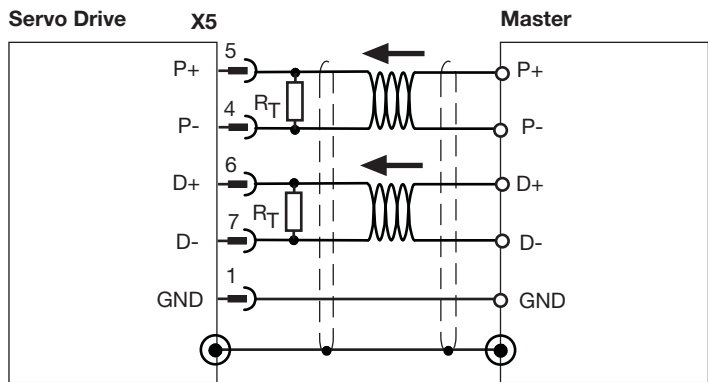
Output circuit	Output of incremental encoder signals
	<p>Always connect GND to the earth on the control system</p> <p>Twisted pair, shielded</p> <p>Select R_T in accordance with the cable impedance, typically 150 Ω</p>

Connection

6.8.3.2 Encoder emulation
Output of incremental encoder signals

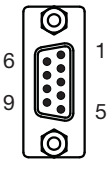
Connector X5	Pin	Designation	Description
	1	GND	Ground
	2	NI	Zero pulse
	3	NI\	Zero impulse inverted
	4	A\	Channel A inverted
	5	A	Channel A
	6	e	Channel B
	7	B\	Channel B inverted
	8	n. c.	--
	9	n. c.	--
	n. c.: Not connected		

Connector pin assignment

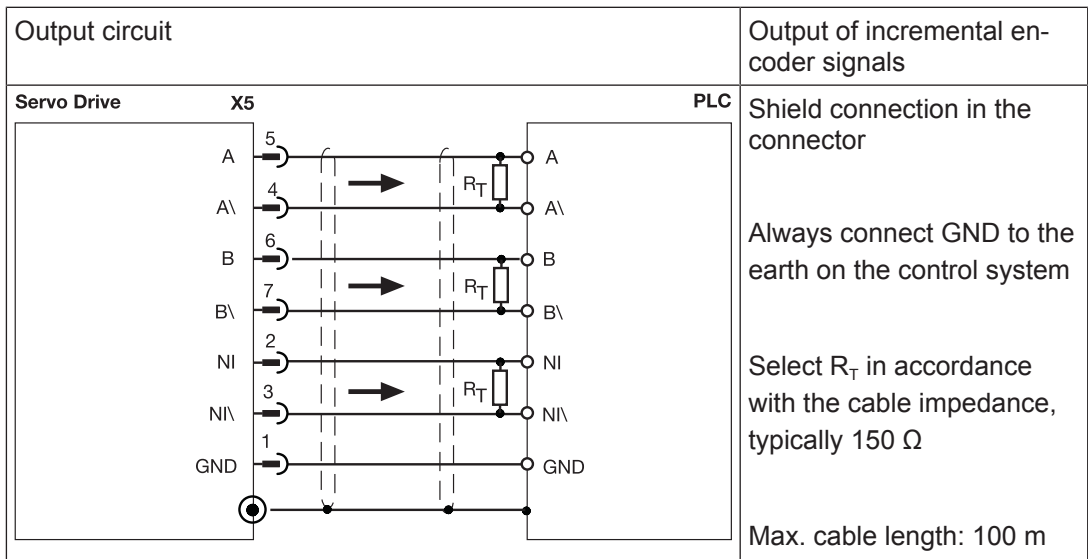

Connection

Output of SSI signals

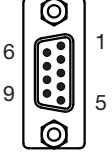
Connector X5	Pin	Designation	Description
	1	GND	Ground
	2	n. c.	--
	3	n. c.	--
	4	CLOCK	Pulse signal
	5	CLOCK\	Pulse signal inverted
	6	DATA	Channel B
	7	DATA\	Channel B inverted
	8	n. c.	--
	9	n. c.	--
n. c.: Not connected			

Connector pin assignment

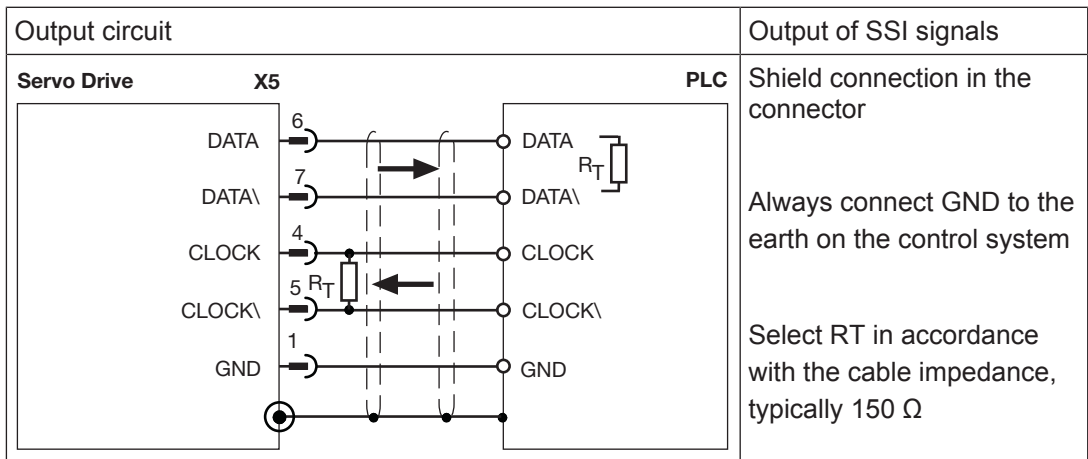

Connection

6.8.3.3 Analogue inputs and outputs

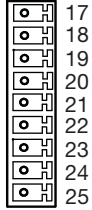
Connector X3C	Pin	Designation	Description
	17	ANALOG-OUT1	Analogue output 1
	18	AGND	Reference earth for analogue output 1
	19	ANALOG-OUT2	Analogue output 2
	20	AGND	Reference earth for analogue output 2
	21	ANALOG-IN3-	Analogue input 3-
	22	ANALOG-IN3+	Analogue input 3+
	23	AGND	Reference earth for analogue inputs
	24	ANALOG-IN4-	Analogue input 4-
	24	ANALOG-IN4+	Analogue input 4+

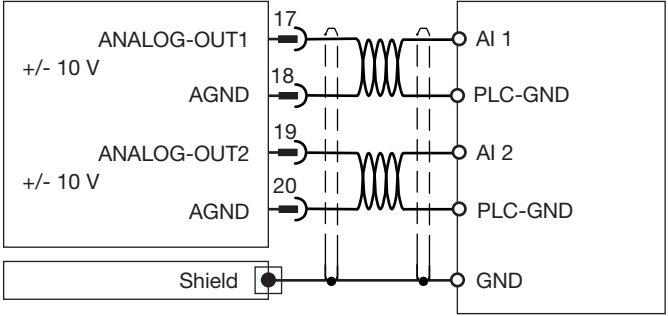
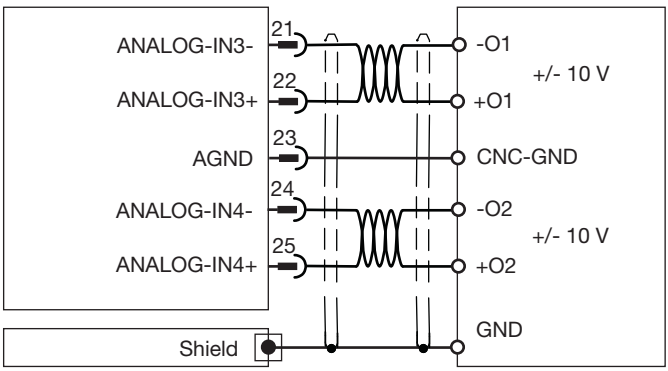
Output circuit	Analogue output
	<ul style="list-style-type: none"> - Signal range $-10 \dots +10 \text{ V}$ - Referenced to earth: Always connect AGND (X3B/13) to PLC-GND on the control system - Twisted pair, shielded - Shield connection on the front plate
Input circuit	Analogue input
	<ul style="list-style-type: none"> - Signal range $-10 \dots +10 \text{ V}$ - Referenced to earth: Always connect AGND (X3B/13) to CNC-GND on the control system - Twisted pair, shielded - Shield connection on the front plate

Connection

6.8.3.4 Incremental encoder ROD (AquadB) 5 V

Switch on the encoder's supply voltage on X1: Set ENCVON to 1

If the cable length is > 50 m, please speak to our Customer Support.

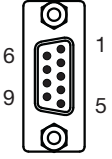
Connector X5	Pin	Designation	Description
	1	GND	Ground
	2	NI+	Zero pulse +
	3	NI-	Zero pulse -
	4	A-	Track A-
	5	A+	Track A+
	6	B+	Track B+
	7	B-	Track B-
	8	n. c.	--
	9	n. c.	--
	n. c.: Not connected		

Connector pin assignment

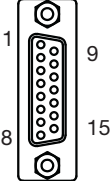
Connector X1	Pin	Designation	Description
	1	n. c.	--
	2	0 V	Supply voltage 0 V
	3	n. c.	--
	4	Up	Supply voltage 5 V
	5	n. c.	--
	6	n. c.	--
	7	ϑ	Thermal switch (+)
	8	n. c.	--
	9	n. c.	--
	10	Sense 0 V	Supply voltage feedback 0 V
	11	n. c.	--
	12	Sense Up.	Supply voltage feedback 5 V
	13	n. c.	--
	14	ϑ	Thermal switch (-)
	15	n. c.	--
n. c.: Not connected			

Connector pin assignment

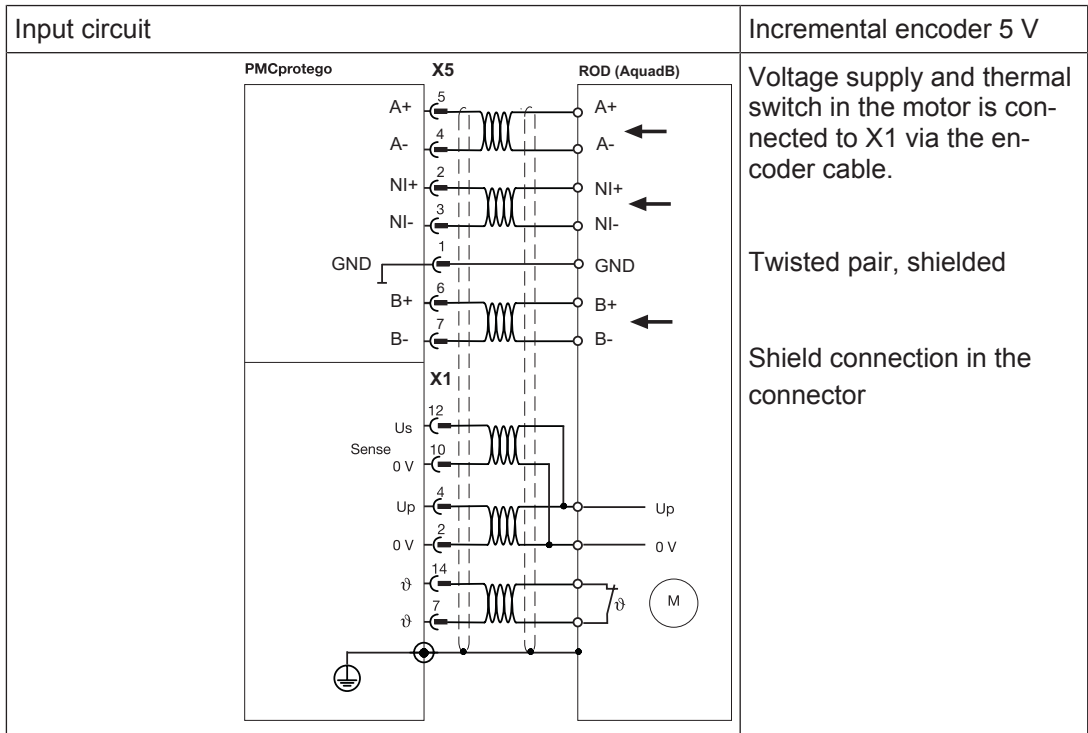

Connection

Incremental encoder ROD (AquadB) 5 V, with Hall

If the cable length is > 25 m, please speak to our Customer Support.

Connector X5	Pin	Designation	Description
	1	GND	Ground
	2	NI+	Zero pulse +
	3	NI-	Zero pulse -
	4	A-	Track A-
	5	A+	Track A+
	6	B+	Track B+
	7	B-	Track B-
	8	n. c.	--
	9	n. c.	--
n. c.: Not connected			

Connector pin assignment

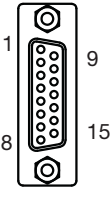
Connector X1	Pin	Designation	Description
	1	n. c.	--
	2	0 V	Supply voltage 0 V
	3	n. c.	--
	4	Up	Supply voltage 5 V
	5	n. c.	--
	6	Hall-U	Hall-U
	7	ϑ	Thermal switch (+)
	8	Hall-V	Hall-V
	9	n. c.	--
	10	Sense 0 V	Supply voltage feedback 0 V
	11	n. c.	--
	12	Sense Up.	Supply voltage feedback 5 V
	13	n. c.	--
	14	ϑ	Thermal switch (-)
	15	Hall-W	Hall-W
n. c.: Not connected			

Connector pin assignment

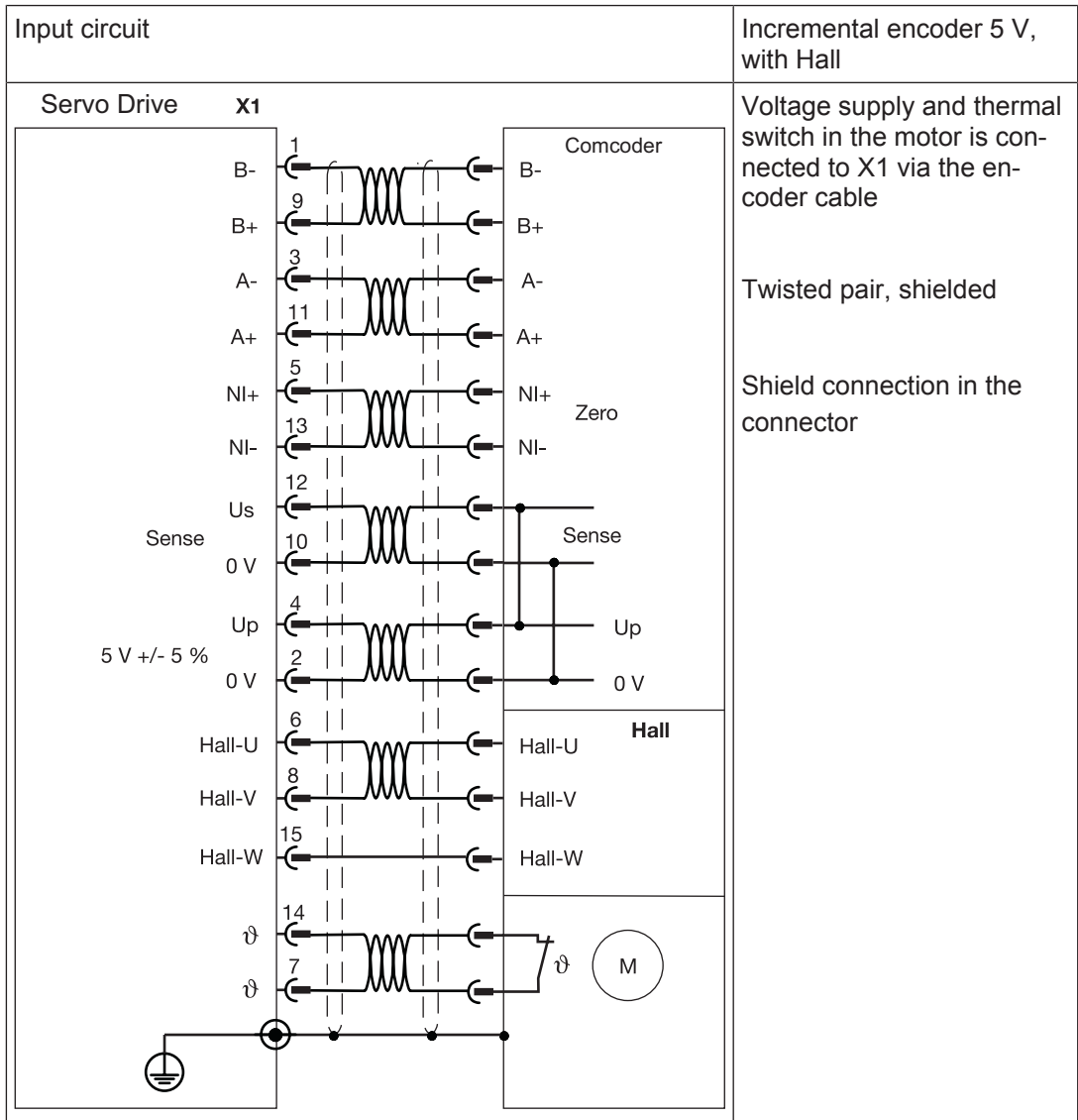

Connection

6.8.3.5 Absolute encoder with SSI interface

Switch on the encoder's supply voltage on X1: Set ENCVON to 1

If the cable length is > 50 m, please speak to our Customer Support.

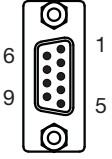
Connector X5	Pin	Designation	Description
	1	GND	Ground
	2	n. c.	--
	3	n. c.	--
	4	CLOCK\	Test pulse output inverted
	5	CLOCK	Test pulse output
	6	DATA	Data
	7	DATA\	Data inverted
	8	n. c.	--
	9	n. c.	--
	n. c.: Not connected		

Connector pin assignment

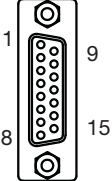
Connector X1	Pin	Designation	Description
	1	n. c.	--
	2	0 V	Supply voltage 0 V
	3	n. c.	--
	4	Up	Supply voltage 5 V
	5	n. c.	--
	6	n. c.	--
	7	ϑ	Thermal switch (+)
	8	n. c.	--
	9	n. c.	--
	10	Sense 0 V	Supply voltage feedback 0 V
	11	n. c.	--
	12	Sense Up.	Supply voltage feedback 5 V
	13	n. c.	--
	14	ϑ	Thermal switch (-)
	15	n. c.	--
n. c.: Not connected			

Connector pin assignment

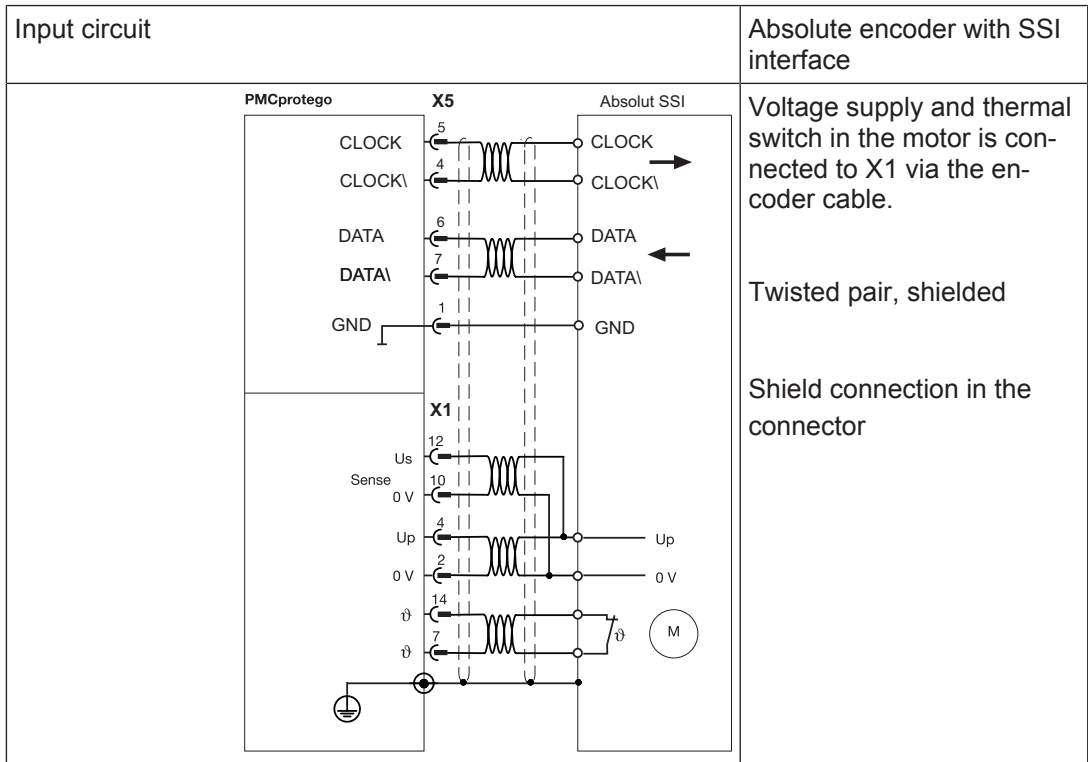

Connection

6.8.3.6 SinCos encoder with SSI interface

If the cable length is > 50 m, please speak to our Customer Support.

Connector X5	Pin	Designation	Description
	1	GND	Ground
	2	n. c.	--
	3	n. c.	--
	4	CLOCK\	Test pulse output inverted
	5	CLOCK	Test pulse output
	6	DATA	Data
	7	DATA\	Data inverted
	8	n. c.	--
	9	n. c.	--
n. c.: Not connected			

Connector pin assignment

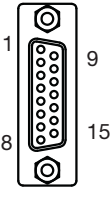
Connector X1	Pin	Designation	Description
	1	B-	Track B-
	2	0 V	Supply voltage 0 V
	3	A-	Track A-
	4	Up	Supply voltage 5 V
	5	n. c.	--
	6	n. c.	--
	7	ϑ	Thermal switch (+)
	8	n. c.	--
	9	B+	Track B+
	10	Sense 0 V	Supply voltage feedback 0 V
	11	A+	Track A+
	12	Sense Up.	Supply voltage feedback 5 V
	13	n. c.	--
	14	ϑ	Thermal switch (-)
	15	n. c.	--
n. c.: Not connected			

Connector pin assignment

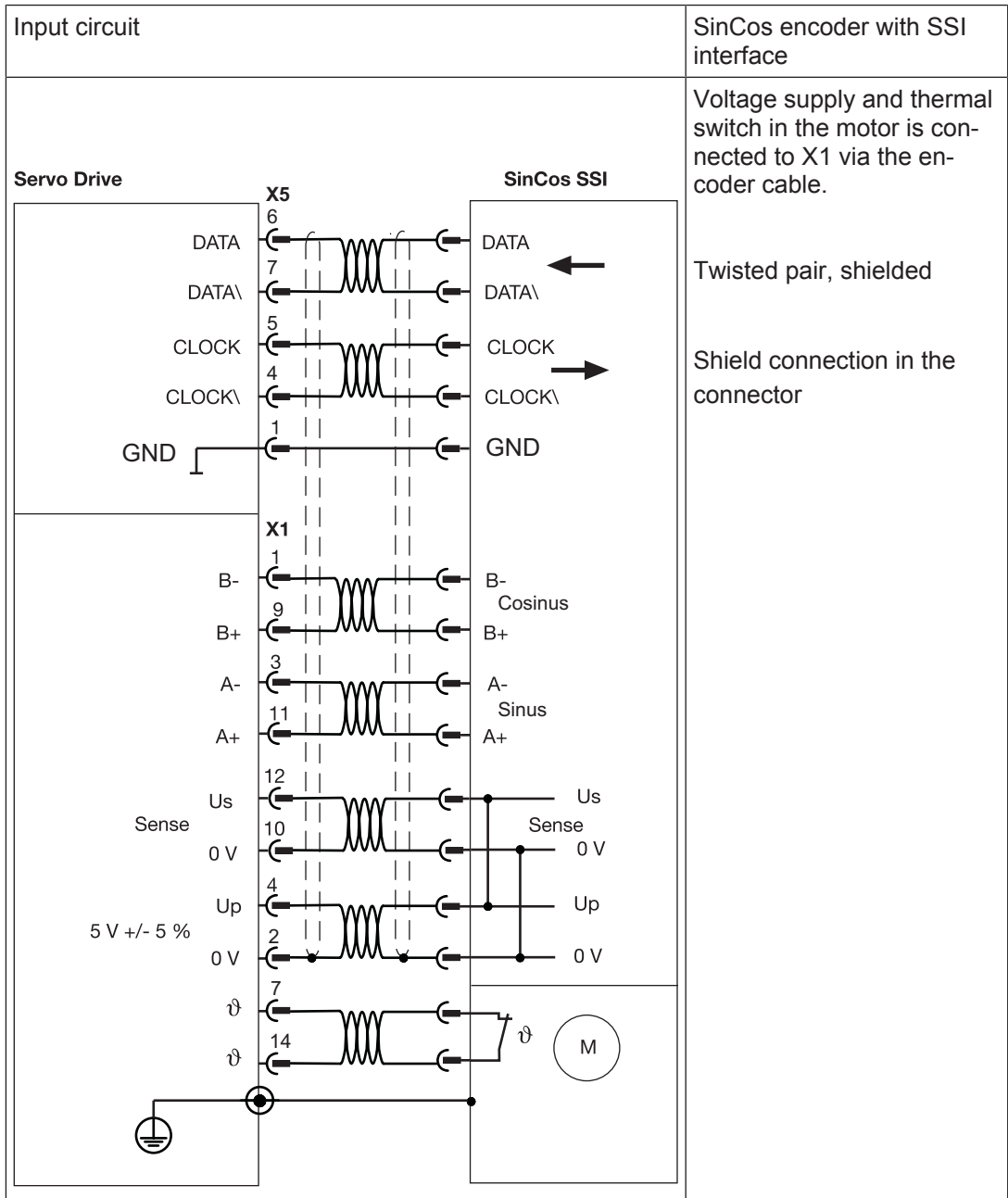

Connection

6.8.4 PROFIBUS DP interface expansion card

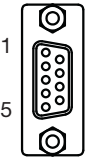
Connector X12A/ X12B	Pin	Designation	Description
	1	n. c.	--
	2	n. c.	--
	3	RxD/TxD-P	B-line
	4	n. c.	--
	5	GND	Ground
	6	VP	Supply voltage +5 V DC
	7	n. c.	--
	8	RxD/TxD-N	A-line
n. c.: Not connected			

Connector pin assignment

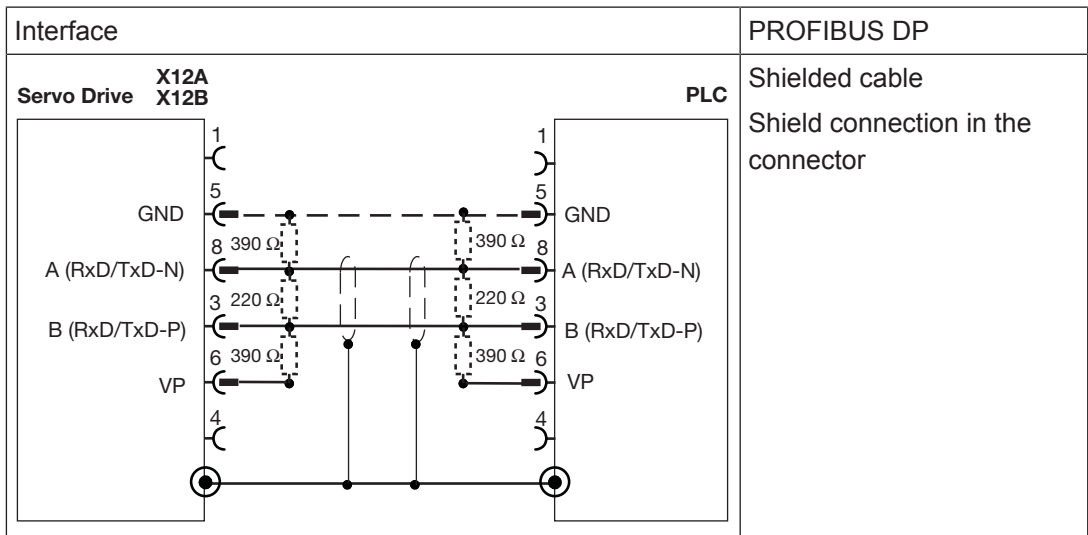

Connection



INFORMATION

Cable selection, cable routing, shielding, bus connectors, bus termination and runtimes are all described in the “PROFIBUS-DP/FMS Installation Guidelines” published by the PROFIBUS User Group PNO.

6.8.5 PROFINET interface expansion card

**INFORMATION**

For information on the PROFINET expansion card, please refer to the operating manual "PROFINET for PMCTendo DD5 and PMCprotego D".

7 Commissioning

7.1 Safety guidelines

This chapter describes the procedure for commissioning the servo amplifier for the first time, by way of example. Please note that in this case the freely rotating motor is not yet connected to the prime mover. The servo amplifier is tested using a Pilz motor.



INFORMATION

The processes described here will help you understand the principle procedure during commissioning. A detailed commissioning manual is available on our website at www.pilz.com.



DANGER!

If the servo amplifier has been **stored for longer than 1 year**, the intermediate circuit capacitors will need to be reformed. To do this you will need to unplug all the electrical connections. Supply single-phase 208 - 240V mains voltage to terminals L1 and L2 of the servo amplifier for approx. 30 minutes. This will reform the capacitors.

Please note the following safety guidelines during commissioning:

- ▶ When commissioning, you must ensure that the control systems do not present a risk to persons, plant or machinery. Appropriate protection and precautionary measures must be put in place.
- ▶ To avoid personal injury and material damage, only qualified, trained personnel should work on the devices. Qualified technical staff are those who are familiar with the transport, installation, commissioning, maintenance and operation of the device. They will be familiar with the relevant standards and regulations.
- ▶ Prior to commissioning the machine manufacturer must produce a hazard analysis for the machine and take appropriate measures to ensure that unexpected movements do not cause injury to people or damage to equipment.
- ▶ Only specialist staff with extensive knowledge of drive technology and control engineering should be permitted to program a running drive online.
- ▶ Data stored on data media is not protected from unintended changes by third parties. Data must be checked for accuracy before it is downloaded to the control system.
- ▶ Prior to installation and commissioning, information in this operating manual, and in particular the safety guidelines, must be carefully read and considered (see Chapter entitled "Safety"). Personal injury and material damage may result if devices are handled incorrectly.
- ▶ It is essential to comply with the technical details and specifications (type label and documentation).
- ▶ Life-threatening voltages up to 900 V are present. Check that all live connections are safely protected against contact.

- ▶ The heat sink and front plate temperature on the amplifier may reach 80 °C during operation. Check (measure) the temperature of the heat sink. Wait until the heat sink has cooled to 40 °C before touching it.
- ▶ Never unplug the electrical connections on the servo amplifier while voltage is applied. Residual charges in the capacitors may still carry hazardous voltages up to 8 min. after the mains voltage has been switched off (5 min. for 1.5 to 12 A types, 8 min. for 24 A types).

7.2 Commissioning the servo amplifier

Initial commissioning is a quick test of the servo amplifier. Proceed as follows:

1. Gather the project data
2. Wire components
3. Preparing for commissioning
4. Connect 24 VDC supply voltage
5. Establish communication PMCprotego <-> PC
6. Set parameters for the servo amplifier
7. Perform the first test run

1. Record project data

You will need the following information about the drive components:

- ▶ Mains voltage (network configuration, voltage value)
- ▶ Motor type (motor data, if the motor is not in the motor database, see online help)

2. Wire components

It is essential to note the following safety guidelines:



DANGER!

Risk of electrocution!

Never wire the electrical connections on the servo amplifier while voltage is applied.

Switch off the mains voltages and 24 V supply!

Make sure that the control cabinet is made safe, e.g. through an access lock or warning signs. Do not switch on the voltages until the system is commissioned!



CAUTION!

Risk of overvoltage

Overvoltage can destroy the device and lead to minor injuries.

Select the correct mains voltage and the correct device type.

**INFORMATION**

Recommendation: Note the sequence when switching on and switching off

Please note the correct order when switching on and switching off the servo amplifier. Further information is provided in Chapter [Normal mode](#) [ 84].

Configuration Example**Components**

- ▶ PMCprotego D
- ▶ Motor PMCtendo SZxx with standard encoder
- ▶ Mains contactor K1 (optional)
- ▶ 24 VDC power supply for control element
- ▶ Motor and encoder cable
- ▶ PC with installed commissioning software tool PASmotion. The current version is available on our website www.pilz.com.

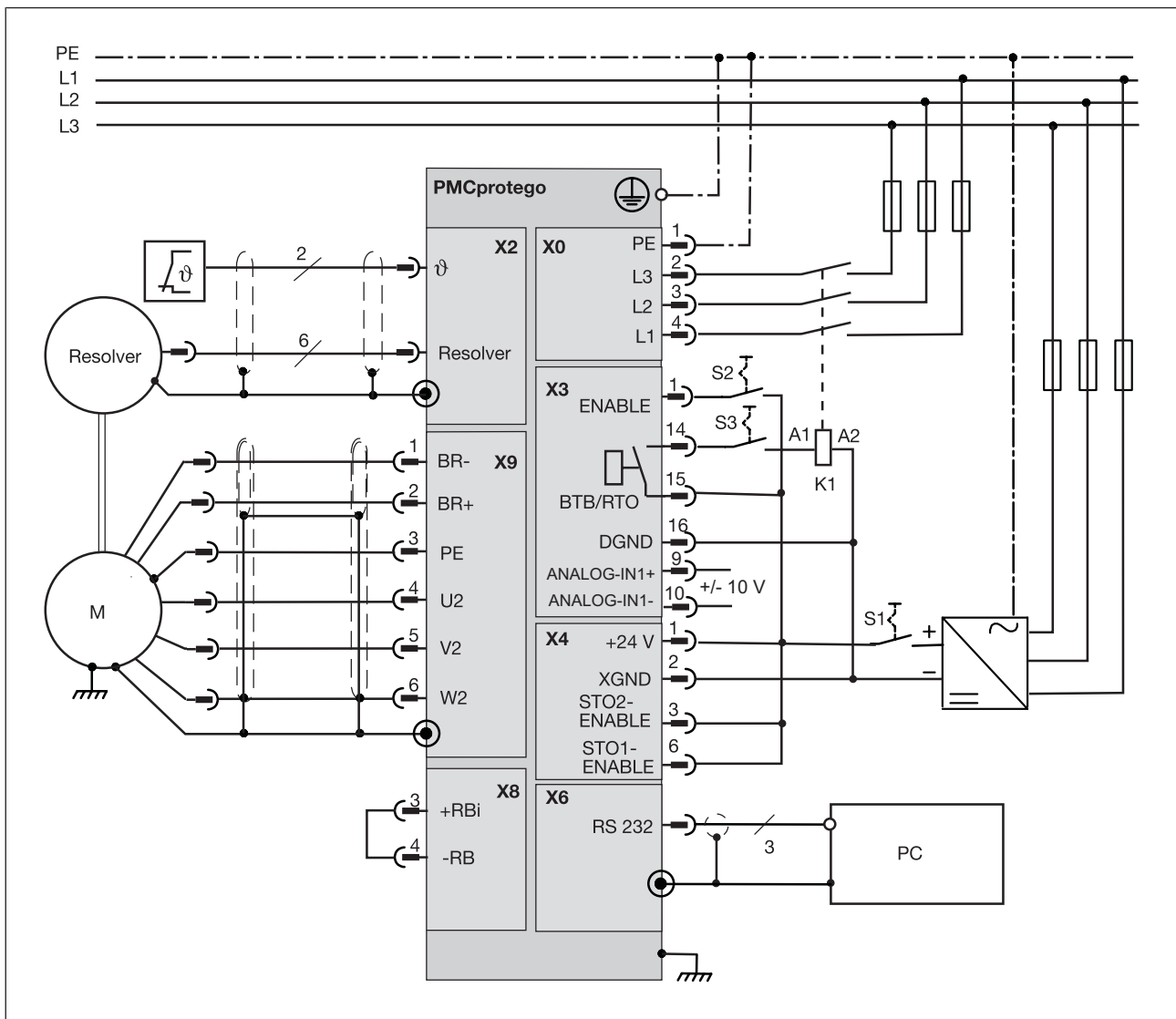

Fig.: Configuration example for commissioning

- ▶ S1: Switches on 24 VDC supply voltage
- ▶ S2: Enables the servo amplifier (hardware enable)
- ▶ S3: Switches on mains contactor, provides mains voltage to servo amplifier
- ▶ K1: Mains contactor (optional) (power is removed)
- ▶ A1: Mains contactor 24 V +
- ▶ A2: Mains contactor 24 V -

Wire components

- ▶ 24 VDC supply voltage ("+" to X4A/1 via S1 switch and "-" to X4/3)
- ▶ Enable hardware: Connect 24 VDC to terminal X3/1 via S2 switch
- ▶ Mains contactor K1
 - Connect A1 terminal to X3/14 via S3 switch
 - Connect A2 terminal to XGND on the supply voltage
- ▶ "Internal ballast resistor" mode: Link terminals X8/3 and X8/4
- ▶ "STO-ENABLE deactivated" mode: Link terminals X4A/1 und X4B/6

- ▶ Voltage for relay contact for operational readiness BTB/RTO: Link terminals X4/6 and X3/15
- ▶ Wire the main contacts of the mains contactor: Connect to mains voltage and the terminals at X0
- ▶ Wire analogue input ANALOG-IN1+/ANALOG-IN1-, X3,/9, 10
- ▶ Connect servo motor to X9 terminals
- ▶ Connect resolver to X2 sockets

3. Preparing for commissioning

Prepare the servo amplifier for commissioning:

- ▶ The mains voltage and supply voltage are switched off.
- ▶ A personal computer with the commissioning software installed is connected.
- ▶ An enable device in accordance with EN 292-1 is connected.
- ▶ The ENABLE input on the servo amplifier has a "0" signal. The servo amplifier is not enabled.

4. Connect 24 VDC supply voltage

1. Switch on 24 V power supply for the servo amplifier's control element (X4).
2. Press S1 switch "24 V on"

Procedure once supply voltage is applied:

- ▶ LED display: X.XX (firmware version)
- ▶ Relay contact for operational readiness BTB: open
- ▶ After approx. 5 seconds:
 - LED display: YY. (current strength, flashing dot for CPU O.K.)
 - Relay contact BTB: closed

5. Establish communication PMCprotego <--> PC



INFORMATION

Details descriptions of the software tools used below are available on the Tools-CD.

- ▶ Start the commissioning software PASmotion.

Configure project

1. Select **Project --> New --> Project...**
The **Create Motion Project** window is opened.
2. Enter a name for the project under **Project Name**.
3. Click on **Next**.
The **Connection Settings** window is opened.

Establish communication between the PC and servo amplifier

1. Activate **Connect and Add Discovered Devices**.
2. Click on **Serial**.
3. Select **Baud Rate: 38400**.
4. Click on **Finish**.

A search is made for the connected servo amplifier. If a connection could be established, the servo amplifier is displayed below the project name in the project directory.

6. Set parameters for the servo amplifier**Set the basic parameter settings**

Please note the following prerequisites:

- ▶ The servo amplifier must not be enabled (ENABLE = 0).
- ▶ The mains voltage must be switched off.

1. Double-click on the relevant servo amplifier in the **Project Manager**.

The window containing the **Device Information** is opened in the Drive Configurator.

Information is provided on the servo amplifier (type, serial number, firmware, ambient temperature).

2. Click on **Setup** to start the setup wizard.

The **Basic Configuration Servo Amplifier** window is opened.

You will receive a warning. This refers to the safety precautions that you need to take because the parameters you enter can be applied on the device immediately.

3. Activate **Reset All Servo Amplifier Parameters to Default Values Before Setup**.
4. Click on **Next**.

The **Basic Setup** window is opened.

5. Select **Entry 1: Analogue Speed** under **Operating Mode**.
6. Select the applicable **Mains Voltage**: 230 V, 400 V or 480 V.
7. Click on **Next**.

The **Motor Parameter-Origin** window is opened.

Select motor database

1. Select the **Motor Database** option.
2. Click on **Next**.

The **Motor Database** window is opened.

Select motor from motor database

1. Enter the motor's type code.

You'll find the type code on the motor's type plate. Make your entries using buttons (1) or (2).

Example: PMCTendo SZ.32/1/X/X/K/H/30

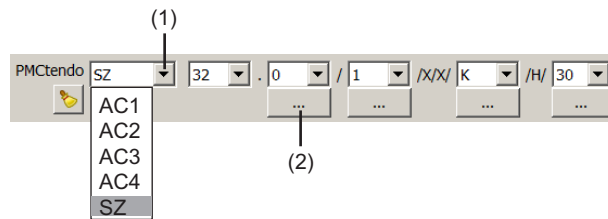

2. Click on **Next**.

A window containing safety information is opened. Read the safety information carefully.

3. Activate **Continue and Use Motor Configuration**.

4. Click on **Next**.

A window appears, with the information that you have selected new motor settings.

5. Click on **Finish**.

The motor settings will be applied if there is a connection to the servo amplifier.

Save configuration and perform hardware reset

The device configuration has been modified. As a result, the changed configuration must be saved to the EEPROM in the servo amplifier. A hardware reset must then be performed.



1. Click on the **SAVE** button (SAVE) in the service bar.

The device configuration will be saved in the EEPROM in the servo amplifier.



2. Click on the **RESET** button (RESET) in the service bar.

A hardware reset of the servo amplifier is performed.

Select encoder type (FBTYPE)

1. In parameter navigation, select **Feedback**.
2. You must select the right encoder.

Selecting the wrong encoder can lead to the destruction of the connected encoder (caused by the wrong supply voltage).

7. Perform the first test run



CAUTION!

Risk of overvoltage

Overvoltage can destroy the device and lead to minor injuries.

Select the correct mains voltage and the correct device type.

1. Select **Analogue I/O** in the Parameter Navigator.

The **Analogue I/O** window is opened

2. If necessary, change the parameters:

For example, you could select **0: Analogue In1=Speed/Current Setpoint Value** in the **Analogue Input Function** list. This way you activate the analogue input ANALOG-IN1 on X3 with +10 ... -10 VDC.

3. Click on the  button (ENABLE) in the service bar to issue the software enable for the servo amplifier.
4. Enable the axes:
 - Switch on the mains voltage: Close the S3 switch “Mains on”
 - Close the S2 switch “HW-Enable”.
5. The motor turns when a voltage of +10 ... - 10 V is present at the input ANALOG-IN1+/ANALOG-IN1-.

7.3 Download firmware from SD card to servo amplifier

New firmware can also be downloaded to the servo amplifier from an SD card inserted within the servo amplifier, without a connection to a PC.

Prerequisite:



- ▶ The SD card must be formatted with a FAT32 file system. An appropriate SD card is available as an accessory (see Order reference for accessories).
- ▶ The SD card must contain the following files:
 - default.bin or default.s19: Firmware for the servo amplifier
 - default.par: Parameter file for the servo amplifier





INFORMATION

Only plug or unplug the SD card when the supply voltage to the servo amplifier is switched off!

Procedure:

1. **Switch off the 24 V supply to the servo amplifier.**
2. **Insert the SD card into the card slot in the servo amplifier.**
3. **Keep both operator keys   on the servo amplifier pressed down.**
4. **Switch on the 24 V supply to the servo amplifier.**
5. **Release the keys when "---" appears on the display.**

The card cannot be accessed when "CCC" is displayed.
6. **Press both operator keys   again and then release.**
 - The firmware update for the servo amplifier is started.
 - The file default.bin or default.s19 is loaded.
 - Display: Counts from 0 to 100, stops at 100 and then counts from 100 to 0.
 - The servo amplifier is restarted. The parameter file default.par is loaded.



7.4 LEDs and keys

The servo amplifier has a 3-digit LED display for status, error and warning messages.

The two keys can be used to navigate the menus and also to enter numerical values for setting parameters.

7.4.1 Key functions

The keys have the following functions:

Key	Description
	<p>Press once: move up one menu item, increase number by one</p> <p>Press twice in quick succession: increase number by ten</p>
	<p>Press once: move down one menu item, decrease number by one</p> <p>Press twice in quick succession: Decrease the number by ten</p>
	<p>Hold down right-hand button and then press left-hand button: enter numbers, confirm entry</p>

The diagram below illustrates the function of the keys and LEDs.

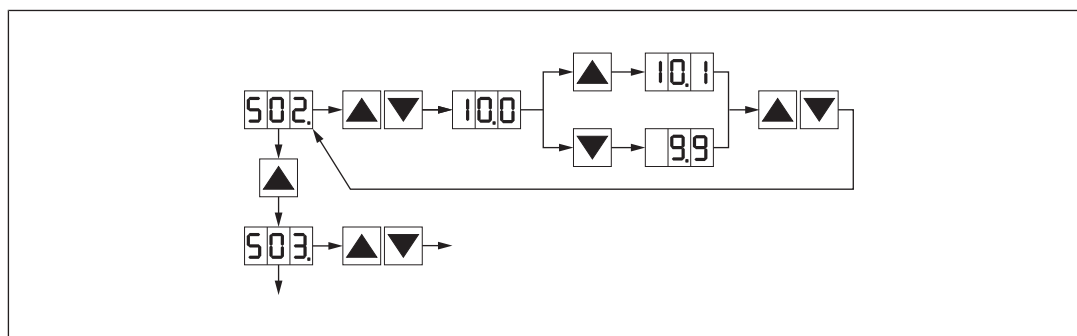

Fig.: Key functions

7.4.2 Status indicator

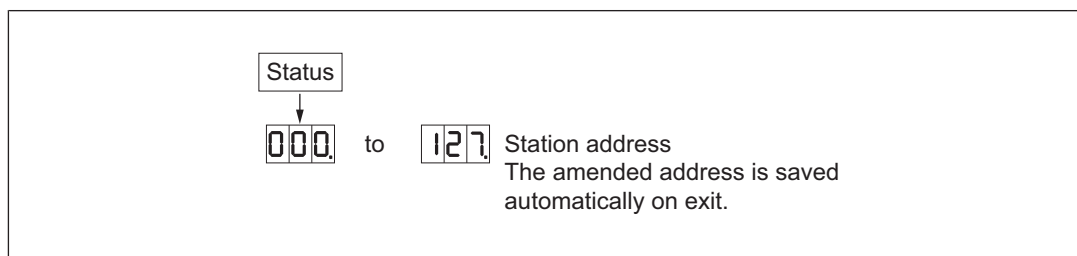

Fig.: Status indicator

7.4.3 Standard menu

Once the servo amplifier is switched on you will have access to the status, error and warning messages via the standard menu.

The diagram below shows how the display is structured.

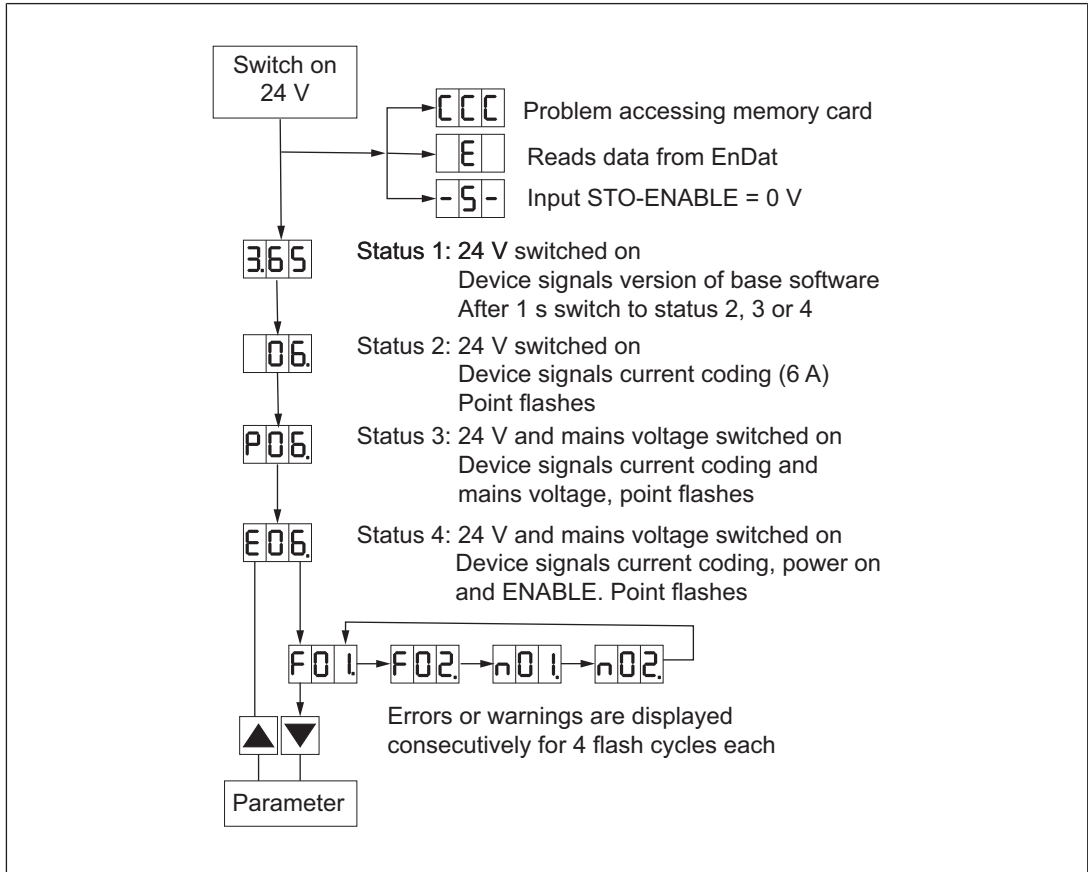

Fig.: Standard menu display

7.4.4 Advanced menu

In the advanced menu you can also change numerical values.

- ▶ Keep the right-hand button pressed down as you switch on the 24 V supply voltage

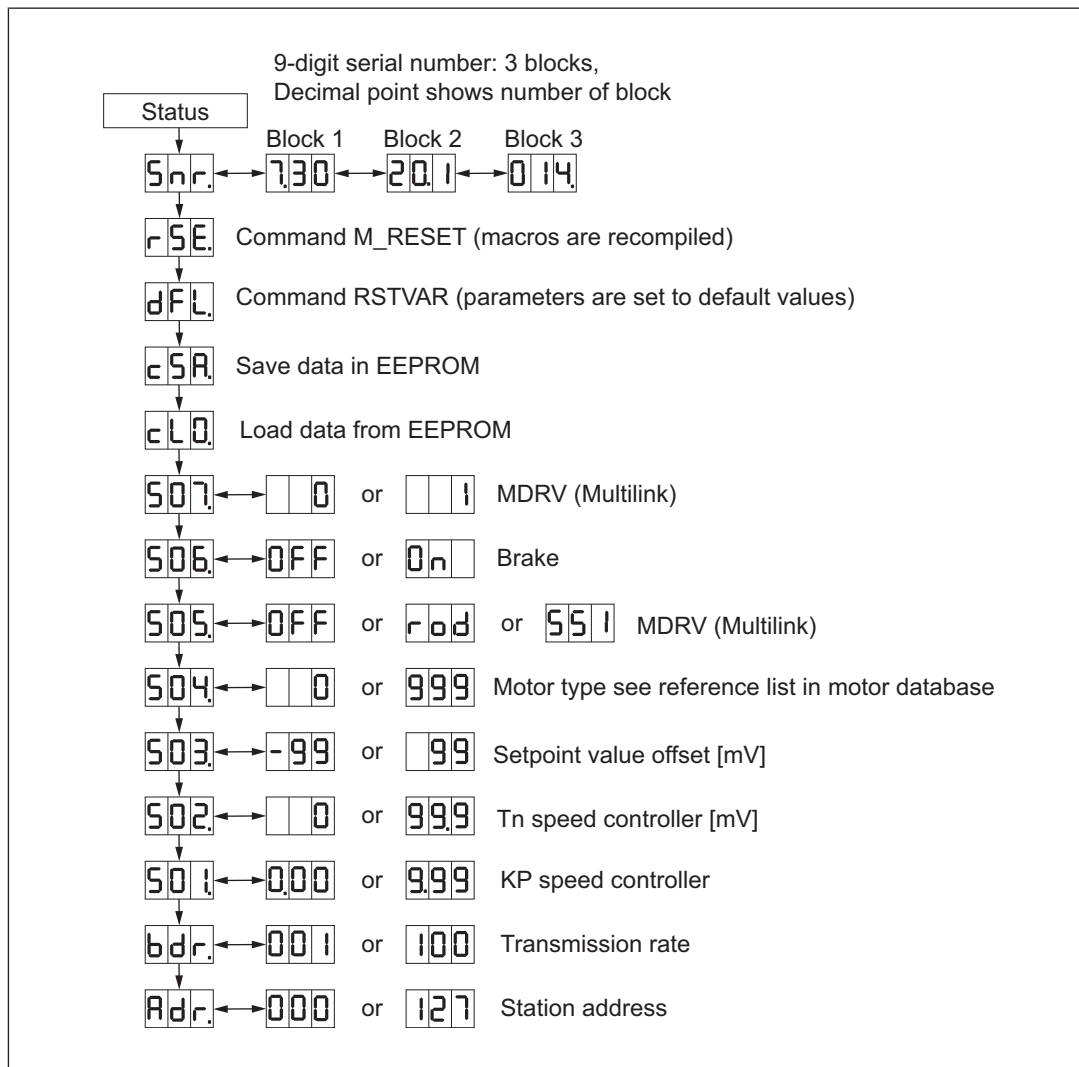

Fig.: Advanced menu

7.5 Messages/errors

7.5.1 Status messages

Status messages on the LED display indicate the operating status of the servo amplifier.

No.	Error message	Description
E/S/A/P	Status messages	Status message, no error
...	Status message	Amplifier updating the start configuration
-	Status message	Status message, no error, programming mode
- S -	STO-ENABLE	STO-ENABLE input = 0 V (if the drive is shut down)
CCC	SD card	Problem when accessing the SD card

7.5.2 Error messages

Errors are shown on the LED display with an error number. The reaction of the servo amplifier depends on the setting made for the parameter ACTFAULT.

Errors can be reset by

- ▶ a hardware reset on the servo amplifier.
- ▶ the parameter CLRFAULT (see parameter ERRCODE).

Further information is available in the ASCII object reference in the commissioning software.

No.	Error message	Description
F01	Heat sink temperature	Heatsink temperature too high (default: 80°C)
F02	Overvoltage	Overvoltage in the intermediate circuit. Limit value depends on the mains voltage
F03	Position error	Message from the position controller
F04	Feedback	Open circuit, short circuit, earth fault
F05	Undervoltage	Undervoltage in the intermediate circuit (default: 100 V)
F06	Motor temperature	Temperature sensor defective or motor temperature too high
F07	Internal voltage	Internal supply voltages faulty
F08	Overspeed	Motor runs away, speed higher than permitted
F09	EEPROM	Check sum error
F10	Reserved	Reserved
F11	Motor brake	Open circuit, short circuit, earth fault
F12	Motor phase	Motor phase missing (open circuit or similar)
F13	Ambient temperature	Ambient temperature too high
F14	Output stage	Fault in the power output stage
F15	I ² t max.	I ² t maximum value exceeded
F16	Mains BTB	2 or 3 infeed phases missing
F17	A/D Converter	Error in the analogue/digital conversion, often caused by very strong electromagnetic interference
F18	Brake chopper	Brake circuit defective or incorrect setting
F19	Intermediate circuit	Voltage drop in the intermediate circuit
F20	Expansion card error	Slot error, depends on the expansion card that's used, see ASCII command reference
F21	Handling error	Handling error on the expansion card
F22	Reserved	Reserved
F23	CAN Bus off	Major CAN Bus communication error
F24	Warning	Warning indicator assessed as an error
F25	Commutation error	Commutation error
F26	Limit switch	Reference run error (hardware limit switch reached)

No.	Error message	Description
F27	STO	Operational error with STO, STO-ENABLE and ENABLE inputs set simultaneously
F28	Fieldbus error	See also: ASCII command reference
F29	Fieldbus error	Communication disrupted, see ASCII command reference
F30	Emergency timeout	Timeout E-STOP
F31	Safety card error	Safety card's reaction monitoring is registering an error.
F32	System error	System software responds incorrectly

7.5.3

Warnings

Warning messages on the LED display indicate malfunctions. The inverted rectifier of the servo amplifier does **not** switch off (relay contact for operational readiness BTB stays closed). Warning messages are shown on the LED display with a number.

Some warning messages result in a controlled shutdown of the drive (braking with emergency ramp). The reaction of the servo amplifier depends on the type of warning (see parameter STATCODE). Further information is available in the ASCII object reference in the commissioning software.

No.	Error message	Description
n01	I ² t	I ² t signal threshold exceeded
n02	Brake power	Set brake power has been reached
n03	S_fehl	Set drag error window has been exceeded
n04	Reaction monitoring	Reaction monitoring (fieldbus) active
n05	Input phase	Input phase missing
n06	Software limit switch 1	Software limit switch 1 exceeded
n07	Software limit switch 2	Software limit switch 2 exceeded
n08	Motion_task_error	An invalid motion task has been started
n09	No reference point	No reference point was set when the motion task was started
n10	PSTOP	PSTOP limit switch operated
n11	NSTOP	NSTOP limit switch operated
n12	Motor default values loaded	ENDAT or HIPERFACE® only: Discrepancy between the motor numbers saved in the encoder and amplifier, motor default values have been loaded.
n13	Expansion card	Problem with the 24 V supply for the I/O expansion card
n14	SinCos feedback	SinCos commutation (wake & shake) incomplete, will be cleared if amplifier is enabled and wake & shake is executed
n15	Table Error	Fault as per speed/current table INXMODE 35

No.	Error message	Description
n16	Summary warning	Summary warning for n17 to n31
n17	Fieldbus Sync	CAN Sync is not logged in
n18	Multi-turn overflow	Maximum number of rotations exceeded
n19	Ramp restricted on motion block	Value range exceeded for motion block data
n20	Invalid motion block	Invalid motion block
n21	Warning through PLC program	Refer to PLC program
n22	Motor temperature exceeded	The warning gives the user options for how to respond before the "motor temperature" error causes a controller shutdown.
n23	Sine/cosine encoder	Warning threshold reached
n24	Digital inputs	Illogical configuration
n25-n31	Reserved	Reserved
n32	Firmware beta version	Firmware version has not been released

7.6 Safety checks

The machine manufacturer must check and verify the functionality of the employed safety functions.

- ▶ The safety function may only be checked by qualified personnel.

The safety function must be checked

- ▶ After initial commissioning
- ▶ After changing the configuration of the safety functions
- ▶ After exchanging the safety card or servo amplifier

A full check comprises

- ▶ Proper execution of the employed safety functions
- ▶ Inspection of the parameters

The result of the check on each safety function must be documented in a test report. This test report must be signed.



INFORMATION

If any of the parameters for the safety functions have been changed, the check must be repeated and this must be recorded in the test report.

Regular checks

Check the safety functions at regular intervals. The aim of these regular checks is to uncover any changes to the plant/machine, safety functions and ambient conditions.

You must comply with the requirements of the applicable national regulations.

The intervals you select will depend on the application, the overall system and the associated risk analysis. The test interval should not exceed one year.

Brake test

Depending on the application, the regular checks may include a test of the internal (motor brake) and external brake.



INFORMATION

For details of the function of the safe brake test, please refer to the section entitled "Safe brake test - SBT" in the operating manual for the relevant safety card.

7.7 Expansion cards

7.7.1 PROFIBUS DP interface expansion card



INFORMATION

For information on the PROFIBUS DP expansion card, please refer to the operating manual "PROFIBUS DP for PMCtendo DD5 and PMCprotego D".

7.7.2 PROFINET interface expansion card



INFORMATION

For information on the PROFINET expansion card, please refer to the operating manual "PROFINET for PMCtendo DD5 and PMCprotego D".

8 Technical details PMCprotego D.01/230 V

General	
Approvals	CE, EAC (Eurasian), TÜV
Electrical data	
Supply voltage	
Voltage	110 - 230 V
Voltage	1 x 110...3 x 230 V
Kind	AC
Kind	AC
Voltage tolerance	-10 %/+10 %
Frequency range AC	50 - 60 Hz
Supply voltage for	Supply
Voltage	24 V
Kind	DC
Tolerance	
With brake	+15 %
Without brake	+15 %
Max. current consumption	
With brake	3 A
Without brake	1 A
Current range, brake	0,15 - 2 A
Power element	
Power consumption at S1 operation	1 kVA
Max. switch-on frequency	30/h
Continuous output current at 1 x 110 VAC	1,5 A
Continuous output current at 1 x 230 VAC	1,5 A
Continuous output current at 3 x 110 VAC	2,5 A
Continuous output current at 3 x 230 VAC	2,5 A
Peak output current for 2 s	4,5 A
Peak output current for 5 s	3 A
Tolerance	-3 %/+3 %
Min. winding inductance of the motor	
at 3 x 230 V AC	8 mH
Voltage rise with open terminals	
at 3 x 230 V AC	3,3 kV/μs
Clock frequency of inverted rectifier	
In normal mode	8 kHz
With current reduced to 50 %	16 kHz
Form factor of continuous output current at min. winding inductance	1,01
Rated intermediate circuit voltage	135 - 450 V
Max. rated intermediate circuit voltage	450 V DC

Power element	
Power dissipation at max. mains voltage	
Without brake	30 W
With inverted rectifier switched off	20 W
Brake chopper power element	
Switch-on threshold	
at 230 V	400 V
Max. overvoltage, intermediate circuit	
at 230 V	455 V
Pulse brake power	
at 230 V	4 kW
Internal brake resistor RBi	33 Ohm
Continuous output RBi	50 W
External brake resistor Rbe	33 Ohm
Continuous output RBe	0,3 kW
STO-ENABLE	
Number	2
Input voltage	20 - 30 V
Input current at signal level "1"	33 - 40 mA
Reaction time STO1-ENABLE	2 ms
Reaction time STO2-ENABLE	1 ms
Resolver input	
Number	1
Connection type	9-pin D-Sub female connector
SinCos encoder input, incremental encoder	
Number	1
Connection type	15-pin D-Sub female connector
Analogue inputs	
Number of analogue inputs	2
Type of analogue inputs	Voltage
Input area	-10 ... 10 V
Resolution	16 Bit
Max. common mode voltage	-10 - 10 V
Input resistance	150 kOhm
Scan rate	16 kHz
Inputs	
Number	4 - 6
Scan rate DIGITAL-IN-1 and 2	500 kHz
Scan rate DIGITAL-IN 3 and 4	4 kHz
Signal level at "0"	-3 - +5 V DC
Signal level at "1"	15 - 30 V DC
Input current at signal level "0"	1 mA
Input current at signal level "1"	2 - 15 mA
Input voltage in accordance with EN 61131-2 Type 1	24 V DC

Inputs	
Potential isolation between input and internal module bus voltage	yes
Semiconductor outputs (standard)	
Number	2
Switching capability	
Current	0,1 A
Relay outputs	
Operational readiness function	
Number	1
Max. voltage AC	42 V
Max. voltage DC	30 V
Max. current	500 mA
CANopen interface	
Number	1
Connection type	9-pin D-Sub male connector
Ethernet interface	
Connection type	RJ45
Serial interface	
Number of RS232 interfaces	1
Communication interfaces	
RS232 and CANopen, on the same connector	
Connection type	9-pin D-Sub male connector
Environmental data	
Ambient temperature	
In accordance with the standard	DIN EN 60721-3-3
Temperature range	0 - 40 °C
Temperature range with power derating	40 - 55 °C
Power derating	2,5 %/K
Storage temperature	
In accordance with the standard	DIN EN 60721-3-1
Temperature range	-25 - 55 °C
Max. change	20 K/h
Storage temperature class	1K4
Climatic suitability	
In accordance with the standard	DIN EN 60721-3-3
Humidity	85 % r.h.
Relative humidity class	1K3
Condensation during operation	Not permitted
Max. operating height above sea level	1000 m
Max. operating height with power derating	1000 - 2500 m above sea level
Power derating	1,5 %/100 m
EMC	EN 61800-3

Environmental data	
Vibration	
In accordance with the standard	EN 60721-3-3
Class	3M1
Cooling	Fans installed
Noise emission	43 dB (A)
Airgap creepage	
Pollution degree	2
Protection type	
In accordance with the standard	EN 60529
Housing	IP20
Terminals	IP20
Mounting area (e.g. control cabinet)	IP54
Mechanical data	
Mounting position	vertical
Material	
Housing	Galvanised steel
Dimensions	
Height	345 mm
Height incl. connector	379 mm
Width	70 mm
Depth	243 mm
Depth incl. connector (accessories)	285 mm
Weight	4.400 g

Where standards are undated, the 2013-08 latest editions shall apply.

9 Technical details PMCprotego D.01/480V

General	
Approvals	CE, EAC (Eurasian), TÜV, UL Listed
Electrical data	
Supply voltage	
Voltage	208 - 480 V
Voltage	3 x 208...3 x 480 V
Kind	AC
Kind	AC
Voltage tolerance	-10 %/+10 %
Frequency range AC	50 - 60 Hz
Supply voltage for	Supply
Voltage	24 V
Kind	DC
Tolerance	
With brake	+15 %
Without brake	+15 %
Max. current consumption	
With brake	3 A
Without brake	1 A
Current range, brake	0,15 - 2 A
Power element	
Power consumption at S1 operation	1,1 kVA
Max. switch-on frequency	30/h
Continuous output current at 3 x 208 VAC	2,5 A
Continuous output current at 3 x 230 VAC	2 A
Continuous output current at 3 x 400 VAC	1,5 A
Continuous output current at 3 x 480 VAC	1,5 A
Peak output current for 2 s	4,5 A
Peak output current for 5 s	3 A
Tolerance	-3 %/+3 %
Min. winding inductance of the motor	
at 3 x 208 V AC	7,7 mH
at 3 x 230 V AC	8,5 mH
at 3 x 400 V AC	14,8 mH
at 3 x 480 V AC	17,8 mH
Voltage rise with open terminals	
at 3 x 208 V AC	3 kV/μs
at 3 x 230 V AC	3,3 kV/μs
at 3 x 400 V AC	5,7 kV/μs
at 3 x 480 V AC	6,9 kV/μs

Power element	
Clock frequency of inverted rectifier	
In normal mode	8 kHz
With current reduced to 50 %	16 kHz
Form factor of continuous output current at min. winding inductance	1,01
Rated intermediate circuit voltage	260 - 900 V
Max. rated intermediate circuit voltage	900 V DC
Power dissipation at max. mains voltage	
Without brake	40 W
With inverted rectifier switched off	20 W
Brake chopper power element	
Switch-on threshold	
at 230 V	400 V
at 400 V	720 V
at 480 V	840 V
Max. overvoltage, intermediate circuit	
at 230 V	455 V
at 400 V	800 V
at 480 V	900 V
Pulse brake power	
at 230 V	4 kW
at 400 V	15 kW
at 480 V	21 kW
Internal brake resistor RBi	33 Ohm
Continuous output RBi	50 W
External brake resistor Rbe	33 Ohm
Continuous output RBe	0,3 kW
STO-ENABLE	
Number	2
Input voltage	20 - 30 V
Input current at signal level "1"	33 - 40 mA
Reaction time STO1-ENABLE	2 ms
Reaction time STO2-ENABLE	1 ms
Resolver input	
Number	1
Connection type	9-pin D-Sub female connector
SinCos encoder input, incremental encoder	
Number	1
Connection type	15-pin D-Sub female connector
Analogue inputs	
Number of analogue inputs	2
Type of analogue inputs	Voltage
Input area	-10 ... 10 V
Resolution	16 Bit

Analogue inputs	
Max. common mode voltage	-10 - 10 V
Input resistance	150 kOhm
Scan rate	16 kHz
Inputs	
Number	4 - 6
Scan rate DIGITAL-IN-1 and 2	500 kHz
Scan rate DIGITAL-IN 3 and 4	4 kHz
Signal level at "0"	-3 - +5 V DC
Signal level at "1"	15 - 30 V DC
Input current at signal level "0"	1 mA
Input current at signal level "1"	2 - 15 mA
Input voltage in accordance with EN 61131-2 Type 1	24 V DC
Potential isolation between input and internal module bus voltage	yes
Semiconductor outputs (standard)	
Number	2
Switching capability	
Current	0,1 A
Galvanic isolation	yes
Relay outputs	
Operational readiness function	
Number	1
Max. voltage AC	42 V
Max. voltage DC	30 V
Max. current	500 mA
CANopen interface	
Number	1
Connection type	9-pin D-Sub male connector
Ethernet interface	
Connection type	RJ45
Communication interfaces	
RS232 and CANopen, on the same connector	
Connection type	9-pin D-Sub male connector
Environmental data	
Ambient temperature	
In accordance with the standard	DIN EN 60721-3-3
Temperature range	0 - 40 °C
Temperature range with power derating	40 - 55 °C
Power derating	2,5 %/K
Storage temperature	
In accordance with the standard	DIN EN 60721-3-1
Temperature range	-25 - 55 °C
Max. change	20 K/h
Storage temperature class	1K4

Environmental data	
Climatic suitability	
In accordance with the standard	DIN EN 60721-3-3
Humidity	85 % r.h.
Relative humidity class	1K3
Condensation during operation	Not permitted
EMC	EN 61800-3
Vibration	
In accordance with the standard	EN 60721-3-3
Class	3M1
Cooling	Fans installed
Noise emission	43 dB (A)
Max. operating height above sea level	1000 m
Max. operating height with power derating	1000 - 2500 m above sea level
Power derating	1,5 %/100 m
Airgap creepage	
Pollution degree	2
Protection type	
In accordance with the standard	EN 60529
Mounting area (e.g. control cabinet)	IP54
Housing	IP20
Terminals	IP20
Mechanical data	
Mounting position	vertical
Material	
Housing	Galvanised steel
Dimensions	
Height	345 mm
Height incl. connector	379 mm
Width	70 mm
Depth	243 mm
Depth incl. connector (accessories)	285 mm
Weight	4.400 g

Where standards are undated, the 2013-08 latest editions shall apply.

10 Technical details PMCprotego D.03/230 V

General	
Approvals	CE, EAC (Eurasian), TÜV
Electrical data	
Supply voltage	
Voltage	110 - 230 V
Voltage	1 x 110...3 x 230 V
Kind	AC
Kind	AC
Voltage tolerance	-10 %/+10 %
Frequency range AC	50 - 60 Hz
Supply voltage for	Supply
Voltage	24 V
Kind	DC
Tolerance	
With brake	+15 %
Without brake	+15 %
Max. current consumption	
With brake	3 A
Without brake	1 A
Current range, brake	0,15 - 2 A
Power element	
Power consumption at S1 operation	2 kVA
Max. switch-on frequency	30/h
Continuous output current at 1 x 110 VAC	3 A
Continuous output current at 1 x 230 VAC	3 A
Continuous output current at 3 x 110 VAC	5 A
Continuous output current at 3 x 230 VAC	5 A
Peak output current for 2 s	9 A
Peak output current for 5 s	6 A
Tolerance	-3 %/+3 %
Min. winding inductance of the motor	
at 3 x 230 V AC	4 mH
Voltage rise with open terminals	
at 3 x 230 V AC	3,3 kV/μs
Clock frequency of inverted rectifier	
In normal mode	8 kHz
With current reduced to 50 %	16 kHz
Form factor of continuous output current at min. winding inductance	1,01
Rated intermediate circuit voltage	135 - 450 V
Max. rated intermediate circuit voltage	450 V DC

Power element	
Power dissipation at max. mains voltage	
Without brake	45 W
With inverted rectifier switched off	20 W
Brake chopper power element	
Switch-on threshold	
at 230 V	400 V
Max. overvoltage, intermediate circuit	
at 230 V	455 V
Pulse brake power	
at 230 V	4 kW
Internal brake resistor RBi	33 Ohm
Continuous output RBi	50 W
External brake resistor Rbe	33 Ohm
Continuous output RBe	1 kW
STO-ENABLE	
Number	2
Input voltage	20 - 30 V
Input current at signal level "1"	33 - 40 mA
Reaction time STO1-ENABLE	2 ms
Reaction time STO2-ENABLE	1 ms
Resolver input	
Number	1
Connection type	9-pin D-Sub female connector
SinCos encoder input, incremental encoder	
Number	1
Connection type	15-pin D-Sub female connector
Analogue inputs	
Number of analogue inputs	2
Type of analogue inputs	Voltage
Input area	-10 ... 10 V
Resolution	16 Bit
Max. common mode voltage	-10 - 10 V
Input resistance	150 kOhm
Scan rate	16 kHz
Inputs	
Number	4 - 6
Scan rate DIGITAL-IN-1 and 2	500 kHz
Scan rate DIGITAL-IN 3 and 4	4 kHz
Signal level at "0"	-3 - +5 V DC
Signal level at "1"	15 - 30 V DC
Input current at signal level "0"	1 mA
Input current at signal level "1"	2 - 15 mA
Input voltage in accordance with EN 61131-2 Type 1	24 V DC

Inputs	
Potential isolation between input and internal module bus voltage	yes
Semiconductor outputs (standard)	
Number	2
Switching capability	
Current	0,1 A
Relay outputs	
Operational readiness function	
Number	1
Max. voltage AC	42 V
Max. voltage DC	30 V
Max. current	500 mA
CANopen interface	
Number	1
Connection type	9-pin D-Sub male connector
Ethernet interface	
Connection type	RJ45
Serial interface	
Number of RS232 interfaces	1
Communication interfaces	
RS232 and CANopen, on the same connector	
Connection type	9-pin D-Sub male connector
Environmental data	
Ambient temperature	
In accordance with the standard	DIN EN 60721-3-3
Temperature range	0 - 40 °C
Temperature range with power derating	40 - 55 °C
Power derating	2,5 %/K
Storage temperature	
In accordance with the standard	DIN EN 60721-3-1
Temperature range	-25 - 55 °C
Max. change	20 K/h
Storage temperature class	1K4
Climatic suitability	
In accordance with the standard	DIN EN 60721-3-3
Humidity	85 % r.h.
Relative humidity class	1K3
Condensation during operation	Not permitted
Max. operating height above sea level	1000 m
Max. operating height with power derating	1000 - 2500 m above sea level
Power derating	1,5 %/100 m
EMC	EN 61800-3

Environmental data	
Vibration	
In accordance with the standard	EN 60721-3-3
Class	3M1
Cooling	Fans installed
Noise emission	43 dB (A)
Airgap creepage	
Pollution degree	2
Protection type	
In accordance with the standard	EN 60529
Mounting area (e.g. control cabinet)	IP54
Housing	IP20
Terminals	IP20
Mechanical data	
Mounting position	vertical
Material	
Housing	Galvanised steel
Dimensions	
Height	345 mm
Height incl. connector	379 mm
Width	70 mm
Depth	243 mm
Depth incl. connector (accessories)	285 mm
Weight	4.400 g
General	
Approvals	CE, EAC (Eurasian), TÜV, UL Listed
Electrical data	
Supply voltage	
Voltage	3 x 208...3 x 480 V
Kind	AC
Voltage tolerance	-10 %/+10 %
Frequency range AC	50 - 60 Hz
Supply voltage	
for	Supply
Voltage	24 V
Kind	DC
Tolerance	
With brake	+15 %
Without brake	+15 %
Max. current consumption	
With brake	3,0 A
Without brake	1,0 A
Current range, brake	0,15 - 2,00 A
Power element	
Power consumption at S1 operation	2,2 kVA

Power element	
Max. switch-on frequency	30/h
Continuous output current at 3 x 208 VAC	5,0 A
Continuous output current at 3 x 230 VAC	4,0 A
Continuous output current at 3 x 400 VAC	3,0 A
Continuous output current at 3 x 480 VAC	3,0 A
Peak output current for 2 s	9,00 A
Peak output current for 5 s	6,00 A
Tolerance	-3 %/+3 %
Min. winding inductance of the motor	
at 3 x 208 V AC	3,90 mH
at 3 x 230 V AC	4,30 mH
at 3 x 400 V AC	7,40 mH
at 3 x 480 V AC	8,90 mH
Voltage rise with open terminals	
at 3 x 208 V AC	3,0 kV/μs
at 3 x 230 V AC	3,3 kV/μs
at 3 x 400 V AC	5,7 kV/μs
at 3 x 480 V AC	6,9 kV/μs
Clock frequency of inverted rectifier	
In normal mode	8 kHz
With current reduced to 50 %	16 kHz
Form factor of continuous output current at min. winding inductance	1,01
Rated intermediate circuit voltage	290 - 675 V
Max. rated intermediate circuit voltage	900 V DC
Power dissipation at max. mains voltage	
Without brake	70 W
With inverted rectifier switched off	20 W
Brake chopper power element	
Switch-on threshold	
at 230 V	400 V
at 400 V	720 V
at 480 V	840 V
Max. overvoltage, intermediate circuit	
at 230 V	455 V
at 400 V	800 V
at 480 V	900 V
Pulse brake power	
at 230 V	4,00 kW
at 400 V	15 kW
at 480 V	21 kW
Internal brake resistor RBi	33 Ohm
Continuous output RBi	50 W
External brake resistor RBe	33 Ohm
Continuous output RBe	1,0 kW

STO-ENABLE	
Number	2
Input voltage	20 - 30 V
Input current at signal level "1"	33 - 40 mA
Reaction time STO1-ENABLE	2 ms
Reaction time STO2-ENABLE	1 ms
Resolver input	
Number	1
Connection type	9-pin D-Sub female connector
SinCos encoder input, incremental encoder	
Number	1
Connection type	15-pin D-Sub female connector
Analogue inputs	
Number of analogue inputs	2
Type of analogue inputs	Voltage
Input area	-10 ... 10 V
Resolution	16 Bit
Max. common mode voltage	-10 - 10 V
Input resistance	150,0 kOhm
Scan rate	16 kHz
Inputs	
Number	4 - 6
Scan rate DIGITAL-IN-1 and 2	500 kHz
Scan rate DIGITAL-IN 3 and 4	4 kHz
Signal level at "0"	-3 - +5 V DC
Signal level at "1"	15 - 30 V DC
Input current at signal level "0"	1 mA
Input current at signal level "1"	2 - 15 mA
Input voltage in accordance with EN 61131-2 Type 1	24 V DC
Potential isolation between input and internal module bus voltage	yes
Semiconductor outputs (standard)	
Number	2
Switching capability	
Current	0,10 A
Galvanic isolation	yes
Relay outputs	
Operational readiness function	
Number	1
Max. voltage AC	42 V
Max. voltage DC	30 V
Max. current	500 mA
Ethernet interface	
Connection type	RJ45

Communication interfaces	
RS232 and CANopen, on the same connector	
Connection type	9-pin D-Sub male connector
Environmental data	
Ambient temperature	
In accordance with the standard	DIN EN 60721-3-3
Temperature range	0 - 40 °C
Temperature range with power derating	40 - 55 °C
Power derating	2,5 %/K
Storage temperature	
In accordance with the standard	DIN EN 60721-3-1
Temperature range	-25 - 55 °C
Max. change	20 K/h
Storage temperature class	1K4
Climatic suitability	
In accordance with the standard	DIN EN 60721-3-3
Humidity	85 % r.h.
Relative humidity class	1K3
Condensation during operation	Not permitted
EMC	EN 61800-3
Vibration	
In accordance with the standard	EN 60721-3-3
Class	3M1
Cooling	Fans installed
Noise emission	43 dB (A)
Max. operating height above sea level	1000 m
Max. operating height with power derating	1000 - 2500 m above sea level
Power derating	1,5 %/100 m
Airgap creepage	
Pollution degree	2
Protection type	
In accordance with the standard	EN 60529
Mounting area (e.g. control cabinet)	IP54
Housing	IP20
Terminals	IP20
Mechanical data	
Mounting position	vertical
Material	
Housing	Galvanised steel
Dimensions	
Height	345,0 mm
Height incl. connector	379 mm
Width	70,0 mm
Depth	243,0 mm
Depth incl. connector (accessories)	285,0 mm

Mechanical data

Weight	4.400 g
--------	----------------

Where standards are undated, the 2013-08 latest editions shall apply.

11 Technical details PMCprotego D.03/480V

General	
Approvals	CE, EAC (Eurasian), TÜV, UL Listed
Electrical data	
Supply voltage	
Voltage	3 x 208...3 x 480 V
Kind	AC
Voltage tolerance	-10 %/+10 %
Frequency range AC	50 - 60 Hz
Supply voltage	
for	Supply
Voltage	24 V
Kind	DC
Tolerance	
With brake	+15 %
Without brake	+15 %
Max. current consumption	
With brake	3,0 A
Without brake	1,0 A
Current range, brake	0,15 - 2,00 A
Power element	
Power consumption at S1 operation	2,2 kVA
Max. switch-on frequency	30/h
Continuous output current at 3 x 208 VAC	5,0 A
Continuous output current at 3 x 230 VAC	4,0 A
Continuous output current at 3 x 400 VAC	3,0 A
Continuous output current at 3 x 480 VAC	3,0 A
Peak output current for 2 s	9,00 A
Peak output current for 5 s	6,00 A
Tolerance	-3 %/+3 %
Min. winding inductance of the motor	
at 3 x 208 V AC	3,90 mH
at 3 x 230 V AC	4,30 mH
at 3 x 400 V AC	7,40 mH
at 3 x 480 V AC	8,90 mH
Voltage rise with open terminals	
at 3 x 208 V AC	3,0 kV/μs
at 3 x 230 V AC	3,3 kV/μs
at 3 x 400 V AC	5,7 kV/μs
at 3 x 480 V AC	6,9 kV/μs
Clock frequency of inverted rectifier	
In normal mode	8 kHz
With current reduced to 50 %	16 kHz

Power element	
Form factor of continuous output current at min. winding inductance	1,01
Rated intermediate circuit voltage	290 - 675 V
Max. rated intermediate circuit voltage	900 V DC
Power dissipation at max. mains voltage	
Without brake	70 W
With inverted rectifier switched off	20 W
Brake chopper power element	
Switch-on threshold	
at 230 V	400 V
at 400 V	720 V
at 480 V	840 V
Max. overvoltage, intermediate circuit	
at 230 V	455 V
at 400 V	800 V
at 480 V	900 V
Pulse brake power	
at 230 V	4,00 kW
at 400 V	15 kW
at 480 V	21 kW
Internal brake resistor R _{Bi}	33 Ohm
Continuous output R _{Bi}	50 W
External brake resistor R _{Be}	33 Ohm
Continuous output R _{Be}	1,0 kW
STO-ENABLE	
Number	2
Input voltage	20 - 30 V
Input current at signal level "1"	33 - 40 mA
Reaction time STO1-ENABLE	2 ms
Reaction time STO2-ENABLE	1 ms
Resolver input	
Number	1
Connection type	9-pin D-Sub female connector
SinCos encoder input, incremental encoder	
Number	1
Connection type	15-pin D-Sub female connector
Analogue inputs	
Number of analogue inputs	2
Type of analogue inputs	Voltage
Input area	-10 ... 10 V
Resolution	16 Bit
Max. common mode voltage	-10 - 10 V
Input resistance	150,0 kOhm
Scan rate	16 kHz

Inputs	
Number	4 - 6
Scan rate DIGITAL-IN-1 and 2	500 kHz
Scan rate DIGITAL-IN 3 and 4	4 kHz
Signal level at "0"	-3 - +5 V DC
Signal level at "1"	15 - 30 V DC
Input current at signal level "0"	1 mA
Input current at signal level "1"	2 - 15 mA
Input voltage in accordance with EN 61131-2 Type 1	24 V DC
Potential isolation between input and internal module bus voltage	yes
Semiconductor outputs (standard)	
Number	2
Switching capability	
Current	0,10 A
Galvanic isolation	yes
Relay outputs	
Operational readiness function	
Number	1
Max. voltage AC	42 V
Max. voltage DC	30 V
Max. current	500 mA
Ethernet interface	
Connection type	RJ45
Communication interfaces	
RS232 and CANopen, on the same connector	
Connection type	9-pin D-Sub male connector
Environmental data	
Ambient temperature	
In accordance with the standard	DIN EN 60721-3-3
Temperature range	0 - 40 °C
Temperature range with power derating	40 - 55 °C
Power derating	2,5 %/K
Storage temperature	
In accordance with the standard	DIN EN 60721-3-1
Temperature range	-25 - 55 °C
Max. change	20 K/h
Storage temperature class	1K4
Climatic suitability	
In accordance with the standard	DIN EN 60721-3-3
Humidity	85 % r.h.
Relative humidity class	1K3
Condensation during operation	Not permitted
EMC	EN 61800-3

Environmental data	
Vibration	
In accordance with the standard	EN 60721-3-3
Class	3M1
Cooling	Fans installed
Noise emission	43 dB (A)
Max. operating height above sea level	1000 m
Max. operating height with power derating	1000 - 2500 m above sea level
Power derating	1,5 %/100 m
Airgap creepage	
Pollution degree	2
Protection type	
In accordance with the standard	EN 60529
Mounting area (e.g. control cabinet)	IP54
Housing	IP20
Terminals	IP20
Mechanical data	
Mounting position	vertical
Material	
Housing	Galvanised steel
Dimensions	
Height	345,0 mm
Height incl. connector	379 mm
Width	70,0 mm
Depth	243,0 mm
Depth incl. connector (accessories)	285,0 mm
Weight	4.400 g

Where standards are undated, the 2013-08 latest editions shall apply.

12 Technical details PMCprotego D.06/230 V

General	
Approvals	CE, EAC (Eurasian), TÜV
Electrical data	
Supply voltage	
Voltage	110 - 230 V
Voltage	1 x 110...3 x 230 V
Kind	AC
Kind	AC
Voltage tolerance	-10 %/+10 %
Frequency range AC	50 - 60 Hz
Supply voltage for	Supply
Voltage	24 V
Kind	DC
Tolerance	
With brake	+15 %
Without brake	+15 %
Max. current consumption	
With brake	3 A
Without brake	1 A
Current range, brake	0,15 - 2 A
Power element	
Power consumption at S1 operation	2,3 kVA
Max. switch-on frequency	30/h
Continuous output current at 1 x 110 VAC	6 A
Continuous output current at 1 x 230 VAC	6 A
Continuous output current at 3 x 110 VAC	6 A
Continuous output current at 3 x 230 VAC	6 A
Peak output current for 2 s	18 A
Peak output current for 5 s	12 A
Tolerance	-3 %/+3 %
Min. winding inductance of the motor	
at 3 x 230 V AC	2 mH
Voltage rise with open terminals	
at 3 x 230 V AC	3,3 kV/μs
Clock frequency of inverted rectifier	
In normal mode	8 kHz
With current reduced to 50 %	16 kHz
Form factor of continuous output current at min. winding inductance	1,01
Rated intermediate circuit voltage	135 - 450 V
Max. rated intermediate circuit voltage	450 V DC

Power element	
Power dissipation at max. mains voltage	
Without brake	60 W
With inverted rectifier switched off	20 W
Brake chopper power element	
Switch-on threshold	
at 230 V	400 V
Max. overvoltage, intermediate circuit	
at 230 V	455 V
Pulse brake power	
at 230 V	4 kW
Internal brake resistor RBi	33 Ohm
Continuous output RBi	75 W
External brake resistor Rbe	33 Ohm
Continuous output RBe	1 kW
STO-ENABLE	
Number	2
Input voltage	20 - 30 V
Input current at signal level "1"	33 - 40 mA
Reaction time STO1-ENABLE	2 ms
Reaction time STO2-ENABLE	1 ms
Resolver input	
Number	1
Connection type	9-pin D-Sub female connector
SinCos encoder input, incremental encoder	
Number	1
Connection type	15-pin D-Sub female connector
Analogue inputs	
Number of analogue inputs	2
Type of analogue inputs	Voltage
Input area	-10 ... 10 V
Resolution	16 Bit
Max. common mode voltage	-10 - 10 V
Input resistance	150 kOhm
Scan rate	16 kHz
Inputs	
Number	4 - 6
Scan rate DIGITAL-IN-1 and 2	500 kHz
Scan rate DIGITAL-IN 3 and 4	4 kHz
Signal level at "0"	-3 - +5 V DC
Signal level at "1"	15 - 30 V DC
Input current at signal level "0"	1 mA
Input current at signal level "1"	2 - 15 mA
Input voltage in accordance with EN 61131-2 Type 1	24 V DC

Inputs	
Potential isolation between input and internal module bus voltage	yes
Semiconductor outputs (standard)	
Number	2
Switching capability	
Current	0,1 A
Relay outputs	
Operational readiness function	
Number	1
Max. voltage AC	42 V
Max. voltage DC	30 V
Max. current	500 mA
CANopen interface	
Number	1
Connection type	9-pin D-Sub male connector
Ethernet interface	
Connection type	RJ45
Serial interface	
Number of RS232 interfaces	1
Communication interfaces	
RS232 and CANopen, on the same connector	
Connection type	9-pin D-Sub male connector
Environmental data	
Ambient temperature	
In accordance with the standard	DIN EN 60721-3-3
Temperature range	0 - 40 °C
Temperature range with power derating	40 - 55 °C
Power derating	2,5 %/K
Storage temperature	
In accordance with the standard	DIN EN 60721-3-1
Temperature range	-25 - 55 °C
Max. change	20 K/h
Storage temperature class	1K4
Climatic suitability	
In accordance with the standard	DIN EN 60721-3-3
Humidity	85 % r.h.
Relative humidity class	1K3
Condensation during operation	Not permitted
Max. operating height above sea level	1000 m
Max. operating height with power derating	1000 - 2500 m above sea level
Power derating	1,5 %/100 m
EMC	EN 61800-3

Environmental data	
Vibration	
In accordance with the standard	EN 60721-3-3
Class	3M1
Cooling	Fans installed
Noise emission	58 dB (A)
Airgap creepage	
Pollution degree	2
Protection type	
In accordance with the standard	EN 60529
Mounting area (e.g. control cabinet)	IP54
Housing	IP20
Terminals	IP20
Mechanical data	
Mounting position	vertical
Material	
Housing	Galvanised steel
Dimensions	
Height	345 mm
Height incl. connector	379 mm
Width	70 mm
Depth	243 mm
Depth incl. connector (accessories)	285 mm
Weight	4.400 g

Where standards are undated, the 2013-08 latest editions shall apply.

13 Technical details PMCprotego D.06/480V

General	
Approvals	CE, EAC (Eurasian), TÜV, UL Listed
Electrical data	
Supply voltage	
Voltage	208 - 480 V
Voltage	3 x 208...3 x 480 V
Kind	AC
Kind	AC
Voltage tolerance	-10 %/+10 %
Frequency range AC	50 - 60 Hz
Supply voltage for	Supply
Voltage	24 V
Kind	DC
Tolerance	
With brake	+15 %
Without brake	+15 %
Max. current consumption	
With brake	3 A
Without brake	1 A
Current range, brake	0,15 - 2 A
Power element	
Power consumption at S1 operation	4,5 kVA
Max. switch-on frequency	30/h
Continuous output current at 3 x 208 VAC	6 A
Continuous output current at 3 x 230 VAC	6 A
Continuous output current at 3 x 400 VAC	6 A
Continuous output current at 3 x 480 VAC	6 A
Peak output current for 2 s	18 A
Peak output current for 5 s	12 A
Tolerance	-3 %/+3 %
Min. winding inductance of the motor	
at 3 x 208 V AC	1,9 mH
at 3 x 230 V AC	2,1 mH
at 3 x 400 V AC	3,7 mH
at 3 x 480 V AC	4,4 mH
Voltage rise with open terminals	
at 3 x 208 V AC	3 kV/μs
at 3 x 230 V AC	3,3 kV/μs
at 3 x 400 V AC	5,7 kV/μs
at 3 x 480 V AC	6,9 kV/μs

Power element	
Clock frequency of inverted rectifier	
In normal mode	8 kHz
With current reduced to 50 %	16 kHz
Form factor of continuous output current at min. winding inductance	1,01
Rated intermediate circuit voltage	260 - 900 V
Max. rated intermediate circuit voltage	900 V DC
Power dissipation at max. mains voltage	
Without brake	100 W
With inverted rectifier switched off	20 W
Brake chopper power element	
Switch-on threshold	
at 230 V	400 V
at 400 V	720 V
at 480 V	840 V
Max. overvoltage, intermediate circuit	
at 230 V	455 V
at 400 V	800 V
at 480 V	900 V
Pulse brake power	
at 230 V	4 kW
at 400 V	15 kW
at 480 V	21 kW
Internal brake resistor RBi	33 Ohm
Continuous output RBi	75 W
External brake resistor RBe	33 Ohm
Continuous output RBe	1 kW
STO-ENABLE	
Number	2
Input voltage	20 - 30 V
Input current at signal level "1"	33 - 40 mA
Reaction time STO1-ENABLE	2 ms
Reaction time STO2-ENABLE	1 ms
Resolver input	
Number	1
Connection type	9-pin D-Sub female connector
SinCos encoder input, incremental encoder	
Number	1
Connection type	15-pin D-Sub female connector
Analogue inputs	
Number of analogue inputs	2
Type of analogue inputs	Voltage
Input area	-10 ... 10 V
Resolution	16 Bit

Analogue inputs	
Max. common mode voltage	-10 - 10 V
Input resistance	150 kOhm
Scan rate	16 kHz
Inputs	
Number	4 - 6
Scan rate DIGITAL-IN-1 and 2	500 kHz
Scan rate DIGITAL-IN 3 and 4	4 kHz
Signal level at "0"	-3 - +5 V DC
Signal level at "1"	15 - 30 V DC
Input current at signal level "0"	1 mA
Input current at signal level "1"	2 - 15 mA
Input voltage in accordance with EN 61131-2 Type 1	24 V DC
Potential isolation between input and internal module bus voltage	yes
Semiconductor outputs (standard)	
Number	2
Switching capability	
Current	0,1 A
Galvanic isolation	yes
Relay outputs	
Operational readiness function	
Number	1
Max. voltage AC	42 V
Max. voltage DC	30 V
Max. current	500 mA
CANopen interface	
Number	1
Connection type	9-pin D-Sub male connector
Ethernet interface	
Connection type	RJ45
Communication interfaces	
RS232 and CANopen, on the same connector	
Connection type	9-pin D-Sub male connector
Environmental data	
Ambient temperature	
In accordance with the standard	DIN EN 60721-3-3
Temperature range	0 - 40 °C
Temperature range with power derating	40 - 55 °C
Power derating	2,5 %/K
Storage temperature	
In accordance with the standard	DIN EN 60721-3-1
Temperature range	-25 - 55 °C
Max. change	20 K/h
Storage temperature class	1K4

Environmental data	
Climatic suitability	
In accordance with the standard	DIN EN 60721-3-3
Humidity	85 % r.h.
Relative humidity class	1K3
Condensation during operation	Not permitted
EMC	EN 61800-3
Vibration	
In accordance with the standard	EN 60721-3-3
Class	3M1
Cooling	Fans installed
Noise emission	58 dB (A)
Max. operating height above sea level	1000 m
Max. operating height with power derating	1000 - 2500 m above sea level
Power derating	1,5 %/100 m
Airgap creepage	
Pollution degree	2
Protection type	
In accordance with the standard	EN 60529
Mounting area (e.g. control cabinet)	IP54
Housing	IP20
Terminals	IP20
Mechanical data	
Mounting position	vertical
Material	
Housing	Galvanised steel
Dimensions	
Height	345 mm
Height incl. connector	379 mm
Width	70 mm
Depth	243 mm
Depth incl. connector (accessories)	285 mm
Weight	4.400 g

Where standards are undated, the 2013-08 latest editions shall apply.

14 Technical details PMCprotego D.12/230 V

General	
Approvals	CE, EAC (Eurasian), TÜV
Electrical data	
Supply voltage	
Voltage	110 - 230 V
Voltage	1 x 110...3 x 230 V
Kind	AC
Kind	AC
Voltage tolerance	-10 %/+10 %
Frequency range AC	50 - 60 Hz
Supply voltage for	Supply
Voltage	24 V
Kind	DC
Tolerance	
With brake	+15 %
Without brake	+15 %
Max. current consumption	
With brake	3 A
Without brake	1 A
Current range, brake	0,15 - 2 A
Power element	
Power consumption at S1 operation	4,5 kVA
Max. switch-on frequency	30/h
Continuous output current at 1 x 110 VAC	7 A
Continuous output current at 1 x 230 VAC	12 A
Continuous output current at 3 x 110 VAC	12 A
Continuous output current at 3 x 230 VAC	2,5 A
Peak output current for 2 s	24 A
Peak output current for 5 s	24 A
Tolerance	-3 %/+3 %
Min. winding inductance of the motor	
at 3 x 230 V AC	1,5 mH
Voltage rise with open terminals	
at 3 x 230 V AC	3,3 kV/μs
Clock frequency of inverted rectifier	
In normal mode	8 kHz
With current reduced to 50 %	16 kHz
Form factor of continuous output current at min. winding inductance	1,01
Rated intermediate circuit voltage	135 - 450 V
Max. rated intermediate circuit voltage	450 V DC

Power element	
Power dissipation at max. mains voltage	
Without brake	90 W
With inverted rectifier switched off	20 W
Brake chopper power element	
Switch-on threshold	
at 230 V	400 V
Max. overvoltage, intermediate circuit	
at 230 V	455 V
Pulse brake power	
at 230 V	4 kW
Internal brake resistor RBi	33 Ohm
Continuous output RBi	100 W
External brake resistor Rbe	33 Ohm
Continuous output RBe	1,5 kW
STO-ENABLE	
Number	2
Input voltage	20 - 30 V
Input current at signal level "1"	33 - 40 mA
Reaction time STO1-ENABLE	2 ms
Reaction time STO2-ENABLE	1 ms
Resolver input	
Number	1
Connection type	9-pin D-Sub female connector
SinCos encoder input, incremental encoder	
Number	1
Connection type	15-pin D-Sub female connector
Analogue inputs	
Number of analogue inputs	2
Type of analogue inputs	Voltage
Input area	-10 ... 10 V
Resolution	16 Bit
Max. common mode voltage	-10 - 10 V
Input resistance	150 kOhm
Scan rate	16 kHz
Inputs	
Number	4 - 6
Scan rate DIGITAL-IN-1 and 2	500 kHz
Scan rate DIGITAL-IN 3 and 4	4 kHz
Signal level at "0"	-3 - +5 V DC
Signal level at "1"	15 - 30 V DC
Input current at signal level "0"	1 mA
Input current at signal level "1"	2 - 15 mA
Input voltage in accordance with EN 61131-2 Type 1	24 V DC

Inputs	
Potential isolation between input and internal module bus voltage	yes
Semiconductor outputs (standard)	
Number	2
Switching capability	
Current	0,1 A
Relay outputs	
Operational readiness function	
Number	1
Max. voltage AC	42 V
Max. voltage DC	30 V
Max. current	500 mA
CANopen interface	
Number	1
Connection type	9-pin D-Sub male connector
Ethernet interface	
Connection type	RJ45
Serial interface	
Number of RS232 interfaces	1
Communication interfaces	
RS232 and CANopen, on the same connector	
Connection type	9-pin D-Sub male connector
Environmental data	
Ambient temperature	
In accordance with the standard	DIN EN 60721-3-3
Temperature range	0 - 40 °C
Temperature range with power derating	40 - 55 °C
Power derating	2,5 %/K
Storage temperature	
In accordance with the standard	DIN EN 60721-3-1
Temperature range	-25 - 55 °C
Max. change	20 K/h
Storage temperature class	1K4
Climatic suitability	
In accordance with the standard	DIN EN 60721-3-3
Humidity	85 % r.h.
Relative humidity class	1K3
Condensation during operation	Not permitted
Max. operating height above sea level	1000 m
Max. operating height with power derating	1000 - 2500 m above sea level
Power derating	1,5 %/100 m
EMC	EN 61800-3

Environmental data	
Vibration	
In accordance with the standard	EN 60721-3-3
Class	3M1
Cooling	
	Fans installed
Noise emission	
	65 dB (A)
Airgap creepage	
Pollution degree	2
Protection type	
In accordance with the standard	EN 60529
Mounting area (e.g. control cabinet)	IP54
Housing	IP20
Terminals	IP20
Mechanical data	
Mounting position	
	vertical
Material	
Housing	Galvanised steel
Dimensions	
Height	345 mm
Height incl. connector	379 mm
Width	70 mm
Depth	243 mm
Depth incl. connector (accessories)	285 mm
Weight	
	4.400 g

Where standards are undated, the 2013-08 latest editions shall apply.

15 Technical details PMCprotego D.12/480V

General	
Approvals	CE, EAC (Eurasian), TÜV, UL Listed
Electrical data	
Supply voltage	
Voltage	208 - 480 V
Voltage	3 x 208...3 x 480 V
Kind	AC
Kind	AC
Voltage tolerance	-10 %/+10 %
Frequency range AC	50 - 60 Hz
Supply voltage for	Supply
Voltage	24 V
Kind	DC
Tolerance	
With brake	+15 %
Without brake	+15 %
Max. current consumption	
With brake	3 A
Without brake	1 A
Current range, brake	0,15 - 2 A
Power element	
Power consumption at S1 operation	9 kVA
Max. switch-on frequency	30/h
Continuous output current at 3 x 208 VAC	12 A
Continuous output current at 3 x 230 VAC	12 A
Continuous output current at 3 x 400 VAC	12 A
Continuous output current at 3 x 480 VAC	12 A
Peak output current for 2 s	24 A
Peak output current for 5 s	24 A
Tolerance	-3 %/+3 %
Min. winding inductance of the motor	
at 3 x 208 V AC	1,2 mH
at 3 x 230 V AC	1,3 mH
at 3 x 400 V AC	2,2 mH
at 3 x 480 V AC	2,7 mH
Voltage rise with open terminals	
at 3 x 208 V AC	3 kV/μs
at 3 x 230 V AC	3,3 kV/μs
at 3 x 400 V AC	5,7 kV/μs
at 3 x 480 V AC	6,9 kV/μs

Power element	
Clock frequency of inverted rectifier	
In normal mode	8 kHz
With current reduced to 50 %	16 kHz
Form factor of continuous output current at min. winding inductance	1,01
Rated intermediate circuit voltage	260 - 900 V
Max. rated intermediate circuit voltage	900 V DC
Power dissipation at max. mains voltage	
Without brake	160 W
With inverted rectifier switched off	20 W
Brake chopper power element	
Switch-on threshold	
at 230 V	400 V
at 400 V	720 V
at 480 V	840 V
Max. overvoltage, intermediate circuit	
at 230 V	455 V
at 400 V	800 V
at 480 V	900 V
Pulse brake power	
at 230 V	4 kW
at 400 V	15 kW
at 480 V	21 kW
Internal brake resistor RBi	33 Ohm
Continuous output RBi	100 W
External brake resistor Rbe	33 Ohm
Continuous output RBe	1,5 kW
STO-ENABLE	
Number	2
Input voltage	20 - 30 V
Input current at signal level "1"	33 - 40 mA
Reaction time STO1-ENABLE	2 ms
Reaction time STO2-ENABLE	1 ms
Resolver input	
Number	1
Connection type	9-pin D-Sub female connector
SinCos encoder input, incremental encoder	
Number	1
Connection type	15-pin D-Sub female connector
Analogue inputs	
Number of analogue inputs	2
Type of analogue inputs	Voltage
Input area	-10 ... 10 V
Resolution	16 Bit

Analogue inputs	
Max. common mode voltage	-10 - 10 V
Input resistance	150 kOhm
Scan rate	16 kHz
Inputs	
Number	4 - 6
Scan rate DIGITAL-IN-1 and 2	500 kHz
Scan rate DIGITAL-IN 3 and 4	4 kHz
Signal level at "0"	-3 - +5 V DC
Signal level at "1"	15 - 30 V DC
Input current at signal level "0"	1 mA
Input current at signal level "1"	2 - 15 mA
Input voltage in accordance with EN 61131-2 Type 1	24 V DC
Potential isolation between input and internal module bus voltage	yes
Semiconductor outputs (standard)	
Number	2
Switching capability	
Current	0,1 A
Galvanic isolation	yes
Relay outputs	
Operational readiness function	
Number	1
Max. voltage AC	42 V
Max. voltage DC	30 V
Max. current	500 mA
CANopen interface	
Number	1
Connection type	9-pin D-Sub male connector
Ethernet interface	
Connection type	RJ45
Serial interface	
Number of RS232 interfaces	1
Communication interfaces	
RS232 and CANopen, on the same connector	
Connection type	9-pin D-Sub male connector
Environmental data	
Ambient temperature	
In accordance with the standard	DIN EN 60721-3-3
Temperature range	0 - 40 °C
Temperature range with power derating	40 - 55 °C
Power derating	2,5 %/K

Environmental data	
Storage temperature	
In accordance with the standard	DIN EN 60721-3-1
Temperature range	-25 - 55 °C
Max. change	20 K/h
Storage temperature class	1K4
Climatic suitability	
In accordance with the standard	DIN EN 60721-3-3
Humidity	85 % r.h.
Relative humidity class	1K3
Condensation during operation	Not permitted
EMC	EN 61800-3
Vibration	
In accordance with the standard	EN 60721-3-3
Class	3M1
Cooling	Fans installed
Noise emission	65 dB (A)
Max. operating height above sea level	1000 m
Max. operating height with power derating	1000 - 2500 m above sea level
Power derating	1,5 %/100 m
Airgap creepage	
Pollution degree	2
Protection type	
In accordance with the standard	EN 60529
Mounting area (e.g. control cabinet)	IP54
Housing	IP20
Terminals	IP20
Mechanical data	
Mounting position	vertical
Material	
Housing	Galvanised steel
Dimensions	
Height	345 mm
Height incl. connector	379 mm
Width	70 mm
Depth	243 mm
Depth incl. connector (accessories)	285 mm
Weight	4.400 g

Where standards are undated, the 2013-08 latest editions shall apply.

16 Technical details PMCprotego D.12 P/230 V

General	
Approvals	CE, EAC (Eurasian), TÜV
Electrical data	
Supply voltage	
Voltage	110 - 230 V
Voltage	1 x 110...3 x 230 V
Kind	AC
Kind	AC
Voltage tolerance	-10 %/+10 %
Frequency range AC	50 - 60 Hz
Supply voltage for	Supply
Voltage	24 V
Kind	DC
Tolerance	
With brake	+15 %
Without brake	+15 %
Max. current consumption	
With brake	3 A
Without brake	1 A
Current range, brake	0,15 - 2 A
Power element	
Power consumption at S1 operation	4,5 kVA
Max. switch-on frequency	30/h
Continuous output current at 1 x 110 VAC	7 A
Continuous output current at 1 x 230 VAC	8 A
Continuous output current at 3 x 110 VAC	12 A
Continuous output current at 3 x 230 VAC	12 A
Peak output current for 2 s	30 A
Peak output current for 5 s	24 A
Tolerance	-3 %/+3 %
Min. winding inductance of the motor	
at 3 x 230 V AC	1,2 mH
Voltage rise with open terminals	
at 3 x 230 V AC	3,3 kV/μs
Clock frequency of inverted rectifier	
In normal mode	8 kHz
With current reduced to 50 %	16 kHz
Form factor of continuous output current at min. winding inductance	1,01
Rated intermediate circuit voltage	135 - 450 V
Max. rated intermediate circuit voltage	450 V DC

Power element	
Power dissipation at max. mains voltage	
Without brake	90 W
With inverted rectifier switched off	20 W
Brake chopper power element	
Switch-on threshold	
at 230 V	400 V
Max. overvoltage, intermediate circuit	
at 230 V	455 V
Pulse brake power	
at 230 V	4 kW
Internal brake resistor RBi	33 Ohm
Continuous output RBi	100 W
External brake resistor Rbe	33 Ohm
Continuous output RBe	1,5 kW
STO-ENABLE	
Number	2
Input voltage	20 - 30 V
Input current at signal level "1"	33 - 40 mA
Reaction time STO1-ENABLE	2 ms
Reaction time STO2-ENABLE	1 ms
Resolver input	
Number	1
Connection type	9-pin D-Sub female connector
SinCos encoder input, incremental encoder	
Number	1
Connection type	15-pin D-Sub female connector
Analogue inputs	
Number of analogue inputs	2
Type of analogue inputs	Voltage
Input area	-10 ... 10 V
Resolution	16 Bit
Max. common mode voltage	-10 - 10 V
Input resistance	150 kOhm
Scan rate	16 kHz
Inputs	
Number	4 - 6
Scan rate DIGITAL-IN-1 and 2	500 kHz
Scan rate DIGITAL-IN 3 and 4	4 kHz
Signal level at "0"	-3 - +5 V DC
Signal level at "1"	15 - 30 V DC
Input current at signal level "0"	1 mA
Input current at signal level "1"	2 - 15 mA
Input voltage in accordance with EN 61131-2 Type 1	24 V DC

Inputs	
Potential isolation between input and internal module bus voltage	yes
Semiconductor outputs (standard)	
Number	2
Switching capability	
Current	0,1 A
Relay outputs	
Operational readiness function	
Number	1
Max. voltage AC	42 V
Max. voltage DC	30 V
Max. current	500 mA
CANopen interface	
Number	1
Connection type	9-pin D-Sub male connector
Ethernet interface	
Connection type	RJ45
Serial interface	
Number of RS232 interfaces	1
Communication interfaces	
RS232 and CANopen, on the same connector	
Connection type	9-pin D-Sub male connector
Environmental data	
Ambient temperature	
In accordance with the standard	DIN EN 60721-3-3
Temperature range	0 - 40 °C
Temperature range with power derating	40 - 55 °C
Power derating	2,5 %/K
Storage temperature	
In accordance with the standard	DIN EN 60721-3-1
Temperature range	-25 - 55 °C
Max. change	20 K/h
Storage temperature class	1K4
Climatic suitability	
In accordance with the standard	DIN EN 60721-3-3
Humidity	85 % r.h.
Relative humidity class	1K3
Condensation during operation	Not permitted
Max. operating height above sea level	1000 m
Max. operating height with power derating	1000 - 2500 m above sea level
Power derating	1,5 %/100 m
EMC	EN 61800-3

Environmental data	
Vibration	
In accordance with the standard	EN 60721-3-3
Class	3M1
Cooling	
	Fans installed
Noise emission	
	65 dB (A)
Airgap creepage	
Pollution degree	2
Protection type	
In accordance with the standard	EN 60529
Mounting area (e.g. control cabinet)	IP54
Housing	IP20
Terminals	IP20
Mechanical data	
Mounting position	
	vertical
Material	
Housing	Galvanised steel
Dimensions	
Height	345 mm
Height incl. connector	379 mm
Width	70 mm
Depth	243 mm
Depth incl. connector (accessories)	285 mm
Weight	
	4.400 g

Where standards are undated, the 2013-08 latest editions shall apply.

17 Technical details PMCprotego D.12 P/480V

General	
Approvals	CE, EAC (Eurasian), TÜV, UL Listed
Electrical data	
Supply voltage	
Voltage	208 - 480 V
Voltage	3 x 208...3 x 480 V
Kind	AC
Kind	AC
Voltage tolerance	-10 %/+10 %
Frequency range AC	50 - 60 Hz
Supply voltage for	Supply
Voltage	24 V
Kind	DC
Tolerance	
With brake	+15 %
Without brake	+15 %
Max. current consumption	
With brake	3 A
Without brake	1 A
Current range, brake	0,15 - 2 A
Power element	
Power consumption at S1 operation	9 kVA
Max. switch-on frequency	30/h
Continuous output current at 3 x 208 VAC	12 A
Continuous output current at 3 x 230 VAC	12 A
Continuous output current at 3 x 400 VAC	12 A
Continuous output current at 3 x 480 VAC	12 A
Peak output current for 2 s	30 A
Peak output current for 5 s	24 A
Tolerance	-3 %/+3 %
Min. winding inductance of the motor	
at 3 x 208 V AC	1,2 mH
at 3 x 230 V AC	1,3 mH
at 3 x 400 V AC	2,2 mH
at 3 x 480 V AC	2,7 mH
Voltage rise with open terminals	
at 3 x 208 V AC	3 kV/μs
at 3 x 230 V AC	3,3 kV/μs
at 3 x 400 V AC	5,7 kV/μs
at 3 x 480 V AC	6,9 kV/μs

Power element	
Clock frequency of inverted rectifier	
In normal mode	8 kHz
With current reduced to 50 %	16 kHz
Form factor of continuous output current at min. winding inductance	1,01
Rated intermediate circuit voltage	260 - 900 V
Max. rated intermediate circuit voltage	900 V DC
Power dissipation at max. mains voltage	
Without brake	160 W
With inverted rectifier switched off	20 W
Brake chopper power element	
Switch-on threshold	
at 230 V	400 V
at 400 V	720 V
at 480 V	840 V
Max. overvoltage, intermediate circuit	
at 230 V	455 V
at 400 V	800 V
at 480 V	900 V
Pulse brake power	
at 230 V	4 kW
at 400 V	15 kW
at 480 V	21 kW
Internal brake resistor RBi	33 Ohm
Continuous output RBi	100 W
External brake resistor Rbe	33 Ohm
Continuous output RBe	1,5 kW
STO-ENABLE	
Number	2
Input voltage	20 - 30 V
Input current at signal level "1"	33 - 40 mA
Reaction time STO1-ENABLE	2 ms
Reaction time STO2-ENABLE	1 ms
Resolver input	
Number	1
Connection type	9-pin D-Sub female connector
SinCos encoder input, incremental encoder	
Number	1
Connection type	15-pin D-Sub female connector
Analogue inputs	
Number of analogue inputs	2
Type of analogue inputs	Voltage
Input area	-10 ... 10 V
Resolution	16 Bit

Analogue inputs	
Max. common mode voltage	-10 - 10 V
Input resistance	150 kOhm
Scan rate	16 kHz
Inputs	
Number	4 - 6
Scan rate DIGITAL-IN-1 and 2	500 kHz
Scan rate DIGITAL-IN 3 and 4	4 kHz
Signal level at "0"	-3 - +5 V DC
Signal level at "1"	15 - 30 V DC
Input current at signal level "0"	1 mA
Input current at signal level "1"	2 - 15 mA
Input voltage in accordance with EN 61131-2 Type 1	24 V DC
Potential isolation between input and internal module bus voltage	yes
Semiconductor outputs (standard)	
Number	2
Switching capability	
Current	0,1 A
Galvanic isolation	yes
Relay outputs	
Operational readiness function	
Number	1
Max. voltage AC	42 V
Max. voltage DC	30 V
Max. current	500 mA
CANopen interface	
Number	1
Connection type	9-pin D-Sub male connector
Ethernet interface	
Connection type	RJ45
Serial interface	
Number of RS232 interfaces	1
Communication interfaces	
RS232 and CANopen, on the same connector	
Connection type	9-pin D-Sub male connector
Environmental data	
Ambient temperature	
In accordance with the standard	DIN EN 60721-3-3
Temperature range	0 - 40 °C
Temperature range with power derating	40 - 55 °C
Power derating	2,5 %/K

Environmental data	
Storage temperature	
In accordance with the standard	DIN EN 60721-3-1
Temperature range	-25 - 55 °C
Max. change	20 K/h
Storage temperature class	1K4
Climatic suitability	
In accordance with the standard	DIN EN 60721-3-3
Humidity	85 % r.h.
Relative humidity class	1K3
Condensation during operation	Not permitted
EMC	EN 61800-3
Vibration	
In accordance with the standard	EN 60721-3-3
Class	3M1
Cooling	Fans installed
Noise emission	65 dB (A)
Max. operating height above sea level	1000 m
Max. operating height with power derating	1000 - 2500 m above sea level
Power derating	1,5 %/100 m
Airgap creepage	
Pollution degree	2
Protection type	
In accordance with the standard	EN 60529
Mounting area (e.g. control cabinet)	IP54
Housing	IP20
Terminals	IP20
Mechanical data	
Mounting position	vertical
Material	
Housing	Galvanised steel
Dimensions	
Height	345 mm
Height incl. connector	379 mm
Width	70 mm
Depth	243 mm
Depth incl. connector (accessories)	285 mm
Weight	4.400 g

Where standards are undated, the 2013-08 latest editions shall apply.

18 Technical details PMCprotego D.24/230 V

General	
Approvals	CE, EAC (Eurasian), TÜV
Electrical data	
Supply voltage	
Voltage	110 - 230 V
Voltage	1 x 110...3 x 230 V
Kind	AC
Kind	AC
Voltage tolerance	-10 %/+10 %
Frequency range AC	50 - 60 Hz
Supply voltage for	Supply
Voltage	24 V
Kind	DC
Tolerance	
With brake	+15 %
Without brake	+15 %
Max. current consumption	
With brake	3 A
Without brake	1 A
Current range, brake	0,15 - 2 A
Power element	
Power consumption at S1 operation	9 kVA
Max. switch-on frequency	30/h
Continuous output current at 1 x 110 VAC	10 A
Continuous output current at 1 x 230 VAC	11 A
Continuous output current at 3 x 110 VAC	24 A
Continuous output current at 3 x 230 VAC	24 A
Peak output current for 2 s	48 A
Peak output current for 5 s	48 A
Tolerance	-3 %/+3 %
Min. winding inductance of the motor	
at 3 x 230 V AC	0,75 mH
Voltage rise with open terminals	
at 3 x 230 V AC	3,3 kV/μs
Clock frequency of inverted rectifier	
In normal mode	8 kHz
With current reduced to 50 %	16 kHz
Form factor of continuous output current at min. winding inductance	1,01
Rated intermediate circuit voltage	135 - 450 V
Max. rated intermediate circuit voltage	450 V DC

Power element	
Power dissipation at max. mains voltage	
Without brake	175 W
With inverted rectifier switched off	25 W
Brake chopper power element	
Switch-on threshold	
at 230 V	400 V
Max. overvoltage, intermediate circuit	
at 230 V	455 V
Pulse brake power	
at 230 V	6 kW
Internal brake resistor RBi	23 Ohm
Continuous output RBi	200 W
External brake resistor Rbe	23 Ohm
Continuous output RBe	4 kW
STO-ENABLE	
Number	2
Input voltage	20 - 30 V
Input current at signal level "1"	33 - 40 mA
Reaction time STO1-ENABLE	2 ms
Reaction time STO2-ENABLE	1 ms
Resolver input	
Number	1
Connection type	9-pin D-Sub female connector
SinCos encoder input, incremental encoder	
Number	1
Connection type	15-pin D-Sub female connector
Analogue inputs	
Number of analogue inputs	2
Type of analogue inputs	Voltage
Input area	-10 ... 10 V
Resolution	16 Bit
Max. common mode voltage	-10 - 10 V
Input resistance	150 kOhm
Scan rate	16 kHz
Inputs	
Number	4 - 6
Scan rate DIGITAL-IN-1 and 2	500 kHz
Scan rate DIGITAL-IN 3 and 4	4 kHz
Signal level at "0"	-3 - +5 V DC
Signal level at "1"	15 - 30 V DC
Input current at signal level "0"	1 mA
Input current at signal level "1"	2 - 15 mA
Input voltage in accordance with EN 61131-2 Type 1	24 V DC

Inputs	
Potential isolation between input and internal module bus voltage	yes
Semiconductor outputs (standard)	
Number	2
Switching capability	
Current	0,1 A
Relay outputs	
Operational readiness function	
Number	1
Max. voltage AC	42 V
Max. voltage DC	30 V
Max. current	500 mA
CANopen interface	
Number	1
Connection type	9-pin D-Sub male connector
Ethernet interface	
Connection type	RJ45
Serial interface	
Number of RS232 interfaces	1
Communication interfaces	
RS232 and CANopen, on the same connector	
Connection type	9-pin D-Sub male connector
Environmental data	
Ambient temperature	
In accordance with the standard	DIN EN 60721-3-3
Temperature range	0 - 40 °C
Temperature range with power derating	40 - 55 °C
Power derating	2,5 %/K
Storage temperature	
In accordance with the standard	DIN EN 60721-3-1
Temperature range	-25 - 55 °C
Max. change	20 K/h
Storage temperature class	1K4
Climatic suitability	
In accordance with the standard	DIN EN 60721-3-3
Humidity	85 % r.h.
Relative humidity class	1K3
Condensation during operation	Not permitted
Max. operating height above sea level	1000 m
Max. operating height with power derating	1000 - 2500 m above sea level
Power derating	1,5 %/100 m
EMC	EN 61800-3

Environmental data	
Vibration	
In accordance with the standard	EN 60721-3-3
Class	3M1
Cooling	Fans installed
Noise emission	65 dB (A)
Airgap creepage	
Pollution degree	2
Protection type	
In accordance with the standard	EN 60529
Mounting area (e.g. control cabinet)	IP54
Housing	IP20
Terminals	IP20
Mechanical data	
Mounting position	vertical
Material	
Housing	Galvanised steel
Dimensions	
Height	348 mm
Height incl. connector	382 mm
Width	100 mm
Depth	243 mm
Depth incl. connector (accessories)	285 mm
Weight	5.500 g

Where standards are undated, the 2013-08 latest editions shall apply.

19 Technical details PMCprotego D.24/480V

General	
Approvals	CE, EAC (Eurasian), TÜV, UL Listed
Electrical data	
Supply voltage	
Voltage	208 - 480 V
Voltage	3 x 208...3 x 480 V
Kind	AC
Kind	AC
Voltage tolerance	-10 %/+10 %
Frequency range AC	50 - 60 Hz
Supply voltage for	Supply
Voltage	24 V
Kind	DC
Tolerance	
With brake	+15 %
Without brake	+15 %
Max. current consumption	
With brake	3 A
Without brake	1 A
Current range, brake	0,15 - 2 A
Power element	
Power consumption at S1 operation	18 kVA
Max. switch-on frequency	30/h
Continuous output current at 3 x 208 VAC	24 A
Continuous output current at 3 x 230 VAC	24 A
Continuous output current at 3 x 400 VAC	24 A
Continuous output current at 3 x 480 VAC	24 A
Peak output current for 2 s	48 A
Peak output current for 5 s	48 A
Tolerance	-3 %/+3 %
Min. winding inductance of the motor	
at 3 x 208 V AC	0,7 mH
at 3 x 230 V AC	0,8 mH
at 3 x 400 V AC	1,4 mH
at 3 x 480 V AC	1,7 mH
Voltage rise with open terminals	
at 3 x 208 V AC	3 kV/μs
at 3 x 230 V AC	3,3 kV/μs
at 3 x 400 V AC	5,7 kV/μs
at 3 x 480 V AC	6,9 kV/μs

Power element	
Clock frequency of inverted rectifier	
In normal mode	8 kHz
With current reduced to 50 %	16 kHz
Form factor of continuous output current at min. winding inductance	1,01
Rated intermediate circuit voltage	260 - 900 V
Max. rated intermediate circuit voltage	900 V DC
Power dissipation at max. mains voltage	
Without brake	330 W
With inverted rectifier switched off	25 W
Brake chopper power element	
Switch-on threshold	
at 230 V	400 V
at 400 V	720 V
at 480 V	840 V
Max. overvoltage, intermediate circuit	
at 230 V	455 V
at 400 V	800 V
at 480 V	900 V
Pulse brake power	
at 230 V	6 kW
at 400 V	23 kW
at 480 V	30 kW
Internal brake resistor RBi	23 Ohm
Continuous output RBi	200 W
External brake resistor Rbe	23 Ohm
Continuous output RBe	4 kW
STO-ENABLE	
Number	2
Input voltage	20 - 30 V
Input current at signal level "1"	33 - 40 mA
Reaction time STO1-ENABLE	2 ms
Reaction time STO2-ENABLE	1 ms
Resolver input	
Number	1
Connection type	9-pin D-Sub female connector
SinCos encoder input, incremental encoder	
Number	1
Connection type	15-pin D-Sub female connector
Analogue inputs	
Number of analogue inputs	2
Type of analogue inputs	Voltage
Input area	-10 ... 10 V
Resolution	16 Bit

Analogue inputs	
Max. common mode voltage	-10 - 10 V
Input resistance	150 kOhm
Scan rate	16 kHz
Inputs	
Number	4 - 6
Scan rate DIGITAL-IN-1 and 2	500 kHz
Scan rate DIGITAL-IN 3 and 4	4 kHz
Signal level at "0"	-3 - +5 V DC
Signal level at "1"	15 - 30 V DC
Input current at signal level "0"	1 mA
Input current at signal level "1"	2 - 15 mA
Input voltage in accordance with EN 61131-2 Type 1	24 V DC
Potential isolation between input and internal module bus voltage	yes
Semiconductor outputs (standard)	
Number	2
Switching capability	
Current	0,1 A
Galvanic isolation	yes
Relay outputs	
Operational readiness function	
Number	1
Max. voltage AC	42 V
Max. voltage DC	30 V
Max. current	500 mA
CANopen interface	
Number	1
Connection type	9-pin D-Sub male connector
Ethernet interface	
Connection type	RJ45
Serial interface	
Number of RS232 interfaces	1
Communication interfaces	
RS232 and CANopen, on the same connector	
Connection type	9-pin D-Sub male connector
Environmental data	
Ambient temperature	
In accordance with the standard	DIN EN 60721-3-3
Temperature range	0 - 40 °C
Temperature range with power derating	40 - 55 °C
Power derating	2,5 %/K

Environmental data	
Storage temperature	
In accordance with the standard	DIN EN 60721-3-1
Temperature range	-25 - 55 °C
Max. change	20 K/h
Storage temperature class	1K4
Climatic suitability	
In accordance with the standard	DIN EN 60721-3-3
Humidity	85 % r.h.
Relative humidity class	1K3
Condensation during operation	Not permitted
EMC	EN 61800-3
Vibration	
In accordance with the standard	EN 60721-3-3
Class	3M1
Cooling	Fans installed
Noise emission	65 dB (A)
Max. operating height above sea level	1000 m
Max. operating height with power derating	1000 - 2500 m above sea level
Power derating	1,5 %/100 m
Airgap creepage	
Pollution degree	2
Protection type	
In accordance with the standard	EN 60529
Mounting area (e.g. control cabinet)	IP54
Housing	IP20
Terminals	IP20
Mechanical data	
Mounting position	vertical
Material	
Housing	Galvanised steel
Dimensions	
Height	348 mm
Height incl. connector	382 mm
Width	100 mm
Depth	243 mm
Depth incl. connector (accessories)	285 mm
Weight	5.500 g

Where standards are undated, the 2013-08 latest editions shall apply.

20 Technical details PMCprotego D.24 P/230 V

General	
Approvals	CE, EAC (Eurasian), TÜV
Electrical data	
Supply voltage	
Voltage	110 - 230 V
Voltage	1 x 110...3 x 230 V
Kind	AC
Kind	AC
Voltage tolerance	-10 %/+10 %
Frequency range AC	50 - 60 Hz
Supply voltage for	Supply
Voltage	24 V
Kind	DC
Tolerance	
With brake	+15 %
Without brake	+15 %
Max. current consumption	
With brake	3 A
Without brake	1 A
Current range, brake	0,15 - 2 A
Power element	
Power consumption at S1 operation	9 kVA
Max. switch-on frequency	30/h
Continuous output current at 1 x 110 VAC	10 A
Continuous output current at 1 x 230 VAC	11 A
Continuous output current at 3 x 110 VAC	24 A
Continuous output current at 3 x 230 VAC	24 A
Peak output current for 2 s	72 A
Peak output current for 5 s	48 A
Tolerance	-3 %/+3 %
Min. winding inductance of the motor	
at 3 x 230 V AC	0,5 mH
Voltage rise with open terminals	
at 3 x 230 V AC	3,3 kV/μs
Clock frequency of inverted rectifier	
In normal mode	8 kHz
With current reduced to 50 %	16 kHz
Form factor of continuous output current at min. winding inductance	1,01
Rated intermediate circuit voltage	135 - 450 V
Max. rated intermediate circuit voltage	450 V DC

Power element	
Power dissipation at max. mains voltage	
Without brake	175 W
With inverted rectifier switched off	25 W
Brake chopper power element	
Switch-on threshold	
at 230 V	400 V
Max. overvoltage, intermediate circuit	
at 230 V	455 V
Pulse brake power	
at 230 V	6 kW
Internal brake resistor RBi	23 Ohm
Continuous output RBi	200 W
External brake resistor Rbe	23 Ohm
Continuous output RBe	4 kW
STO-ENABLE	
Number	2
Input voltage	20 - 30 V
Input current at signal level "1"	33 - 40 mA
Reaction time STO1-ENABLE	2 ms
Reaction time STO2-ENABLE	1 ms
Resolver input	
Number	1
Connection type	9-pin D-Sub female connector
SinCos encoder input, incremental encoder	
Number	1
Connection type	15-pin D-Sub female connector
Analogue inputs	
Number of analogue inputs	2
Type of analogue inputs	Voltage
Input area	-10 ... 10 V
Resolution	16 Bit
Max. common mode voltage	-10 - 10 V
Input resistance	150 kOhm
Scan rate	16 kHz
Inputs	
Number	4 - 6
Scan rate DIGITAL-IN-1 and 2	500 kHz
Scan rate DIGITAL-IN 3 and 4	4 kHz
Signal level at "0"	-3 - +5 V DC
Signal level at "1"	15 - 30 V DC
Input current at signal level "0"	1 mA
Input current at signal level "1"	2 - 15 mA
Input voltage in accordance with EN 61131-2 Type 1	24 V DC

Inputs	
Potential isolation between input and internal module bus voltage	yes
Semiconductor outputs (standard)	
Number	2
Switching capability	
Current	0,1 A
Relay outputs	
Operational readiness function	
Number	1
Max. voltage AC	42 V
Max. voltage DC	30 V
Max. current	500 mA
CANopen interface	
Number	1
Connection type	9-pin D-Sub male connector
Ethernet interface	
Connection type	RJ45
Serial interface	
Number of RS232 interfaces	1
Communication interfaces	
RS232 and CANopen, on the same connector	
Connection type	9-pin D-Sub male connector
Environmental data	
Ambient temperature	
In accordance with the standard	DIN EN 60721-3-3
Temperature range	0 - 40 °C
Temperature range with power derating	40 - 55 °C
Power derating	2,5 %/K
Storage temperature	
In accordance with the standard	DIN EN 60721-3-1
Temperature range	-25 - 55 °C
Max. change	20 K/h
Storage temperature class	1K4
Climatic suitability	
In accordance with the standard	DIN EN 60721-3-3
Humidity	85 % r.h.
Relative humidity class	1K3
Condensation during operation	Not permitted
Max. operating height above sea level	1000 m
Max. operating height with power derating	1000 - 2500 m above sea level
Power derating	1,5 %/100 m
EMC	EN 61800-3

Environmental data	
Vibration	
In accordance with the standard	EN 60721-3-3
Class	3M1
Cooling	Fans installed
Noise emission	65 dB (A)
Airgap creepage	
Pollution degree	2
Protection type	
In accordance with the standard	EN 60529
Mounting area (e.g. control cabinet)	IP54
Housing	IP20
Terminals	IP20
Mechanical data	
Mounting position	vertical
Material	
Housing	Galvanised steel
Dimensions	
Height	348 mm
Height incl. connector	382 mm
Width	100 mm
Depth	243 mm
Depth incl. connector (accessories)	285 mm
Weight	5.500 g

Where standards are undated, the 2013-08 latest editions shall apply.

21 Technical details PMCprotego D.24 P/480V

General	
Approvals	CE, EAC (Eurasian), TÜV, UL Listed
Electrical data	
Supply voltage	
Voltage	208 - 480 V
Voltage	3 x 208...3 x 480 V
Kind	AC
Kind	AC
Voltage tolerance	-10 %/+10 %
Frequency range AC	50 - 60 Hz
Supply voltage for	Supply
Voltage	24 V
Kind	DC
Tolerance	
With brake	+15 %
Without brake	+15 %
Max. current consumption	
With brake	3 A
Without brake	1 A
Current range, brake	0,15 - 2 A
Power element	
Power consumption at S1 operation	18 kVA
Max. switch-on frequency	30/h
Continuous output current at 3 x 208 VAC	24 A
Continuous output current at 3 x 230 VAC	24 A
Continuous output current at 3 x 400 VAC	24 A
Continuous output current at 3 x 480 VAC	24 A
Peak output current for 2 s	72 A
Peak output current for 5 s	48 A
Tolerance	-3 %/+3 %
Min. winding inductance of the motor	
at 3 x 208 V AC	0,7 mH
at 3 x 230 V AC	0,8 mH
at 3 x 400 V AC	1,4 mH
at 3 x 480 V AC	1,7 mH
Voltage rise with open terminals	
at 3 x 208 V AC	3 kV/μs
at 3 x 230 V AC	3,3 kV/μs
at 3 x 400 V AC	5,7 kV/μs
at 3 x 480 V AC	6,9 kV/μs

Power element	
Clock frequency of inverted rectifier	
In normal mode	8 kHz
With current reduced to 50 %	16 kHz
Form factor of continuous output current at min. winding inductance	1,01
Rated intermediate circuit voltage	260 - 900 V
Max. rated intermediate circuit voltage	900 V DC
Power dissipation at max. mains voltage	
Without brake	330 W
With inverted rectifier switched off	25 W
Brake chopper power element	
Switch-on threshold	
at 230 V	400 V
at 400 V	720 V
at 480 V	840 V
Max. overvoltage, intermediate circuit	
at 230 V	455 V
at 400 V	800 V
at 480 V	900 V
Pulse brake power	
at 230 V	6 kW
at 400 V	23 kW
at 480 V	30 kW
Internal brake resistor RBi	23 Ohm
Continuous output RBi	200 W
External brake resistor Rbe	23 Ohm
Continuous output RBe	4 kW
STO-ENABLE	
Number	2
Input voltage	20 - 30 V
Input current at signal level "1"	33 - 40 mA
Reaction time STO1-ENABLE	2 ms
Reaction time STO2-ENABLE	1 ms
Resolver input	
Number	1
Connection type	9-pin D-Sub female connector
SinCos encoder input, incremental encoder	
Number	1
Connection type	15-pin D-Sub female connector
Analogue inputs	
Number of analogue inputs	2
Type of analogue inputs	Voltage
Input area	-10 ... 10 V
Resolution	16 Bit

Analogue inputs	
Max. common mode voltage	-10 - 10 V
Input resistance	150 kOhm
Scan rate	16 kHz
Inputs	
Number	4 - 6
Scan rate DIGITAL-IN-1 and 2	500 kHz
Scan rate DIGITAL-IN 3 and 4	4 kHz
Signal level at "0"	-3 - +5 V DC
Signal level at "1"	15 - 30 V DC
Input current at signal level "0"	1 mA
Input current at signal level "1"	2 - 15 mA
Input voltage in accordance with EN 61131-2 Type 1	24 V DC
Potential isolation between input and internal module bus voltage	yes
Semiconductor outputs (standard)	
Number	2
Switching capability	
Current	0,1 A
Galvanic isolation	yes
Relay outputs	
Operational readiness function	
Number	1
Max. voltage AC	42 V
Max. voltage DC	30 V
Max. current	500 mA
CANopen interface	
Number	1
Connection type	9-pin D-Sub male connector
Ethernet interface	
Connection type	RJ45
Serial interface	
Number of RS232 interfaces	1
Communication interfaces	
RS232 and CANopen, on the same connector	
Connection type	9-pin D-Sub male connector
Environmental data	
Ambient temperature	
In accordance with the standard	DIN EN 60721-3-3
Temperature range	0 - 40 °C
Temperature range with power derating	40 - 55 °C
Power derating	2,5 %/K

Environmental data	
Storage temperature	
In accordance with the standard	DIN EN 60721-3-1
Temperature range	-25 - 55 °C
Max. change	20 K/h
Storage temperature class	1K4
Climatic suitability	
In accordance with the standard	DIN EN 60721-3-3
Humidity	85 % r.h.
Relative humidity class	1K3
Condensation during operation	Not permitted
EMC	EN 61800-3
Vibration	
In accordance with the standard	EN 60721-3-3
Class	3M1
Cooling	Fans installed
Noise emission	65 dB (A)
Max. operating height above sea level	1000 m
Max. operating height with power derating	1000 - 2500 m above sea level
Power derating	1,5 %/100 m
Airgap creepage	
Pollution degree	2
Protection type	
In accordance with the standard	EN 60529
Mounting area (e.g. control cabinet)	IP54
Housing	IP20
Terminals	IP20
Mechanical data	
Mounting position	vertical
Material	
Housing	Galvanised steel
Dimensions	
Height	348 mm
Height incl. connector	382 mm
Width	100 mm
Depth	243 mm
Depth incl. connector (accessories)	285 mm
Weight	5.500 g

Where standards are undated, the 2013-08 latest editions shall apply.

22 Safety characteristic data



NOTICE

You must comply with the safety characteristic data in order to achieve the required safety level for your plant/machine.

Operating mode	EN ISO 13849-1: 2015 PL	EN ISO 13849-1: 2015 Category	EN 62061 SIL CL	EN 62061 PFH _D [1/h]	IEC 61511 SIL	IEC 61511 PFD	EN ISO 13849-1: 2015 T _M [year]
STO 1/2, 2-ch. with feedback loop	PL e	Cat. 4	SIL CL 3	1,04E-09	SIL 3	1,81E-06	20
STO1, 1-ch. without feedback loop	PL d	Cat. 2	SIL CL 2	7,05E-08	SIL 2	6,09E-03	20

All the units used within a safety function must be considered when calculating the safety characteristic data.



INFORMATION

A safety function's SIL/PL values are **not** identical to the SIL/PL values of the units that are used and may be different. We recommend that you use the PAScal software tool to calculate the safety function's SIL/PL values.

23 Order reference

23.1 Order reference for device

Only the basic versions are listed. Please refer to the [Type code \[17\]](#) for expansion details.

Product type	Features	Order No.
PMCprotego D.01/480V	Servo amplifier continuous output current 1.5 A, 480 V	8 176 100
PMCprotego D.03/480V	Servo amplifier continuous output current 3 A, 480 V	8 176 101
PMCprotego D.06/480V	Servo amplifier continuous output current 6 A, 480 V	8 176 102
PMCprotego D.12/480V	Servo amplifier continuous output current 12 A, 480 V	8 176 103
PMCprotego D.12 P/480V	Servo amplifier continuous output current 12 A, increased peak output current, 480 V	8 176 423
PMCprotego D.24/480V	Servo amplifier continuous output current 24 A, 480 V	8 176 104
PMCprotego D.24 P/480V	Servo amplifier continuous output current 24 A, increased peak output current, 480 V	8 176 424
PMCprotego D.01/230V	Servo amplifier continuous output current 1.5 A, 230 V	8 176 811
PMCprotego D.03/230V	Servo amplifier continuous output current 3 A, 230 V	8 176 812
PMCprotego D.06/230V	Servo amplifier continuous output current 6 A, 230 V	8 176 813
PMCprotego D.12/230V	Servo amplifier continuous output current 12 A, 230 V	8 176 814
PMCprotego D.12 P/230V	Servo amplifier continuous output current 12 A, increased peak output current, 230 V	8 176 815
PMCprotego D.24/230V	Servo amplifier continuous output current 24 A, 230 V	8 176 816
PMCprotego D.24 P/230V	Servo amplifier continuous output current 24 A, increased peak output current, 230 V	8 176 817

23.2 Order reference for accessories

23.2.1 Safety cards to retrofit or as spare part

Product type	Features	Order No.
PMCPROTEGO S1-2	Safety Card SIL CL 3 of EN/IEC 62061	680 004
PMCPROTEGO S2-2	Safety Card SIL CL 2 of EN/IEC 62061	680 006
PMCPROTEGO S1-2-C	Coated safety card SIL CL 3 of EN/IEC 62061	680 008
PMCPROTEGO S2-2-C	Coated safety card SIL CL 2 of EN/IEC 62061	680 009
PMCPROTEGO S SPARE CONNECTOR X30	Spare connector for interface X30	8 176 680

23.2.2 Expansion cards to retrofit or as spare part

Product type	Features	Order no.
PMC PROFINET EXPANSION CARD	Expansion card for PROFINET	680 150
PMC EXPANSION CARD POSI/O-AIO	Expansion card for POSI/O-AIO	8 176 108
PMC EXPANSION CARD D1 (I/O expansion)	Expansion card for D1 (I/O expansion)	4 105 531
PMC EXPANSION CARD POSI/O	Expansion card for POSI/O	8 176 278
PMC EXPANSION CARD PROFIBUS DP SLAVE	Expansion card for PROFIBUS DP SLAVE	8 176 280

23.2.3 Interface cable, interface adapter, SD card

Product type	Features	Order no.
Cable interface PC RS232-DD4/primo Drive	Interface cable	1 802 949
PSS Conv USB / RS232	Interface adapter USB /RS 232	305 160
SD Memory Card 512MB	SD card 512 MByte	313 100

23.2.4 Connector for cable assembly, motor power cable

Product type	Features	Order No.
PMC PROTEGO MOTOR CONNECTOR SET	Motor connector set	8 176 330

23.2.5 Connector set as spare part

Product type	Features	Order No.
PMC PROTEGOD 01-24 SPARE CONNECTOR SET	Spare connector set consisting of: Connectors X3A, X3B, X4B, X0, X8	8 176 674

23.2.6 Y connector

Product type	Features	Order no.
PMCprotego D connector X0Y	Y connector	8 176 347
PMCprotego D connector set X8Y + X4A	Y connector	8 176 348

23.2.7 Energy store

Product type	Features	Order no.
PMCenergy SD.B2	Energy store	8 176 860
PMCenergy SD.E1	Expansion module (Increases the energy store)	8 176 862

23.2.8 Connection cable to the motor series "PM Ctendo SZ"

The connection cables from the servo amplifier to the motor series "PM Ctendo SZ" can be found in the catalogue or they are available on request.

24 Appendix

24.1 Abbreviations

Abbreviation	Description
AGND	Earth, analogue input
BTB/RTO	Ready for operation
CAN	Fieldbus (CANopen)
CE	Communauté Européenne
CLK Clock	Pulse signal
COM	Serial interface on a personal computer
DGND	Earth (24 V and digital I/O)
EEPROM	Electrically erasable programmable read-only memory
EMI	Electromagnetic interference
EMC	Electromagnetic compatibility
ESD	Electrostatic discharge
F-SMA	Fibre-optic cable connector in accordance with IEC 60874-2
IGBT	Insulated gate bipolar transistor
INC	Incremental interface
LED	Light-emitting diode
MByte	Megabyte
NI	Zero pulse
PELV	Protective extra low voltage
PWM	Pulse width modulation
RAM	Volatile memory
$R_{\text{Brake}} / R_{\text{B}}$	Brake resistor
RBext	External brake resistor
RBint	Internal brake resistor
RES	Resolver
ROD	"A quad B" encoder, incremental encoder
S1	Continuous duty
S3	Intermittent duty
SBT	Safe brake test
SDI	Safe direction
SLS	Safely limited speed
SOS	Safe operational stop
PLC	Programmable logic controller
SRAM	Static RAM

Abbreviation	Description
SS1	Safe stop
SS2	Safe operating stop
SSI	Synchronous serial interface
SSR	Safe speed range
STO	Safety function STO
VAC	AC voltage
VDC	DC voltage

Absolute encoder

Encoder that provides an absolute value for each position. The absolute value corresponds directly to the position of the detected machine component.

Brake resistor

Resistor that converts electrical energy into thermal energy, generated when a motor is braked

Electromagnetic compatibility (EMC)

System's properties with regard to noise emission and noise immunity

Emergency stop

EN 60204-01, Annex E: "Emergency stop; an emergency operation intended to stop a process or a movement that has become hazardous."

Emergency switching off

EN 60204-1, Annex E: "Emergency switching off; an emergency operation intended to switch off the supply of electrical energy to all or a part of an installation where a risk of electric shock or another risk of electrical origin is involved."

Encoder

Encoder to detect angle changes (rotational movement)

Encoder

Incremental encoder or absolute encoder, which detects the current position of a motor shaft or drive unit and converts it into an electrical signal

EtherNet/IP

Open industrial standard, which expands the classic Ethernet with an industrial protocol; this standard was drawn up jointly by ControlNet International (CI) and the Open DeviceNet Vendor Association (ODVA), with help from the Industrial Ethernet Association (IEA).

Gray code

Display format of binary figures, in which adjacent figures differ in only one single bit

Holding brake

The holding brake holds moved masses or loads at standstill, after the movement has been braked.

Incremental encoder

Sensor for detecting linear or rotational positional changes; path, speed and direction can be determined by evaluating the number of pulses, pulse frequency and phase position.

Intermediate circuit

Circuit to smooth the still undulating, rectified supply voltage to the servo amplifier; also used as an energy store (with feedback for example).

Intermediate circuit voltage

Voltage at a circuit on rectifier circuits

Inverted rectifier

Output stage of the power element of a servo amplifier or frequency converter. A sinusoidal output voltage is generated as an average value through pulse width modulation (PWM) of the DC voltage on the intermediate circuit.

Motion block

Data package containing all the position control parameters required for a motion task

Motion control

Motion management for a large number of physically separate drive axes within a plant or application

Motion controller

Characterises the function of executing movements by speed, angle synchronisation and position or also interdependently via closed control loops, in accordance with specified concepts.

Network configuration

Distinction of the supply voltage with regard to the different earthing methods TN, TT and IT (see IEC 60364)

Power element

Converts the fixed voltage and frequency of the mains into a variable voltage and frequency for driving an electric motor. This means that the rotational speed and torque are infinitely variable. The power element consists of a rectifier, intermediate circuit and inverted rectifier (output stage).

Pulse width modulation (PWM)

Procedure for generating a three-phase, sinusoidal voltage from a DC voltage. Periodically switching an identical magnitude on and off creates an output magnitude of any desired frequency and amplitude, based on the duty cycle.

Resolver

Encoder that converts the angular position of a rotor into an analogue value

Safe Torque Off (STO)

Stop function in accordance with EN 61800-5-2: "No power that can cause a rotation (or in the case of a linear motor, a movement) is supplied to the motor. The PDS(SR) (electrical power drive system) does not supply any power to the motor that can generate torque (or in the case of a linear motor, force)."

Safety function

Function with a specific safety property, which maintains the safe condition of the plant or prevents hazardous conditions arising on the plant

Servo amplifier

Converter for servo motors, enabling controlled operation of three-phase motors for dynamic movements (closed loop)

Servo technology

Drive technology, in which the individual components are so compatible that the overall system achieves optimum dynamics and precision

Speed regulator

Regulates the difference between the speed setpoint and the actual value to 0, output: current setpoint